



# Sydney Olympic Park

## Urban Elements Design Manual

## Contents

	<b>Revision Status</b>
<b>1.0 Introduction</b>	<b>2009</b>
1.1 Vision	Page 2
1.2 How to Use the UEDM	Page 3
1.3 Companion Documents	Page 5
1.4 Public Domain Principals	Page 7
1.5 Provisions for Major Events	Page 7
1.6 Access Considerations	Page 7
1.7 Structure of the UEDM	Page 7
1.8 Public Domain Procurement	Page 8
1.9 Use of UEDM	Page 8
1.10 Public Domain Plans	Page 8
1.11 Park and Urban Squares Plans	Page 8
1.12 Checklist for Public Domain Approvals	Page 9
<b>2.0 Placement and Co-ordination</b>	<b>2009</b>
2.1 Street Hierarchy and Types	
2.2 Intersection Arrangement	
2.3 Urban Elements Arrangement	
<b>3.0 Urban Elements and Details</b>	<b>2009</b>
3.1 Pavements and Level Changes	
3.2 Street Furniture	
3.3 Lighting	
3.4 Engineering Elements	
3.5 Street Tree Planting	
3.6 Signage	





# Introduction

Urban Elements Design Manual  
Section

# 1.0

ISBN 978-0-9805976-1-5

© All rights reserved. No part of this work will be reproduced, translated, modified, transmitted or stored in any form by any means without the prior permission of Sydney Olympic Park Authority.

At Sydney Olympic Park Authority, we are committed to ensuring that Sydney Olympic Park's public domain is consistently of the highest standard and that it promotes an engaged, healthy environment for our community and visitors.

The challenge of ensuring a high quality public domain will intensify in the years ahead as Sydney Olympic Park maintains its position as Australia's premier sports and events precinct, grows its business and education populations and welcomes a new residential community.

Sydney Olympic Park Authority has developed the Urban Elements Design Manual, which sets out clear quality and performance standards for the public domain. Together with other planning and control documents such as the Master Plan 2030, it will ensure that Sydney Olympic Park continues to be an exemplar of high quality, sustainable urban development.

I commend the Urban Elements Design Manual to all organisations and professionals involved in the continuing development of Sydney Olympic Park.

**Alan Marsh**

Chief Executive Officer  
Sydney Olympic Park Authority

## 1.1 Vision

### Public Domain: Future Vision

Sydney Olympic Park covers a total of 640 hectares and is one of the world’s largest urban parks. It includes 425 hectares of green spaces along with a diverse range of world-class sporting and leisure venues and a new Town Centre. This urban core to the park is evolving and will include commercial, residential, retail and educational developments accommodating a significant local population.

Sydney Olympic Park’s public domain will be used in different and unexpected ways. The urban domain is required to be robust, flexible and of high quality.

The Urban Elements Design Manual (UEDM) sets out the quality and performance standards for the public domain, with an emphasis on the seamless

integration of new urban spaces within the Town Centre with the existing public realm designed to serve major sporting and leisure venues.

Sydney Olympic Park Authority’s vision for the public domain is to be consistently high quality, multi-functional, provide for equitable accessible, be sustainable and to balance the needs of workers, residents, visitors and students, while continuing to be a world-class regional park and premier for major sporting, entertainment and cultural events precinct.

The UEDM should be read in conjunction with other key Sydney Olympic Park Authority planning and design control documents including *the Master Plan 2030* and a range of relevant strategies and guidelines.



## 1.2 How to Use the UEDM

### What are the Objectives of the UEDM?

The purpose of the UEDM is to deliver an integrated and consistently high quality public realm for Sydney Olympic Park with a particular focus on the urban core of the Town Centre.

The UEDM as a technical manual sets standards of performance and design quality which considers robustness, fitness for purpose, sustainability of material selection, operational efficiency and integration with the existing public domain as a legacy of the 2000 Summer Olympics. The UEDM also sets standards for public safety, amenity and universal access.

The UEDM aims to achieve correct placement and coordination of urban elements to:

- Reinforce street hierarchy and special character
- Nominate required paths of travel for pedestrians, cyclists, wheelchairs, prams and the integration with uses such as outdoor eating
- Achieve a seamless integration of elements into the paved ground plane

The Parklands Element Design Manual (PEDM) is a separate companion document that addresses the coordination of all elements relevant to the development of the Parklands of Sydney Olympic Park.

### Who Should use this Document?

The UEDM as a technical reference manual is for use by decision makers both within SOPA and those involved in making informed planning and design decisions for all new developments at Sydney Olympic Park. The UEDM is relevant to the following groups:

- SOPA decision makers
- External decision makers involved with commercial developments throughout various stages of planning, design and construction:
  - Requests for Development Proposal (RFDP)
  - Agreements for Lease (AFL)
  - Development Applications (DA)
  - Construction Certificates (CC)
  - Delivery and Construction

- Planners, Urban Designers, Architects, Landscape Architects, Graphic Designers, Lighting and Civil Engineers and all professionals who contribute to the design of the public domain
- Building and public domain construction contractors

### How Should the UEDM be Used?

The UEDM is designed to be read in conjunction with the Master Plan 2030 and the following range of other relevant SOPA design guidelines and planning documents:

- SOPA Master Plan 2030
- SOPA Guidelines: Commercial Outdoor Seating Policy
- SOPA Guidelines: Access
- SOPA Guidelines: Outdoor Advertising and promotional signage
- SOPA Guidelines: Protection of Trees on Construction Sites
- SOPA Parklands Element Design Manual (PEDM)
- Major Events Impact Guidelines

Companion document relationships are shown in figure 1.1, section 1.3.

## Step by Step Guide for using the UEDM

<p><b>Step 1</b> identify where your site is in the town centre</p>	<p>Firstly identify the location of your development site and then establish the type of street your site has frontage to by referring to the Streets Master Plan. This plan indicates both existing and proposed streets that your site has frontage to and is based on a colour coded street hierarchy comprised of :</p> <ul style="list-style-type: none"> <li>• Civic Streets</li> <li>• Perimeter Avenues</li> <li>• Town Streets</li> <li>• Local Streets</li> <li>• Park Edge Streets</li> </ul>
<p><b>Step 2</b> identify your street type</p>	<p>Secondly, review the typical cross sections provide for each street type. In the top right section of these section pages, the complete palette of public domain elements is listed including pavement finishes, street furniture, lighting, way-finding signage and the species of street tree planting. The elements on these pages when properly coordinated will form the total built character of your public domain area.</p>
<p><b>Step 3</b> identify the arrangement of urban elements for your street</p>	<p>In order to understand critical relationships between the key elements in your public domain, next visit the Placement and Co-ordination section for urban elements. This indicates the critical setout and inter-relationships of key elements within the public domain for:</p> <ul style="list-style-type: none"> <li>• Fully paved footpaths</li> <li>• Pavement and verge footpaths</li> <li>• Footpaths within Parks</li> </ul>
<p><b>Step 4</b> review the specific elements in your street</p>	<p>The next step is to review the requirements for individual public domain elements. These pages provide technical information for the individual elements and nominate performance criteria, materials and detailed design information including dimensions. Where relevant, details for nominated suppliers are also provided.</p> <p>The coloured button references in the bottom right side of the element pages indicate other streets where these elements occur for coordination purposes.</p>
<p><b>Step 5</b> prepare an integrated public domain design plan</p>	<p>All the information provided in the UEDM is for design intent purposes only. At this stage it will be necessary for a qualified designer (Urban designer, Architect or Landscape Architect) to prepare an accurate and scaled plan of the site specific design proposal for the public domain associated with your site. This should consider opportunities such as views, micro-climate issues such as prevailing winds and solar access and constraints such as significant existing trees, underground services and integration with the levels for adjoining public domain areas and buildings.</p>
<p><b>Step 6</b> submit for SOPA approval</p>	<p>It is a requirement that a public domain package of scaled plans and sections be prepared as the basis for ongoing negotiations and approval by SOPA. The public domain package is to be read in conjunction with the civil engineering and architectural drawings. Refer to the checklist at the end of this section.</p>



## 1.3 Companion Documents

Figure 1.1

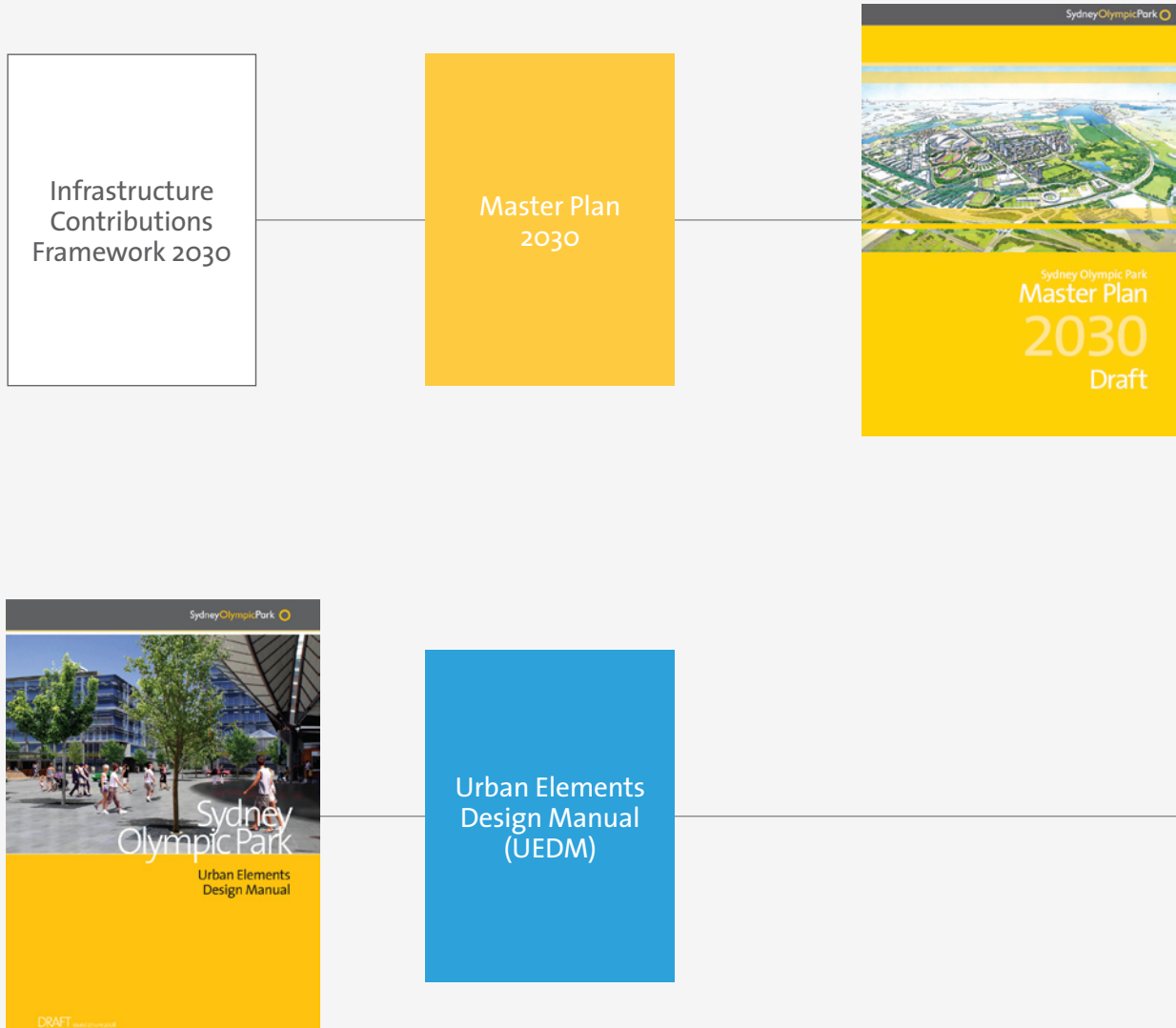

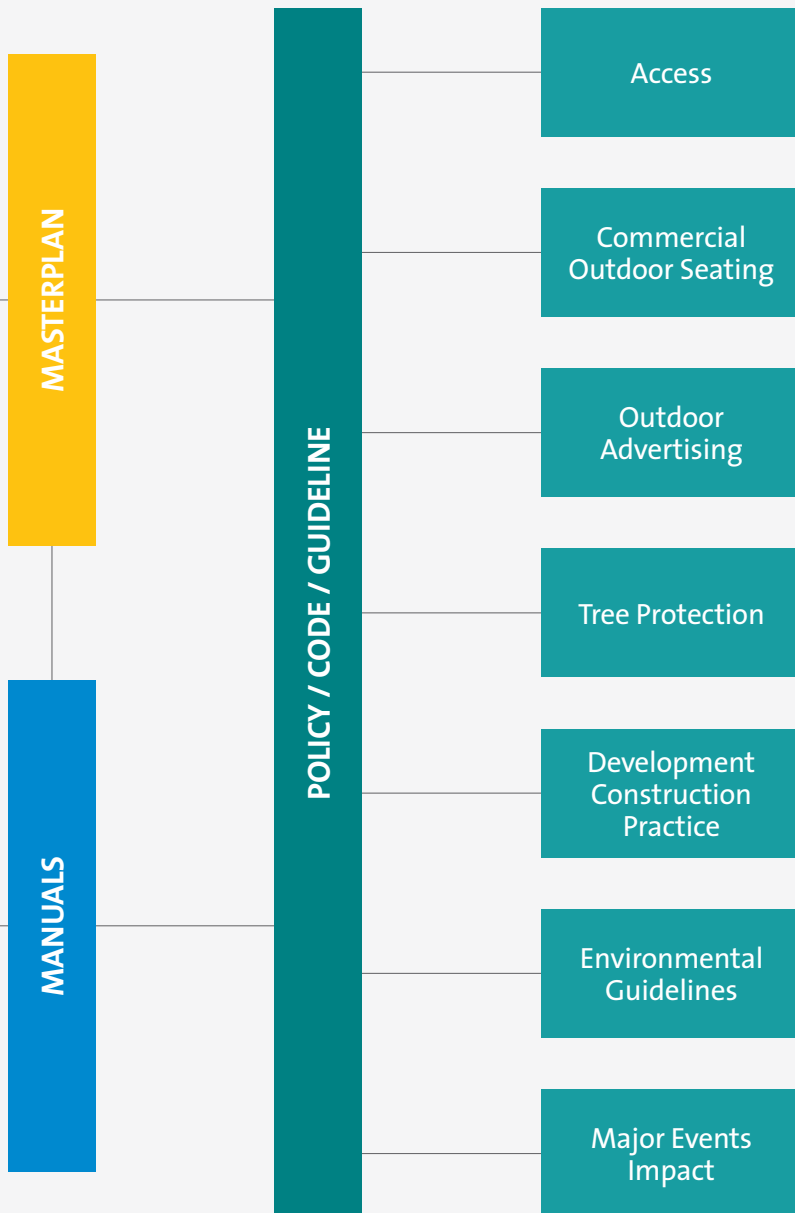

## 1.4 Public Domain Principles

The character of Sydney Olympic Park Public Domain has been built on the following principles.

- A co-ordinated system of public domain elements implemented across the whole site.
- Designs are modern, functional, robust, elegantly detailed and appropriately scaled for the large spaces. A range of new more finely grained spaces will be added.
- Sustainability is incorporated at all levels of design, implementation and maintenance.
- Equitable access is provided to all public areas.
- Extensive parks and tree planting provide shade, shelter and respite.
- Water is incorporated across the site for amenity and to visibly express the innovative Water Reclamation Management Scheme (WRAMS).

## 1.5 Provision for Major Events

The Sydney Olympic Park Public Domain has been purpose designed for large events that will continue to be hosted at the park on a frequent basis. The following strategies enable large events to be hosted successfully in the park.

- Squares, parks and footpaths near the main stadiums are generously sized.
- Kerbs are flush to facilitate equal access in the busiest parts of the Public Domain.
- Kerb ramps are generously scaled.
- Light poles in event areas have the potential for brackets for banners and attachment and connection of communications equipment.
- Light standards in event areas incorporate provisions for low voltage power, communications and 3 phase power.
- Directional signs in event areas are detachable to allow for changes of venue name/purpose in event mode.
- Placement guidelines consider major crowd movements and clear paths of travel for access.
- The Plaza Pylons, with their easily-modified dynamic signage and capacity to accommodate permanent and temporary facilities, have been developed specifically for major events.

## 1.6 Access Considerations

The strong drive to provide equal access established during the Olympics has been continued in the UEDM. This has been developed in close collaboration with access consultants, to meet or better AS1428.4 for paving, lighting, street furniture and signage, with many elements, including tree grates, paving and bollards, being specifically designed or modified to meet access requirements. The key recommendation of the Access Strategy is to provide consistent linkages to, within and between all Sydney Olympic Park venues and facilities.

The implementation of the recommendations of the UEDM will ensure a consistent approach to access in the Public Domain.

## 1.7 Structure of UEDM 2008

The UEDM 2008 is divided into 3 main sections as outlined below.

### 1. Introduction

This section explains the background and structure of the UEDM.

### 2. Placement and Co-ordination

In addition to describing the new streets, this section sets out the placement and Co-ordination principles for intersections and the arrangement of public domain elements within streets.

### 3. Urban Elements and Details

This section provides technical details and specification for the public domain elements. It is divided into 6 chapters.

- 3.1 Pavements and Level Changes
- 3.2 Street Furniture
- 3.3 Lighting
- 3.4 Engineering Elements
- 3.5 Street Tree Planting
- 3.6 Signage

## 1.8 Public Domain Procurement

The procurement of items within the Public Domain is the overall responsibility of the Sydney Olympic Park Authority, and has been subject to the probity requirements of Government tendering and supply. Manufacturers are listed where known. Shop drawings and detailed component lists are available from SOPA on request. Procurement of urban elements must comply with the NSW Government procurement policies. Material selection shall be in accordance with the Materials Selection objectives section of the SOPA 'Environmental Guidelines'.

## 1.9 Use of UEDM

This document is for design guidance purposes. Detailed design by qualified and experienced landscape architecture, engineering and related consultants is required for construction projects. All work is to comply with relevant Australian Standards and Building Code of Australia requirements. If discrepancies occur between given dimensions and AS and BCA requirements you are required to seek advice from SOPA before proceeding.

## 1.10 Public Domain Plans

Public Domain plans (extending from the building frontage to the kerb) including cross and long sections and specifications are to be prepared and submitted for approval for all new buildings, streets or parts of streets and must meet the following requirements.

The plans are to be drawn at minimum scale 1:200.

The plans are to show:

- all existing trees and other urban elements;
- the main building line showing pedestrian and vehicular entrances;
- awnings and colonnades;
- kerbs, kerb ramps and vehicle cross overs;
- pavement types and detail;
- kerb, stairs, handrails, ramps and balustrades;

- street furniture including signs and parking meters;
- services, pit lids and drainage;
- lights;
- trees, tree pits and garden beds including irrigation and subsoil drainage;
- plant species, sizes and location;
- public art; and
- levels at the entrances, building line, top of kerb and bottom of kerb.

The longitudinal sections are to be at minimum scale 1:100.

Cross sections are to be drawn at minimum 10m intervals at minimum scale 1:50 (with 1:10 exaggerated vertical scale) including pavements and sub base and proposed cross falls.

## 1.11 Park and Urban Squares Plans

Plans for all new parks and urban squares are to be prepared for approval. With the exception of trees, the UEDM doesn't specify elements for particular parks and urban squares as these areas are subject to individual designs. However, these areas form part of the Sydney Olympic Park Public Domain and are to be designed and detailed to reflect and reinforce the strategies and elements described in the UEDM.

## 1.12 CHECKLIST FOR PUBLIC DOMAIN DELIVERY

This checklist is a guide to the level of information required at each stage of development within the town centre.

While the UEDM is provided as a technical reference document to clearly set out design intent and performance standards for the public domain, liaison with the Authority prior to lodgement is recommended to resolve many site specific issues and expedite development consent.

It is recommended that a Registered Landscape Architect prepare these applications.

STEP 1	<b>PRELIMINARY</b>
	<p>Liaison with Authority staff during preliminary stages will assist you to identify :</p> <ul style="list-style-type: none"> <li>critical operational requirements</li> <li>interface issues with existing public domain areas</li> <li>confirm relevant development guidelines and standards</li> </ul>
STEP 2	<b>DEVELOPMENT ASSESSMENT</b>
	<ul style="list-style-type: none"> <li>prepare coordinated Public Domain plans @ 1:200 scale with all material finishes, siting of street furniture, public lighting, access elements and any proposed commercial outdoor seating zones</li> <li>prepare proposed external levels plan indicating survey of existing kerb, road and ramp levels and proposed finished ground floor levels</li> <li>prepare planting plan with existing trees proposed to be retained and/or removed, new trees and planting with a complete schedule of species, planting densities and container sizes</li> <li>Obtain Land Owners Consent if required</li> <li>Assessment by Department of Planning or delegation to SOPA</li> <li>Determination</li> </ul>
STEP 3	<b>IMPLEMENTATION</b>
	<p>Prior to commencement of works, the following information is required to be lodged with the Authority for coordination and review :</p> <ul style="list-style-type: none"> <li>setout information coordinated with existing infrastructure and services</li> <li>construction details for all hard and soft landscape elements</li> <li>technical notes and performance specifications</li> </ul>
STEP 4	<b>PRACTICAL COMPLETION</b>
	<ul style="list-style-type: none"> <li>prepare and submit as-built Public Domain plans to reflect amendments required during construction phase</li> </ul>



# Placement and Co-ordination

Urban Elements Design Manual  
Section

# 2.0

ISBN 978-0-9805976-1-5

© All rights reserved. No part of this work will be reproduced, translated, modified, transmitted or stored in any form by any means without the prior permission of Sydney Olympic Park Authority.



Placement and Co-ordination

# Street Hierarchy and Types

Urban Elements Design Manual

Section

# 2.1

ISBN 978-0-9805976-1-5

© All rights reserved. No part of this work will be reproduced, translated, modified, transmitted or stored in any form by any means without the prior permission of Sydney Olympic Park Authority.



## 2.1 Placement and Co-ordination

Correct placement and Co-ordination of urban elements is essential to good streetscape and public domain design. Well placed and coordinated elements:

- reinforce the street hierarchy;
- provide required paths of travel;
- provide a clear and direct composition that reinforces the major design elements;
- are integrated seamlessly into the paved ground plane;
- suit the location of other street elements; and
- are located consistently throughout the Public Domain to reflect the overall special character.

### 2.1 Street Types

In the following section the draft street masterplan and indicative section and plan of each street type plus a summary of the public domain elements that are proposed for each street type.

## Streets Master Plan

Draft Sydney Olympic Masterplan 2030  
Section 4: refer to Sydney Olympic  
Masterplan 2030 for final street layout.

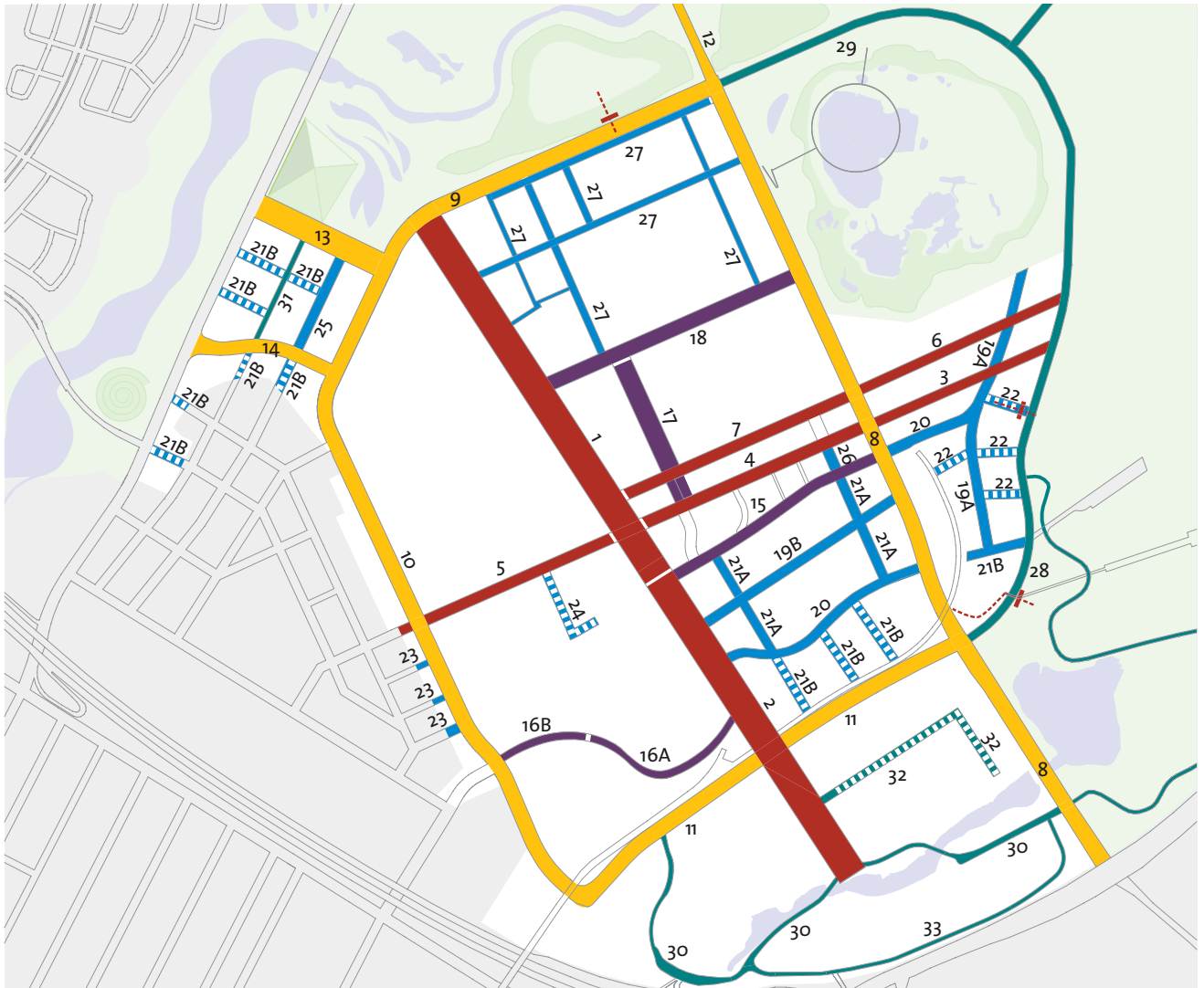

Civic Streets	Perimeter Avenues	Town Streets	Local Streets	Park Edge Streets
1 Olympic Boulevard North	8 Australia Avenue	15 Herb Elliott Avenue	19A Median Street	28 Bennelong Parkway
2 Olympic Boulevard South	9 Kevin Coombs Avenue	16A Shane Gould Avenue East	19B East West Street	29 Majorie Jackson Parkway
3 Dawn Fraser Avenue East	10 Edwin Flack Avenue	16B Shane Gould Avenue West	20 Figtree Avenue & Parkview Drive	30 Shirley Strickland Avenue
4 Dawn Fraser Avenue Central	11 Sarah Durack Avenue	17 Showground Road	21A North South Street	31 Park Edge Street Haslams
5 Dawn Fraser Avenue West	12 Holker Street	18 Grand Parade	21B Verge Street	32 Park Edge Street Boundary Creek
6 Murray Rose Avenue East	13 Pondage Link Road		22 Pedestrian Street	33 Rod Laver Drive
7 Murray Rose Avenue Central	14 Old Hill Road		23 Shared Way	
			24 Car Parking Street	
			25 Coach Parking Street	
			26 Park Street	
			27 Showground Street	

 Authority Funded Streets  
 Development Funded Streets

Note: Highlighted in *italics*, are new additional streets to be implemented under Master Plan 2030.

## S1 Olympic Boulevard North

For arrangement and urban elements refer to the following details:

### 3.1 Pavements and Level Changes

- P8 for footpath pavement
- P9 for footpath pavement
- P14 for kerb ramp

### 3.2 Street Furniture

- SF02 for seats
- SF03 for bus shelter
- SF24 for bins

### 3.3 Lighting

- LA3 for street lighting

### 3.4 Engineering Elements

- E1 for kerb and gutter
- E2 for kerb and gutter

### 3.5 Street Tree Planting

- T1 for planting species

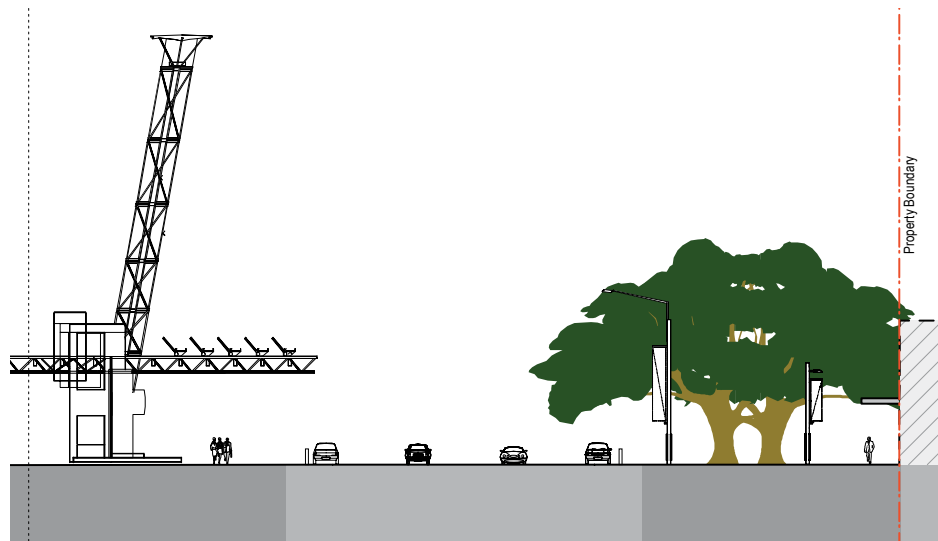
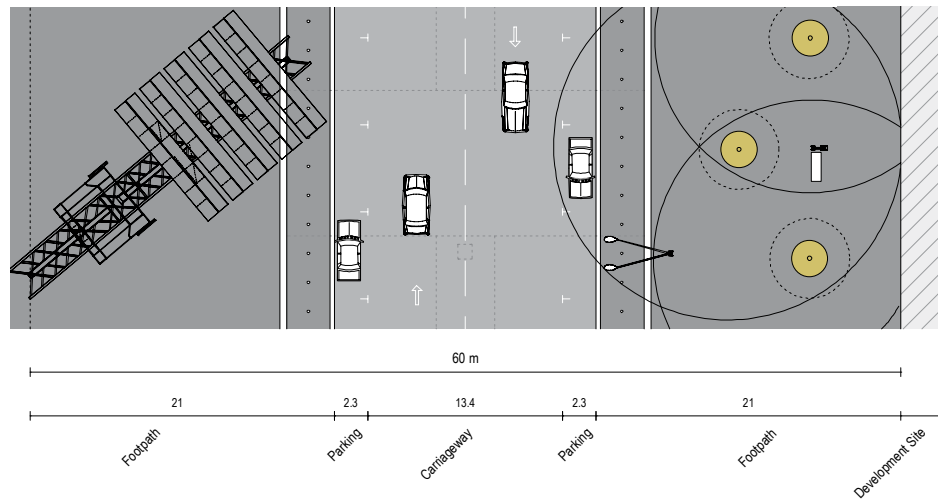

Figure C2b Olympic Boulevard North – Indicative Plan



## S2 Olympic Boulevard South

For arrangement and urban elements refer to the following details:

- 3.1 Pavements and Level Changes**
  - P8\* for footpath pavement
  - P9\* for footpath pavement
  - P14 for kerb ramp
- 3.2 Street Furniture**
  - SF02 for seats
  - SF03 for bus shelter
  - SF24 for bins
- 3.3 Lighting**
  - LA3 for street lighting
- 3.4 Engineering Elements**
  - E1 for kerb and gutter
- 3.5 Street Tree Planting**
  - T1 for planting species

\* Note: Existing pedestrian pavement to be extended.



Figure C3b Olympic Boulevard South – Indicative Plan

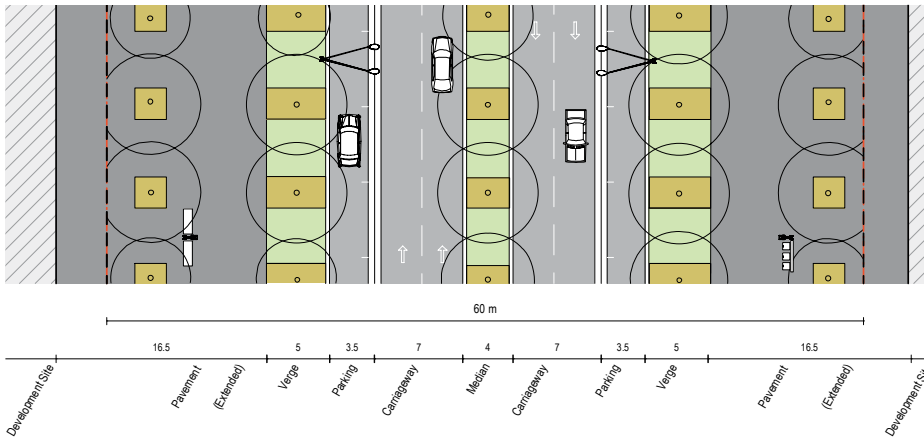

### S3 Dawn Fraser East

For arrangement and urban elements refer to the following details:

- 2.2 Placement and Co-ordination**  
 PCa for urban element placement  
 PCb for urban element placement
- 3.1 Pavements and Level Changes**  
 P8\* for footpath pavement  
 P9\* for footpath pavement  
 P14 for kerb ramp
- 3.2 Street Furniture**  
 SF02 for seats
- 3.3 Lighting**  
 LA3 for street lighting
- 3.4 Engineering Elements**  
 E4 for kerb and gutter
- 3.5 Street Tree Planting**  
 T1 for planting species  
 T4 for street tree planting

\* Note: Existing footpath to be upgraded.

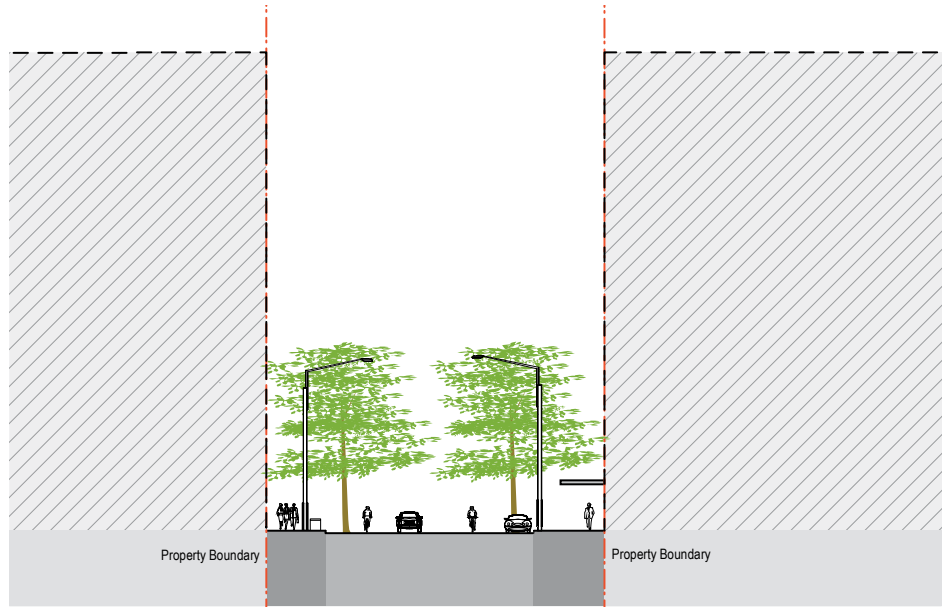
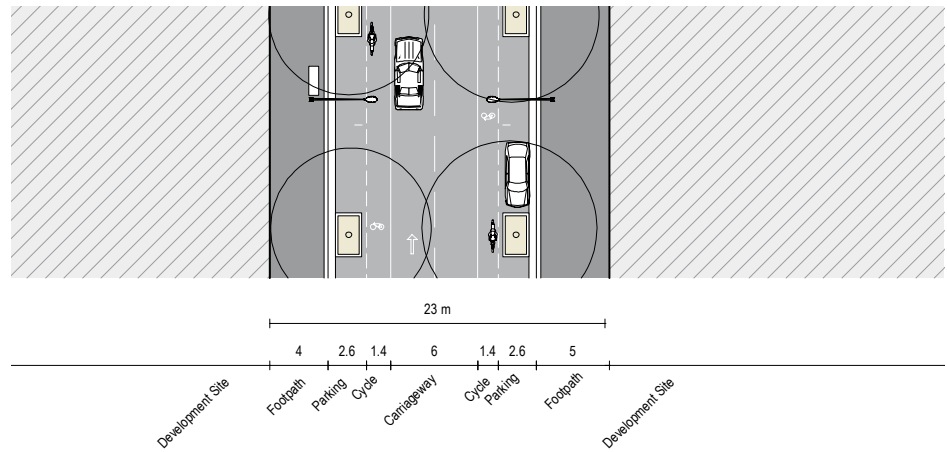

Figure C4b Dawn Fraser Avenue East – Indicative Plan



## S4 Dawn Fraser Avenue Central

For arrangement and urban elements refer to the following details:

- 2.2 Placement and Co-ordination**
  - PCa for urban element placement
- 3.1 Pavements and Level Changes**
  - P8 for footpath pavement
  - P9 for footpath pavement
  - P14 for kerb ramp
- 3.2 Street Furniture**
  - SFO2 for seats
  - SF24 for bins
  - SF10 for tree surround in footpath
- 3.3 Lighting**
  - LA3 for street lighting
- 3.4 Engineering Elements**
  - E4 for kerb and gutter
- 3.5 Street Tree Planting**
  - T1 for planting species
  - T5 for street tree planting

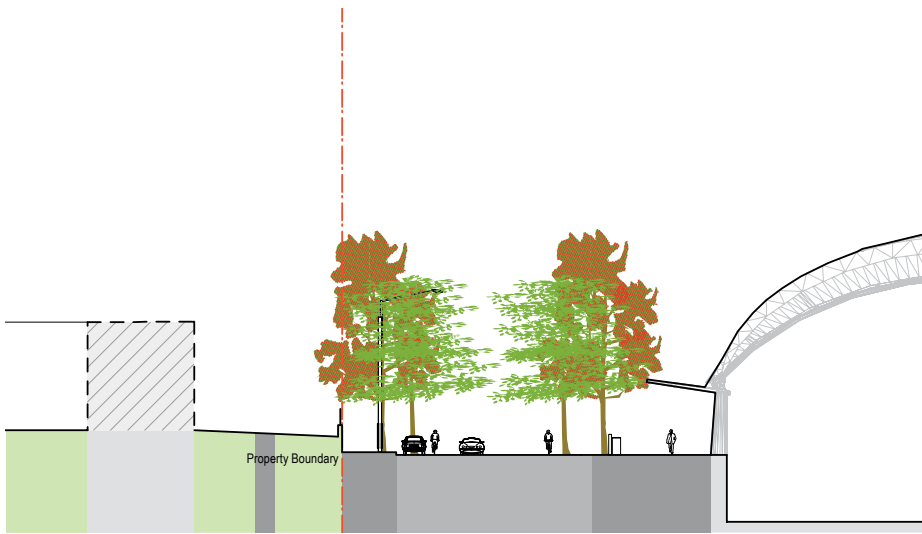
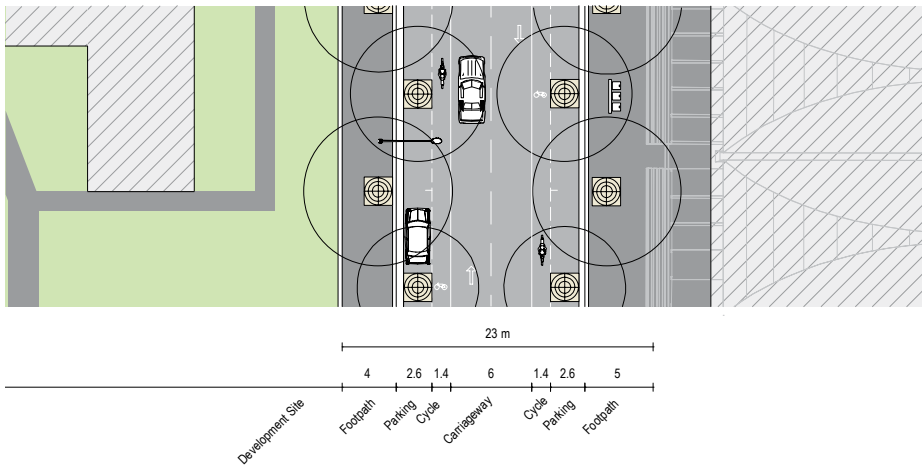

Figure C5b Dawn Fraser Avenue Central – Indicative Plan



## S5 Dawn Fraser Avenue West

For arrangement and urban elements refer to the following details:

- 2.2 Placement and Co-ordination**  
PCa for urban element placement
- 3.1 Pavements and Level Changes**  
P8 for footpath pavement  
P9 for footpath pavement  
P14 for kerb ramp
- 3.2 Street Furniture**  
SFo2 for seats  
SF1o for tree surround in footpath
- 3.3 Lighting**  
LA3 for street lighting
- 3.4 Engineering Elements**  
E4 for kerb and gutter
- 3.5 Street Tree Planting**  
T1 for planting species  
T5 for street tree planting

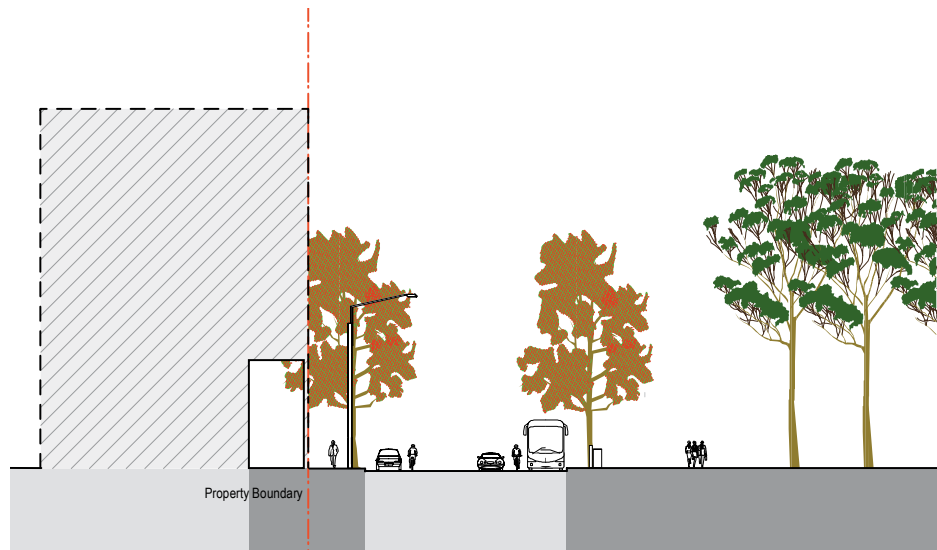
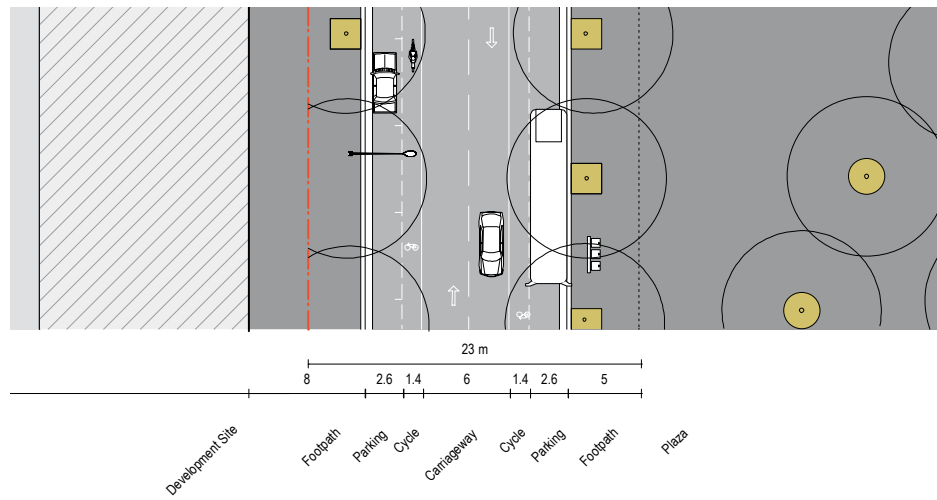

Figure C6b Dawn Fraser Avenue West – Indicative Plan



## S6 Murray Rose Avenue East

For arrangement and urban elements refer to the following details:

- 2.2 Placement and Co-ordination**  
PCb for urban element placement
- 3.1 Pavements and Level Changes**  
P8 for permeable paving  
P9 for footpath paving  
P14 for kerb ramp
- 3.2 Street Furniture**  
SFO2 for seats
- 3.3 Lighting**  
LA3 for street lighting
- 3.4 Engineering Elements**  
E4 for kerb and gutter
- 3.5 Street Tree Planting**  
T1 for planting species  
T3 for tree planting in verge

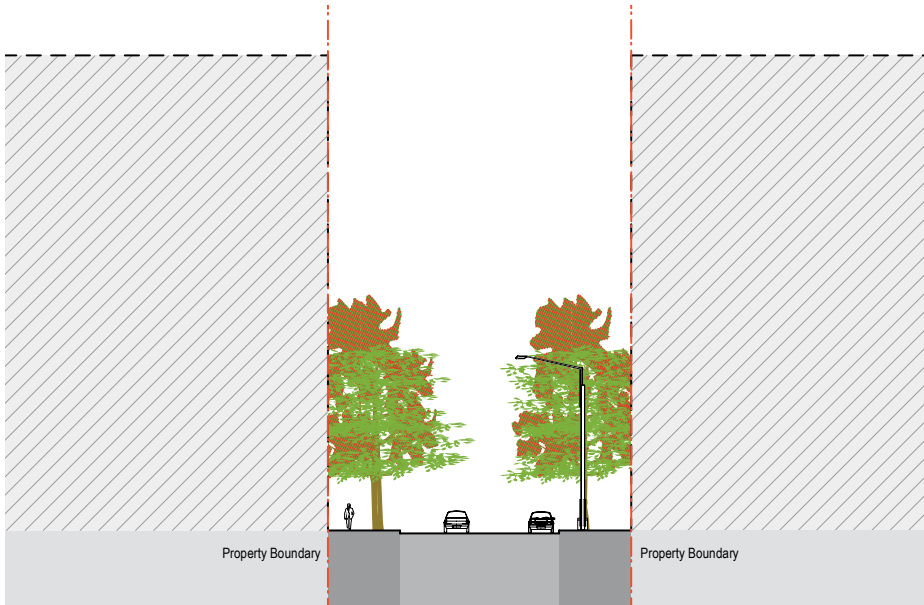
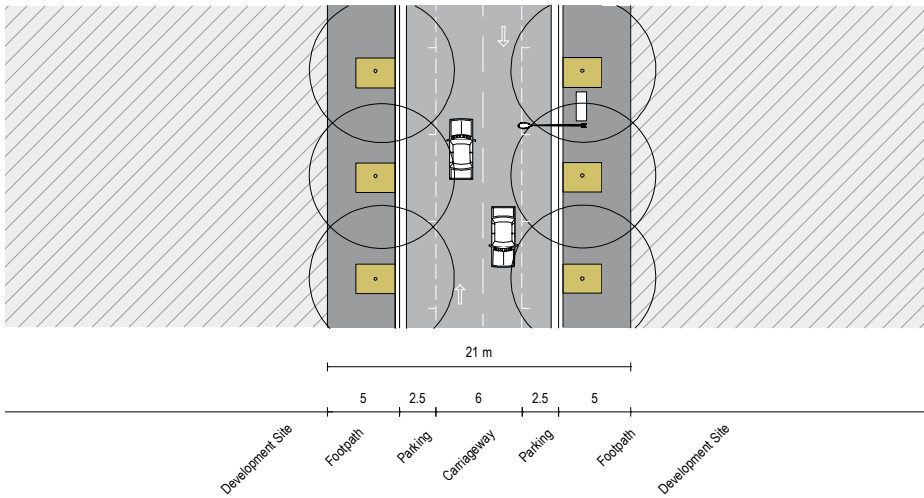

Figure C7b Murray Rose Avenue East – Indicative Plan





## S7 Murray Rose Avenue Central

For arrangement and urban elements refer to the following details:

### 2.2 Placement and Co-ordination

PCa for urban element placement

### 3.1 Pavements and Level Changes

P8 for footpath pavement  
 P9 for footpath pavement  
 P14 for kerb ramp

### 3.2 Street Furniture

SF02 for seats  
 SF24 for bins  
 SF10 for tree surround in footpath

### 3.3 Lighting

LA3 for street lighting

### 3.4 Engineering Elements

E4 for kerb and gutter

### 3.5 Street Tree Planting

T1 for planting species  
 T5 for street tree planting

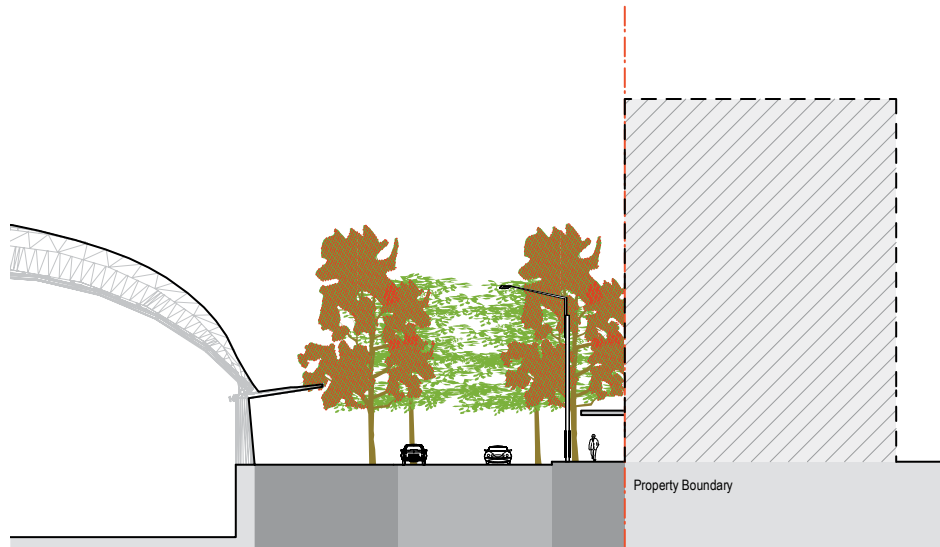
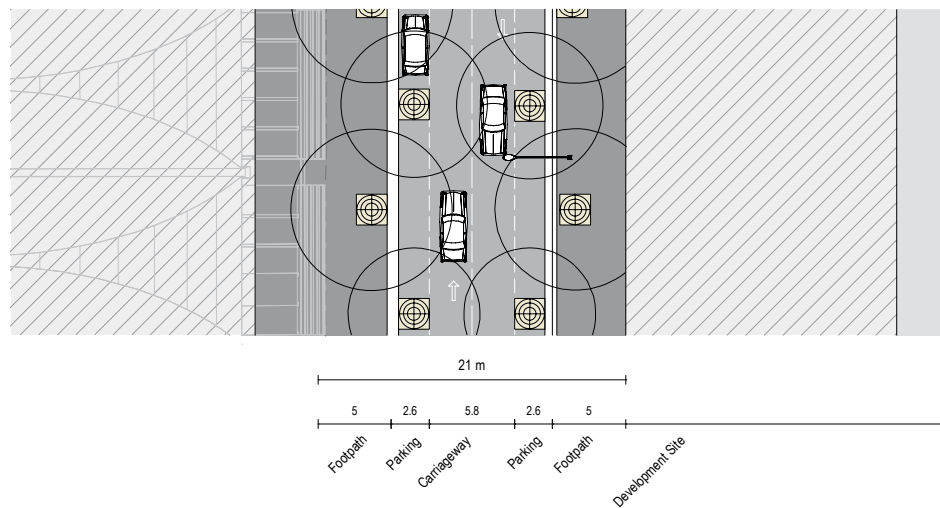

Figure C8b Murray Rose Avenue Central – Indicative Plan



### S8 Australia Avenue

For arrangement and urban elements refer to the following details:

- 3.1 Pavements and Level Changes**
  - P12 for footpath pavement
  - P14 for kerb ramp
- 3.2 Street Furniture**
  - SF02 for seats
  - SF24 for bins
  - SF18 for bus shelter
- 3.3 Lighting**
  - LA3 for street lighting
- 3.4 Engineering Elements**
  - E3 for kerb and gutter
- 3.5 Street Tree Planting**
  - T1 for planting species

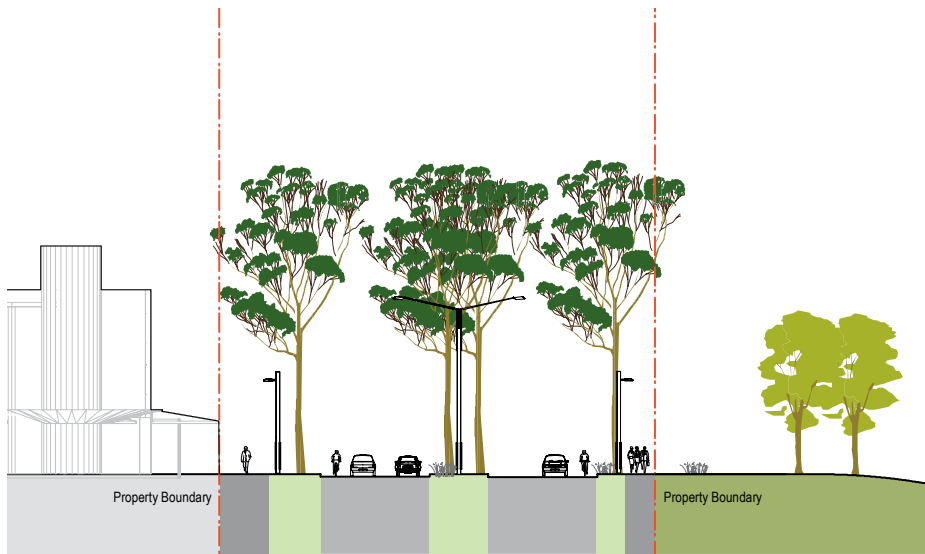
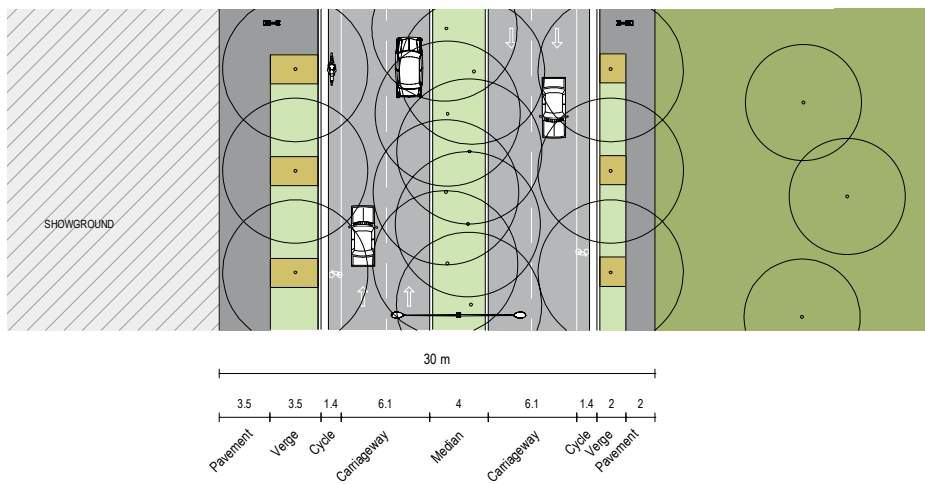

Figure C9b Australia Avenue – Indicative Plan



## S9 Kevin Coombs Avenue

For arrangement and urban elements refer to the following details:

### 3.1 Pavements and Level Changes

- P12 for footpath pavement
- P14 for kerb ramp

### 3.2 Street Furniture

- SF02 for seats
- SF24 for bins
- SF18 for bus shelter

### 3.3 Lighting

- LA3 for street lighting

### 3.4 Engineering Elements

- E3 for kerb and gutter

### 3.5 Street Tree Planting

- T1 for planting species

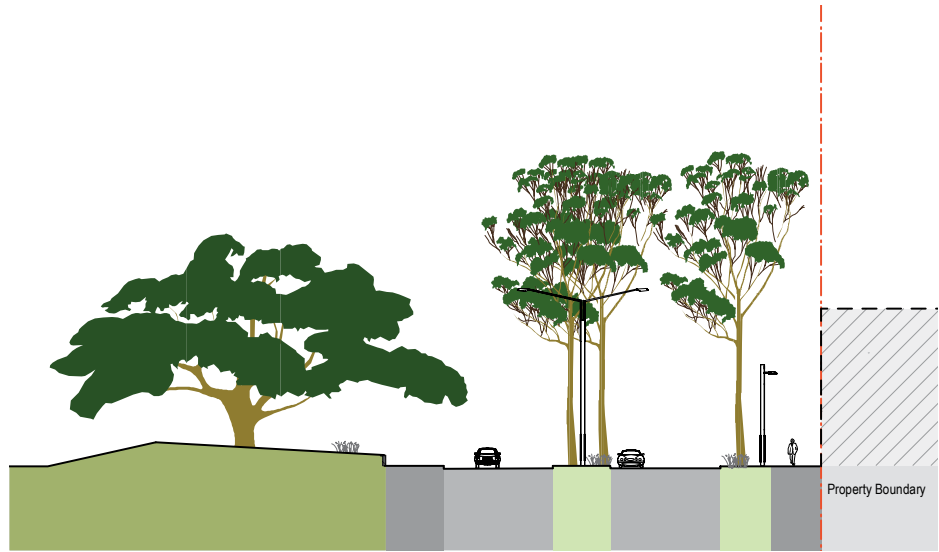
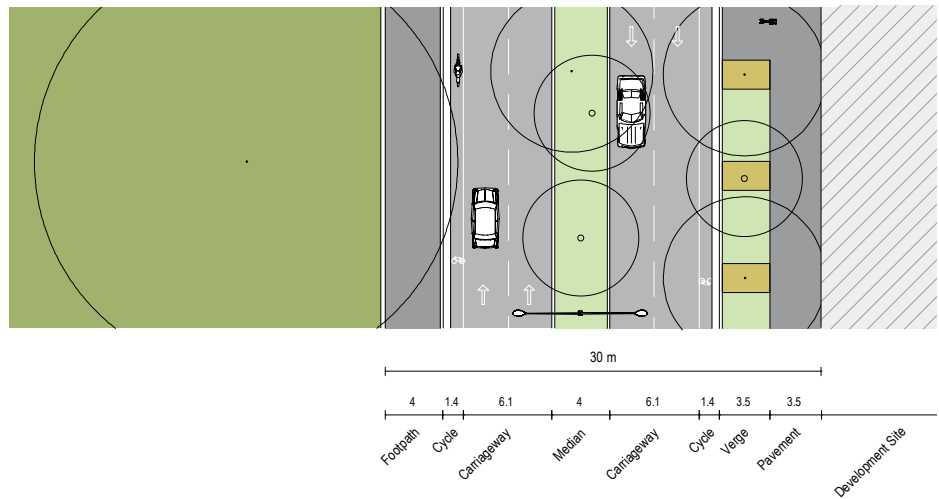

Figure Crob Kevin Coombs Avenue – Indicative Plan



### S10 Edwin Flack Avenue

For arrangement and urban elements refer to the following details:

- 3.1 Pavements and Level Changes**
  - P12 for footpath pavement
  - P14 for kerb ramp
- 3.2 Street Furniture**
  - SF02 for seats
  - SF24 for bins
  - SF18 for bus shelter
- 3.3 Lighting**
  - LA3 for street lighting
- 3.4 Engineering Elements**
  - E3 for kerb and gutter
- 3.5 Street Tree Planting**
  - T1 for planting species

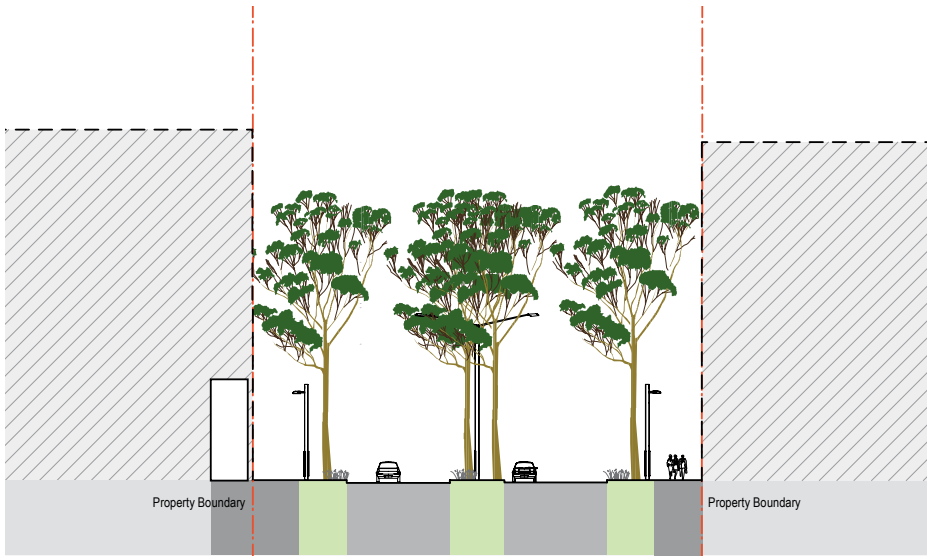
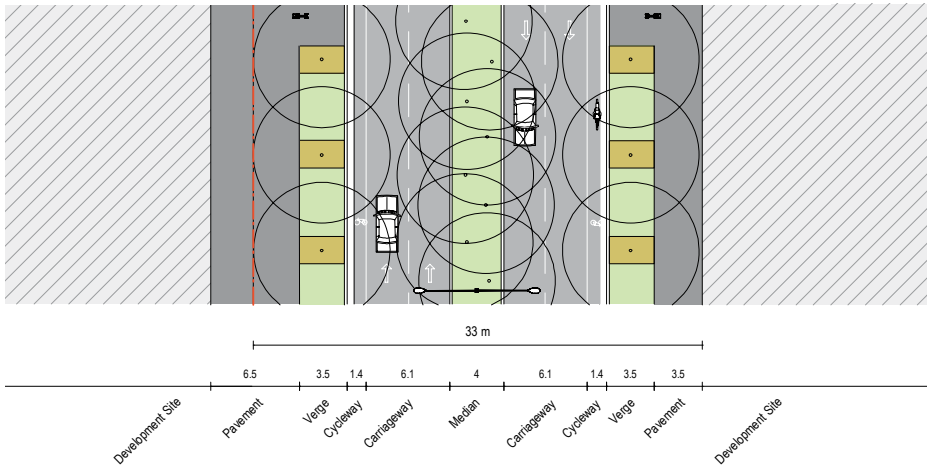

Figure C11b Edwin Flack Avenue – Indicative Plan



## S11 Sarah Durack Avenue

For arrangement and urban elements refer to the following details:

### 3.1 Pavements and Level Changes

- P12 for footpath pavement
- P14 for kerb ramp

### 3.2 Street Furniture

- SF02 for seats
- SF24 for bins
- SF18 for bus shelter

### 3.3 Lighting

- LA3 for street lighting

### 3.4 Paving

- E3 for kerb and gutter

### 3.5 Street Tree Planting

- T1 for planting species

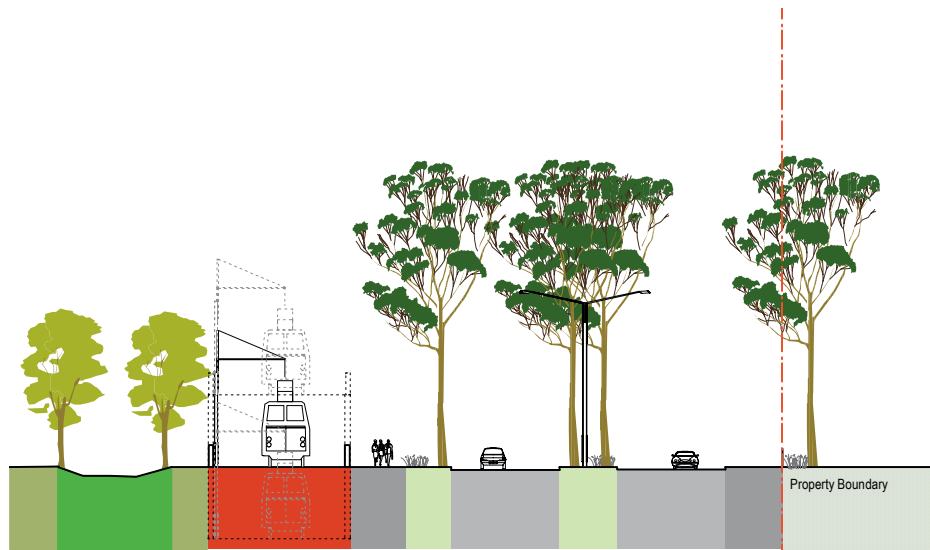
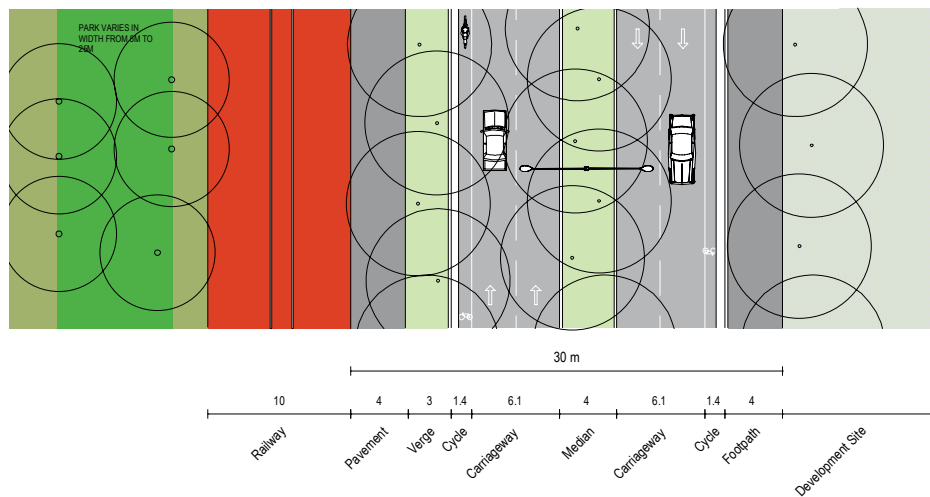

Figure C12b Sarah Durack Avenue – Indicative Plan



## S12 Holker Street

For arrangement and urban elements refer to the following details:

- 3.1 Pavements and Level Changes**
  - P12 for footpath pavement
  - P14 for kerb ramp
- 3.2 Street Furniture**
  - no seats
  - no bins
- 3.3 Lighting**
  - LA3 for street lighting
- 3.4 Engineering Elements**
  - E3 for kerb and gutter
- 3.5 Street Tree Planting**
  - T1 for planting species

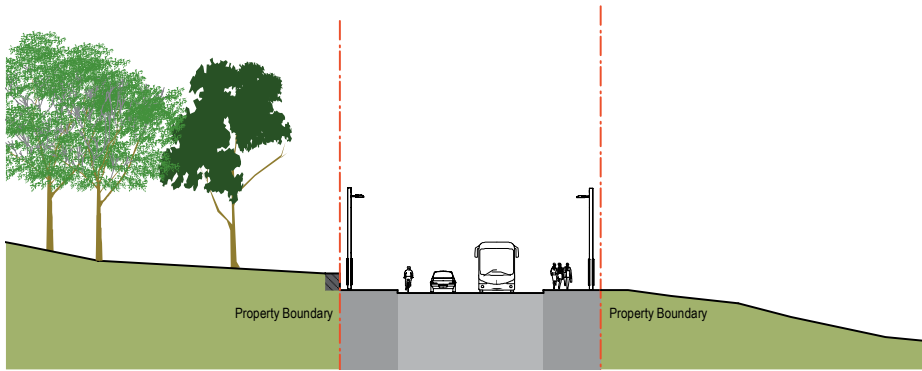
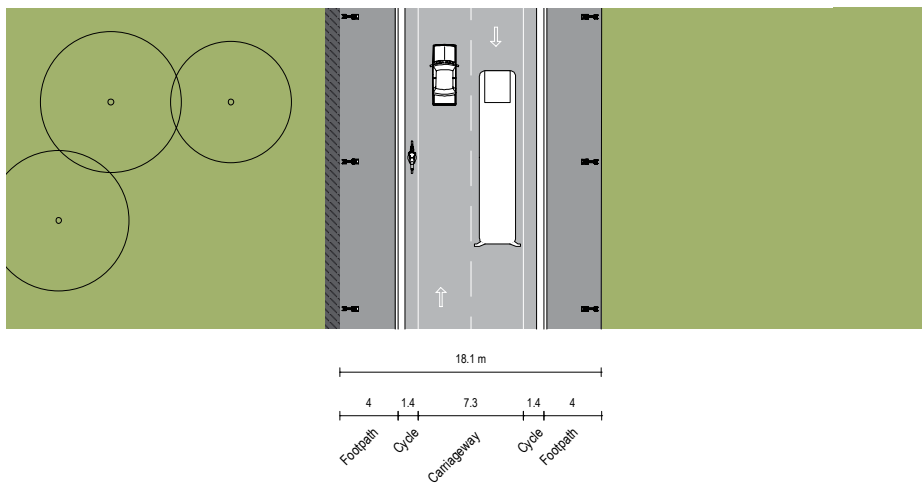

Figure C13b Holker Street – Indicative Plan



### S13 Pondage Link Road

For arrangement and urban elements refer to the following details:

**3.1 Pavements and Level Changes**

- P12 for footpath pavement
- P14 for kerb ramp

**3.2 Street Furniture**

- no seats
- no bins

**3.3 Lighting**

- LA3 for street lighting

**3.4 Engineering Elements**

- E3 for kerb and gutter

**3.5 Street Tree Planting**

- T1 for planting species

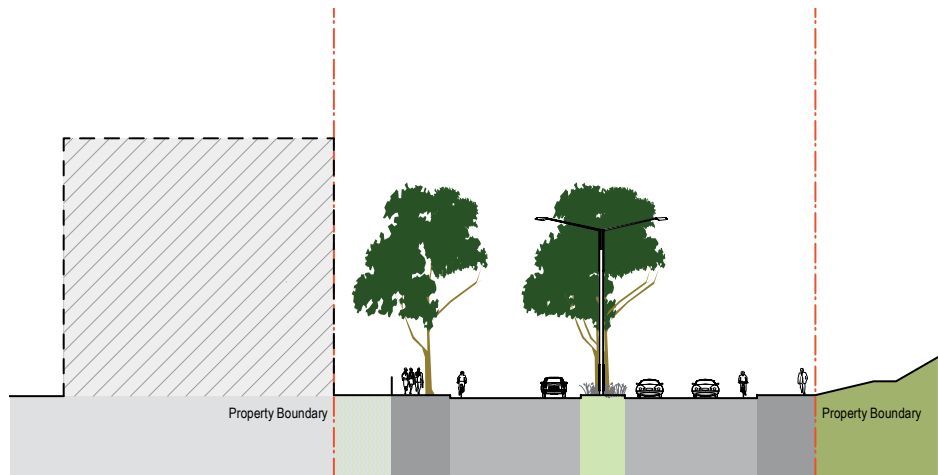
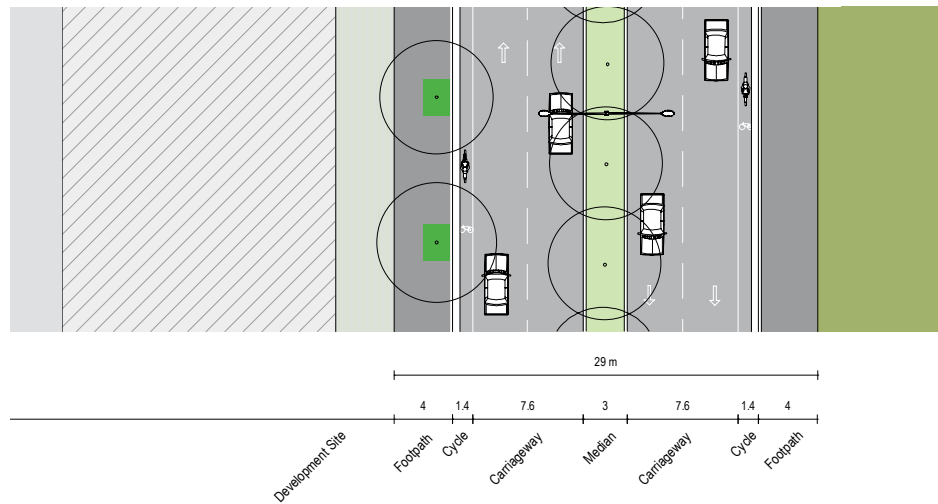

Figure C14b Pondage Link – Indicative Plan



### S14 Old Hill Road

For arrangement and urban elements refer to the following details:

- 3.1 Pavements and Level Changes**
  - P12 for footpath pavement
  - P14 for kerb ramp
- 3.2 Street Furniture**
  - no seats
  - no bins
- 3.3 Lighting**
  - LA3 for street lighting
- 3.4 Engineering Elements**
  - E3 for kerb and gutter
- 3.5 Street Tree Planting**
  - T1 for planting species

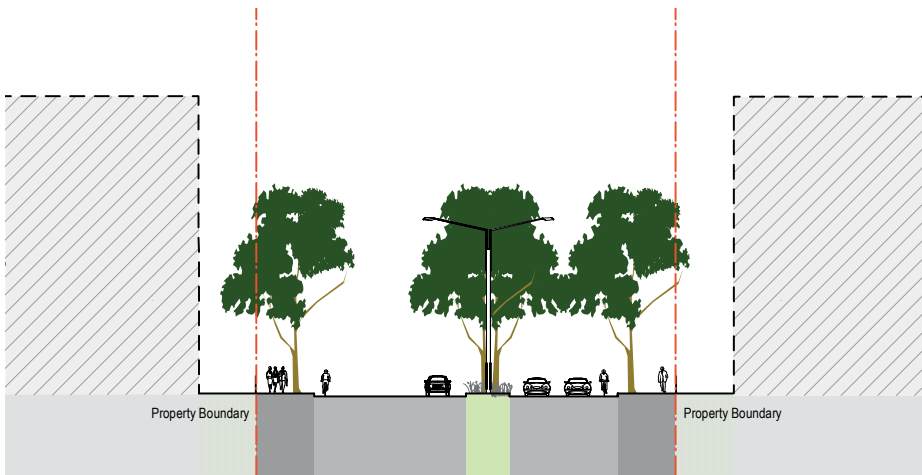
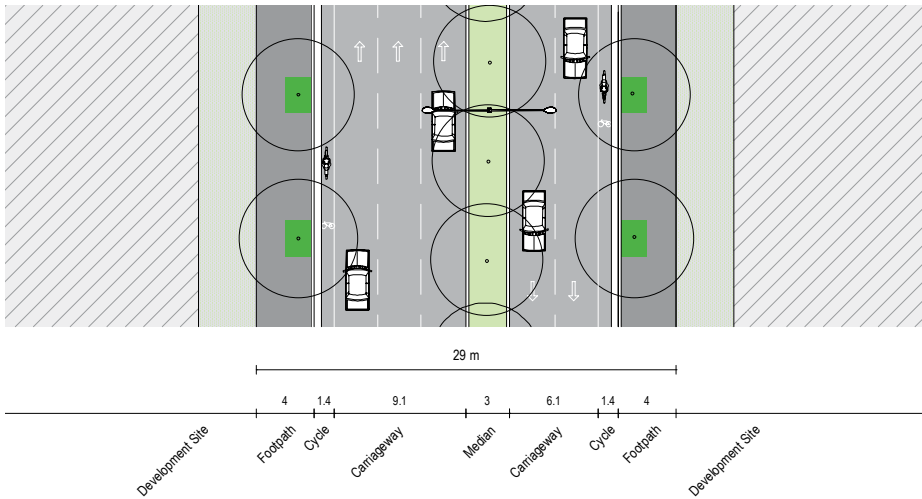

Figure C15b Old Hill Link – Indicative Plan





## S15 Herb Elliott Avenue

For arrangement and urban elements refer to the following details:

- 2.1 Placement and Co-ordination**  
PCa for urban element placement
- 3.1 Pavements and Level Changes**  
P11 for footpath paving  
P14 for kerb ramp
- 3.2 Street Furniture**  
SFO2 for seats  
SF10 for tree grate in footpath  
SF18 for bus shelter
- 3.3 Lighting**  
LA3 for street lighting
- 3.4 Engineering Elements**  
E4 for kerb and gutter
- 3.5 Street Tree Planting**  
T1 for planting species  
T5 for trees in footpath

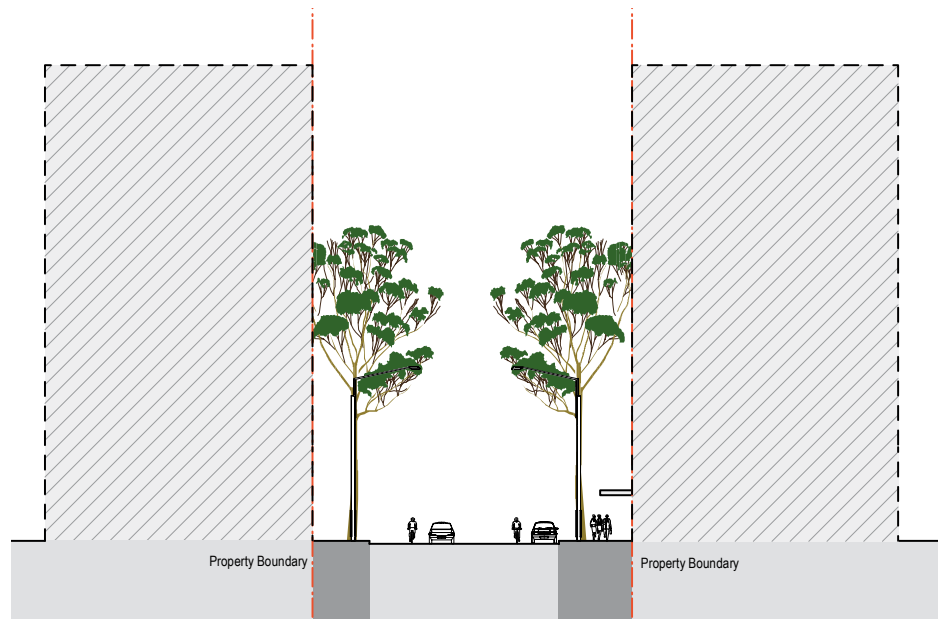
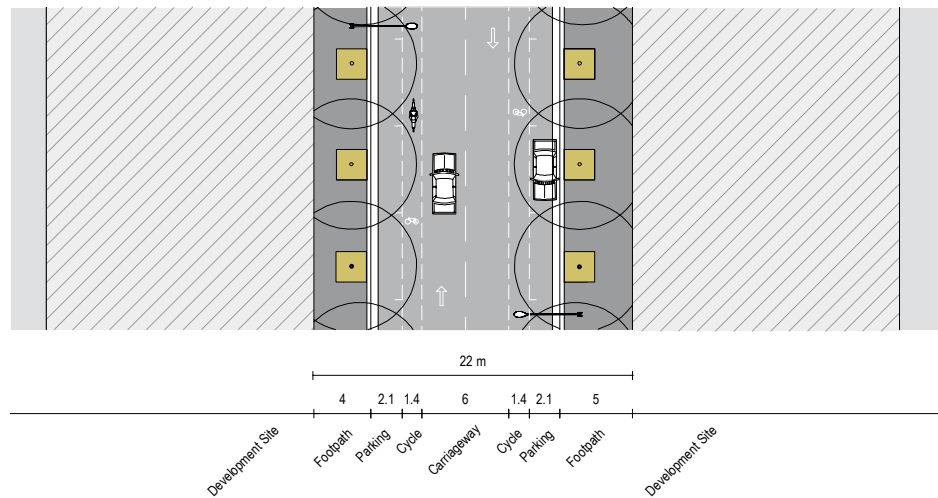

Figure C16b Herb Elliott Avenue – Indicative Plan



## S16A Shane Gould Avenue East

For arrangement and urban elements refer to the following details:

- 2.1 Placement and Co-ordination**  
PCa for urban element placement
- 3.1 Pavements and Level Changes**  
P11 for footpath paving  
P14 for kerb ramp
- 3.2 Street Furniture**  
SF02 for seats  
SF10 for tree grate in footpath
- 3.3 Lighting**  
LA3 for street lighting
- 3.4 Engineering Elements**  
E4 for kerb and gutter
- 3.5 Street Tree Planting**  
T1 for planting species  
T4 for trees in carriageway  
T5 for trees in footpath

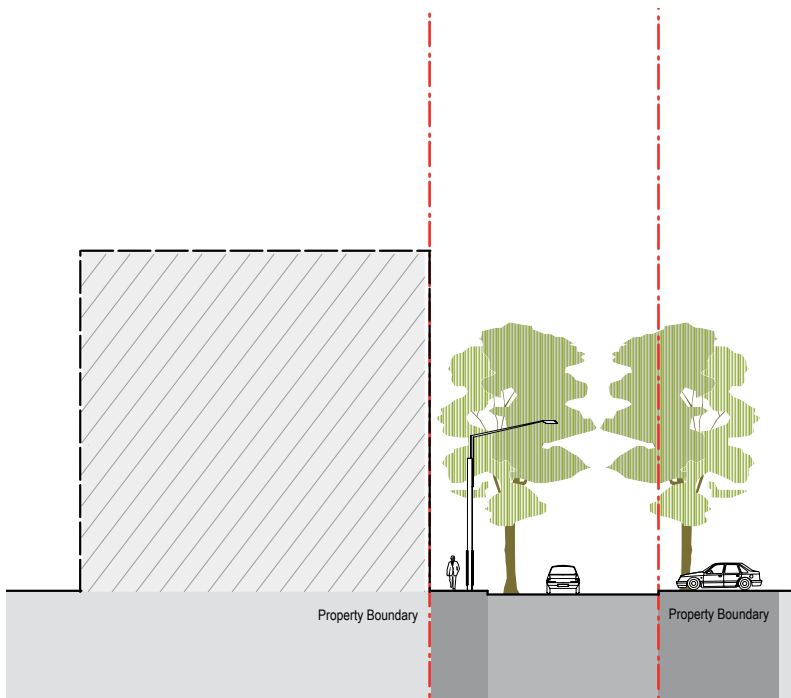

Figure C17b Shane Gould Avenue East – Indicative Plan



## S16B Shane Gould Avenue West

For arrangement and urban elements refer to the following details:

- 2.1 Placement and Co-ordination**  
PCa for urban element placement
- 3.1 Pavements and Level Changes**  
P11 for footpath paving  
P14 for kerb ramp
- 3.2 Street Furniture**  
SFO2 for seats  
SF10 for tree grate in footpath
- 3.3 Lighting**  
LA3 for street lighting
- 3.4 Engineering Elements**  
E4 for kerb and gutter
- 3.5 Street Tree Planting**  
T1 for planting species  
T4 for trees in carriageway  
T5 for trees in footpath

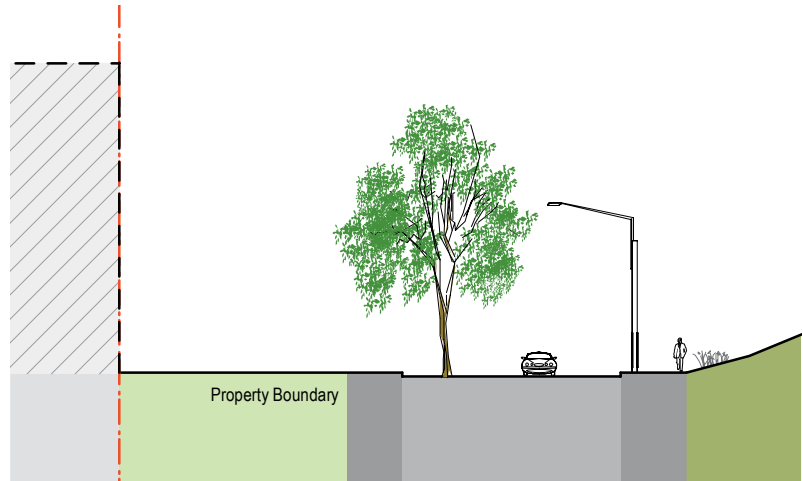
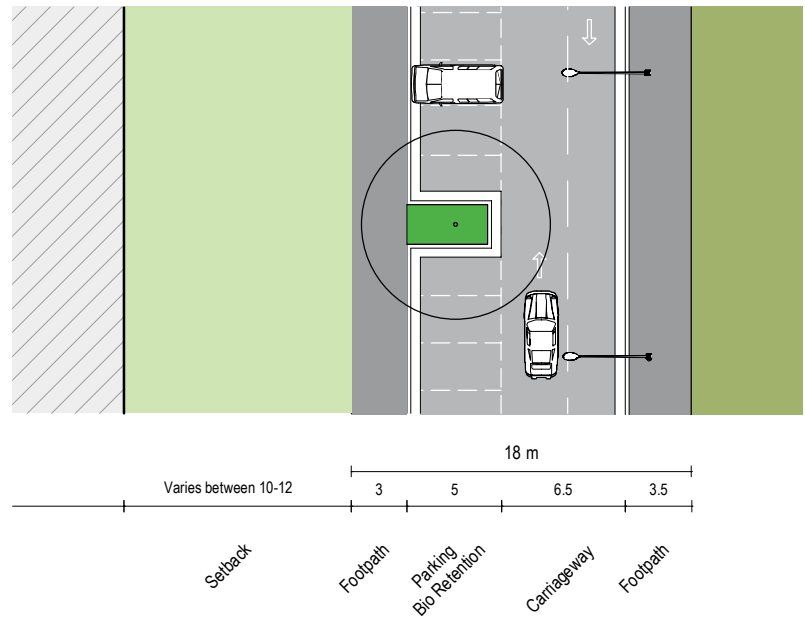

Figure C17d Shane Gould Avenue West – Indicative Plan



### S17 Showground Road

For arrangement and urban elements refer to the following details:

- 3.1 Pavements and Level Changes**  
Paths: exposed aggregate concrete to match existing  
P14 for kerb ramp
- 3.2 Street Furniture**  
SF02 for seats  
SF24 for bins  
SF10 for tree grate in footpath  
SF18 for bus shelter
- 3.3 Lighting**  
LA3 for street lighting
- 3.4 Engineering Elements**  
E6 for kerb and gutter
- 3.5 Street Tree Planting**  
T1 for planting species



Figure C18b Showground Road – Indicative Plan

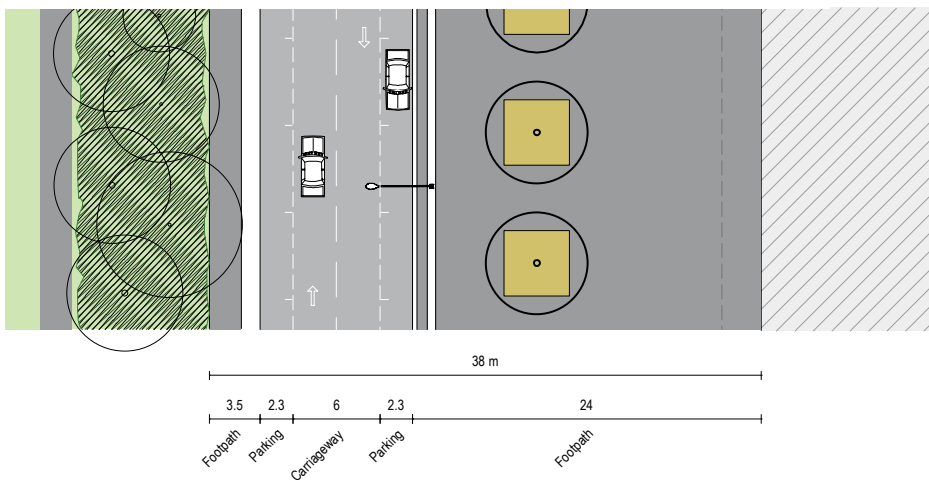

## S18 Grand Parade

For arrangement and urban elements refer to the following details:

- 3.1 Pavements and Level Changes**  
Paths: exposed aggregate concrete to match existing  
P14 for kerb ramp
- 3.2 Street Furniture**  
SF02 for seats  
SF24 for bins  
SF10 for tree grate in footpath  
SF18 for bus shelter
- 3.3 Lighting**  
LA3 for street lighting
- 3.4 Engineering Elements**  
E6 for kerb and gutter
- 3.5 Street Tree Planting**  
T1 for planting species

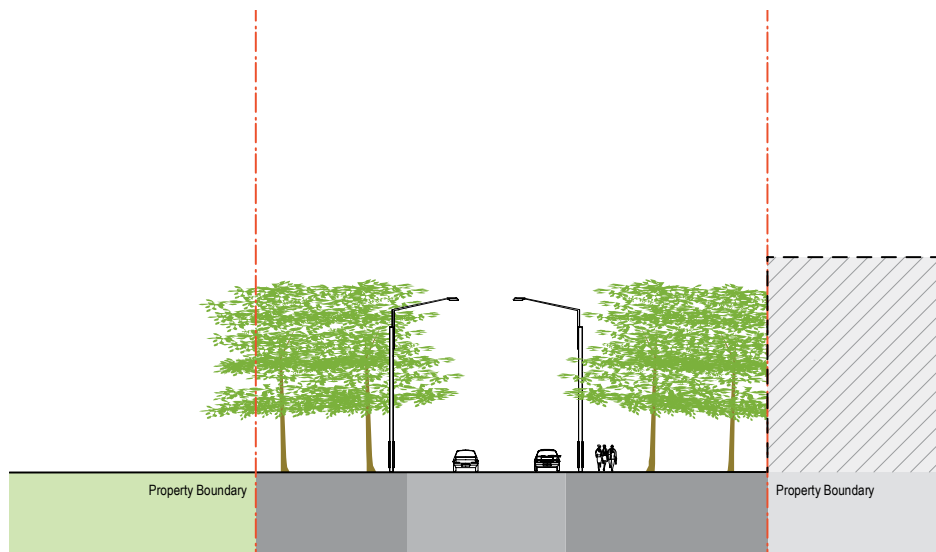
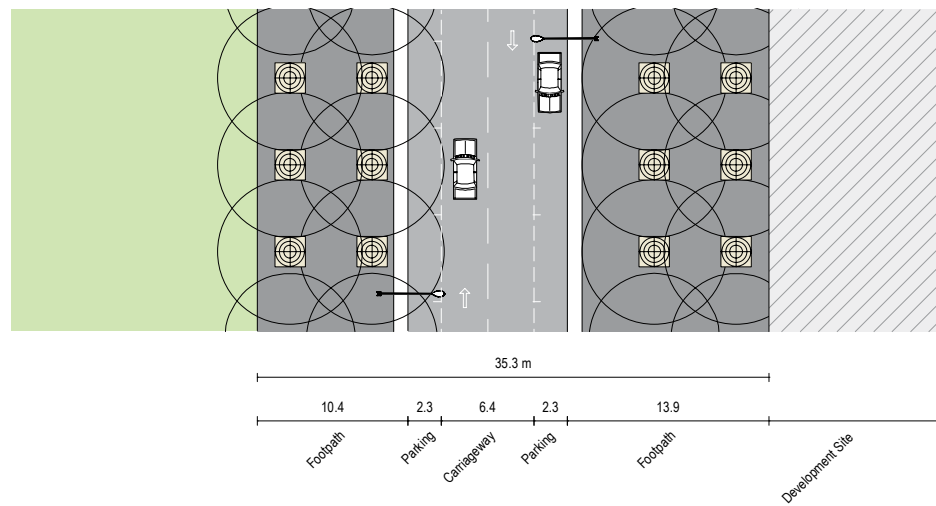

Figure C19b Grand Parade – Indicative Plan



## S19A Median Street

For arrangement and urban elements refer to the following details:

- 2.1 Placement and Co-ordination**  
PCb for urban element placement
- 3.1 Pavements and Level Changes**  
P12 for footpath paving  
P15 for kerb ramp
- 3.2 Street Furniture**  
no seats  
no bins
- 3.3 Lighting**  
LA3 for street lighting
- 3.4 Engineering Elements**  
E3 for kerb and gutter  
E7 for permeable median kerb
- 3.5 Street Tree Planting**  
T1 for planting species  
T2 for tree in verge

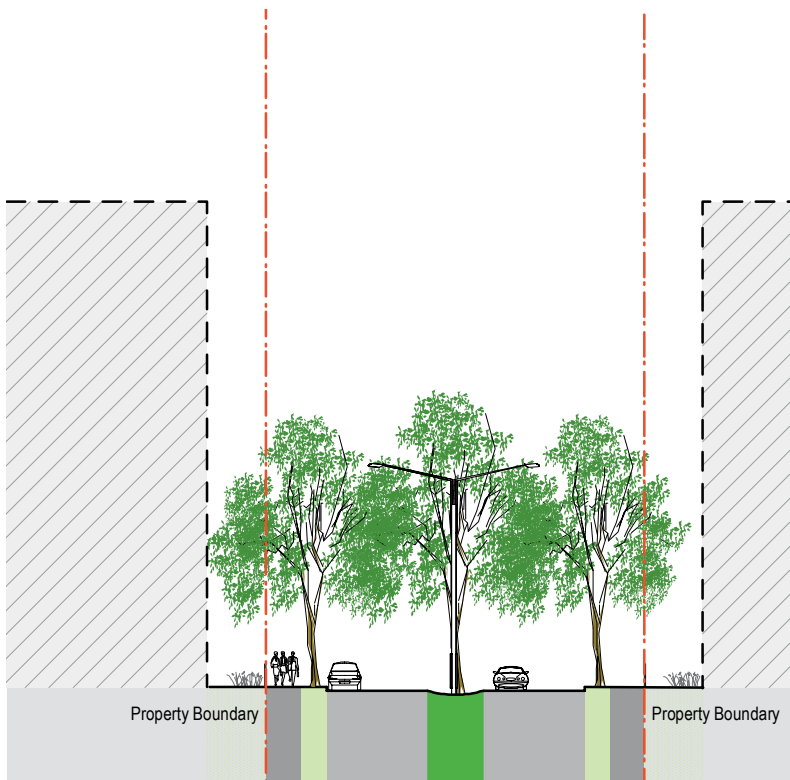
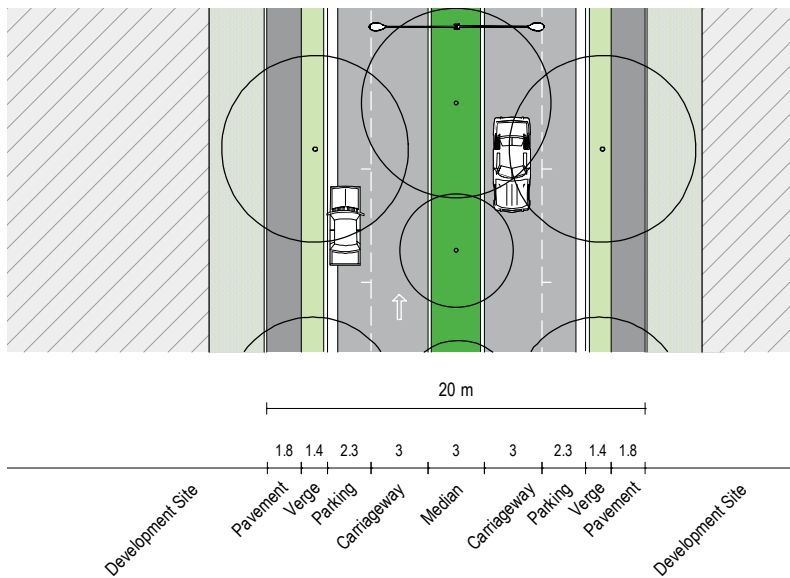

Figure C2ob Median Street – Indicative Plan



Principle

2008

DESIGN INTENT ONLY

Section 2.1  
Placement and Co-ordination

# S19A

## S19B East West Street

For arrangement and urban elements refer to the following details:

- 2.1 Placement and Co-ordination**  
PCb for urban element placement
- 3.1 Pavements and Level Changes**  
P12 for footpath paving  
P15 for kerb ramp
- 3.2 Street Furniture**  
no seats  
no bins
- 3.3 Lighting**  
LA3 for street lighting
- 3.4 Engineering Elements**  
E3 for kerb and gutter  
E7 for permeable median kerb
- 3.5 Street Tree Planting**  
T1 for planting species  
T2 for tree in verge

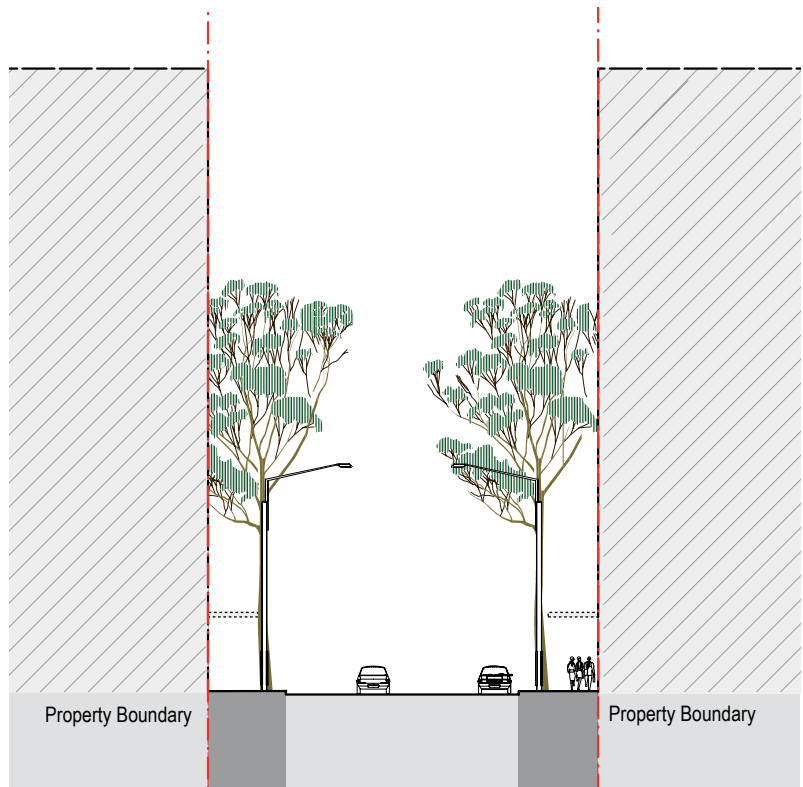
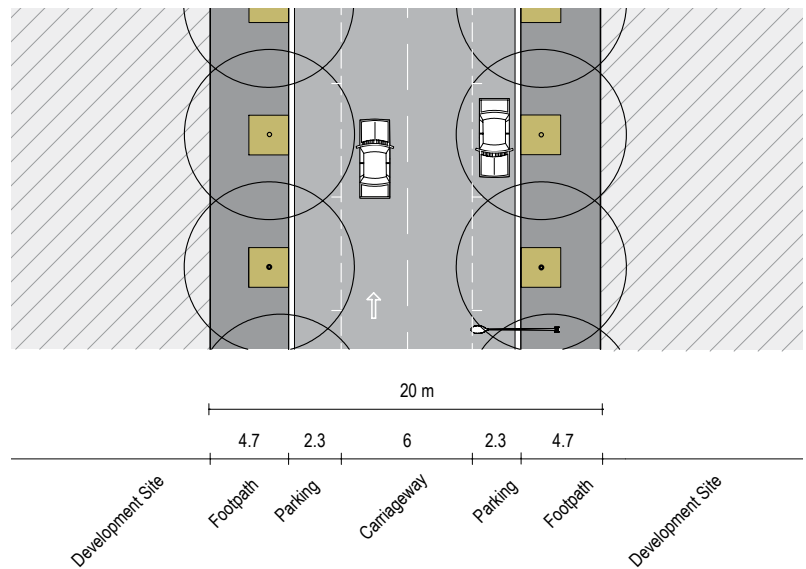

Figure C21b East West Street – Indicative Plan



## S20 Figtree Avenue & Parkview Drive

For arrangement and urban elements refer to the following details:

- 2.1 Placement and Co-ordination**  
PCb for urban element placement
- 3.1 Pavements and Level Changes**  
P12 for footpath paving  
P15 for kerb ramp
- 3.2 Street Furniture**  
no seats  
no bins
- 3.3 Lighting**  
LA3 for street lighting
- 3.4 Engineering Elements**  
E3 for kerb and gutter
- 3.5 Street Tree Planting**  
T1 for planting species  
T3 for tree in verge

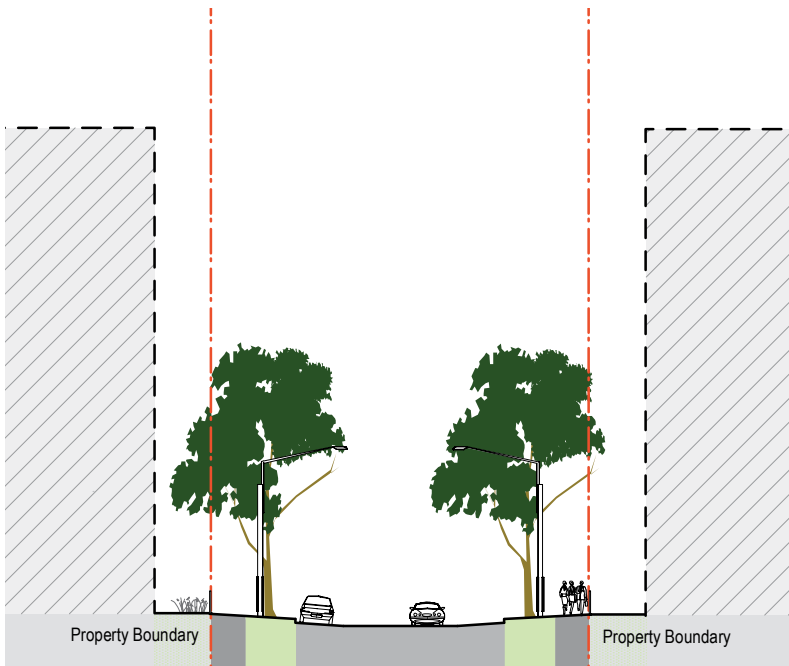
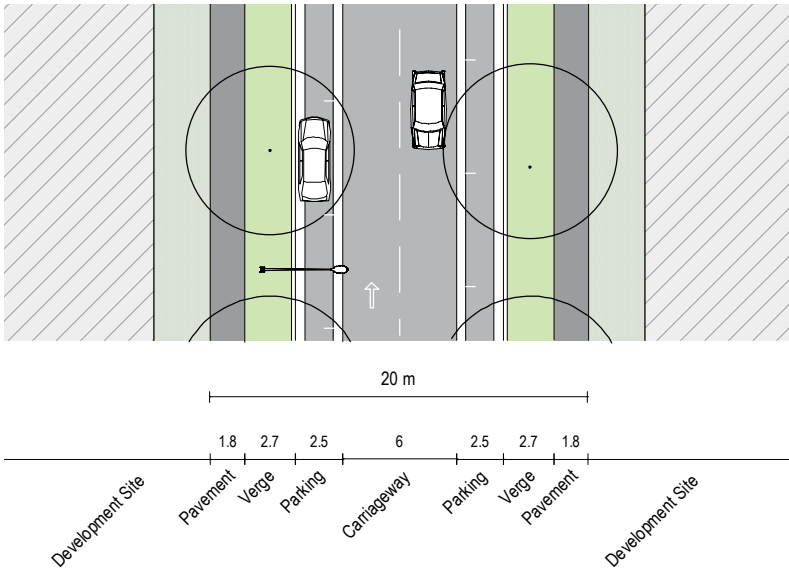

Figure C22b Figtree Avenue & Parkview Drive – Indicative Plan



Principle

2008

DESIGN INTENT ONLY

Section 2.1  
Placement and Co-ordination

S20



## S21A North South Street

For arrangement and urban elements refer to the following details:

- 2.1 Placement and Co-ordination**  
PCb for urban element placement
- 3.1 Pavements and Level Changes**  
P12 for footpath paving  
P15 for kerb ramp
- 3.2 Street Furniture**  
no seats  
no bins
- 3.3 Lighting**  
LA3 for street lighting
- 3.4 Engineering Elements**  
E3 for kerb and gutter
- 3.5 Street Tree Planting**  
T1 for planting species  
T3 for tree in verge

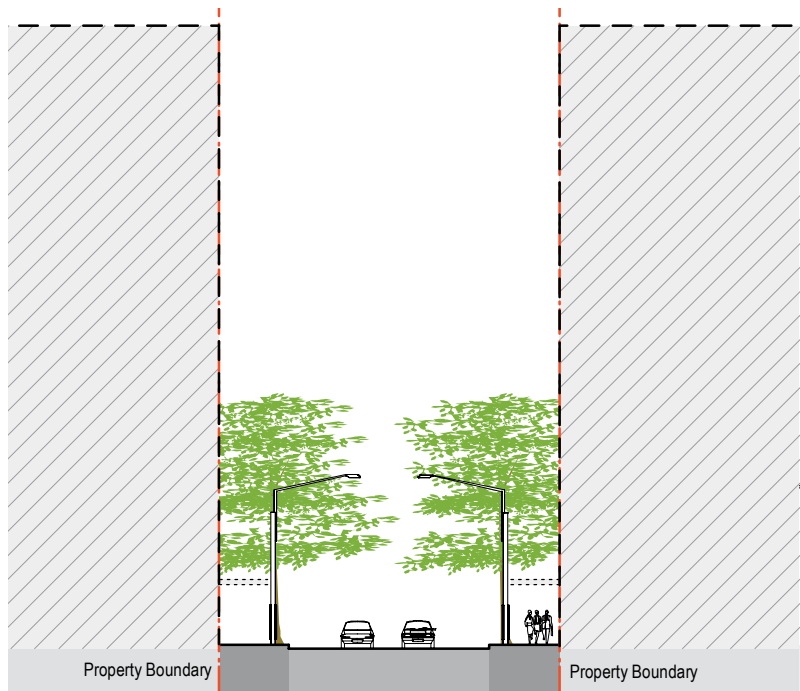
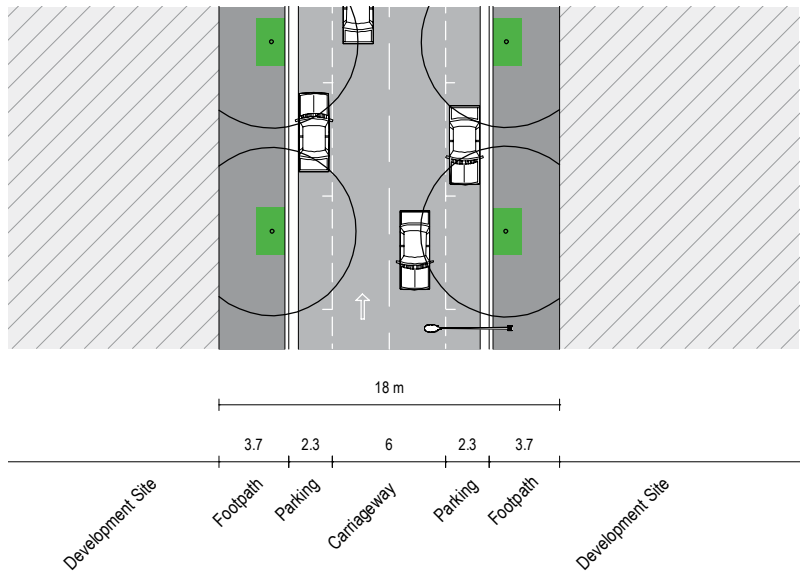

Figure C23b North South Street – Indicative Plan



## S21B Verge Street

For arrangement and urban elements refer to the following details:

- 2.1 Placement and Co-ordination**  
PCb for urban element placement
- 3.1 Pavements and Level Changes**  
P12 for footpath paving  
P15 for kerb ramp
- 3.2 Street Furniture**  
no seats  
no bins
- 3.3 Lighting**  
LA3 for street lighting
- 3.4 Engineering Elements**  
E3 for kerb and gutter
- 3.5 Street Tree Planting**  
T1 for planting species  
T3 for tree in verge

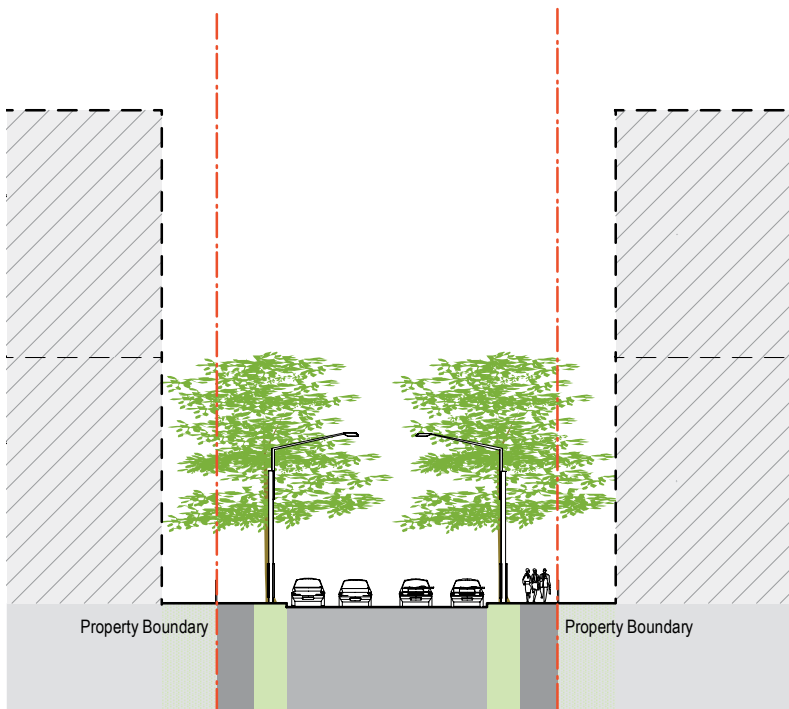
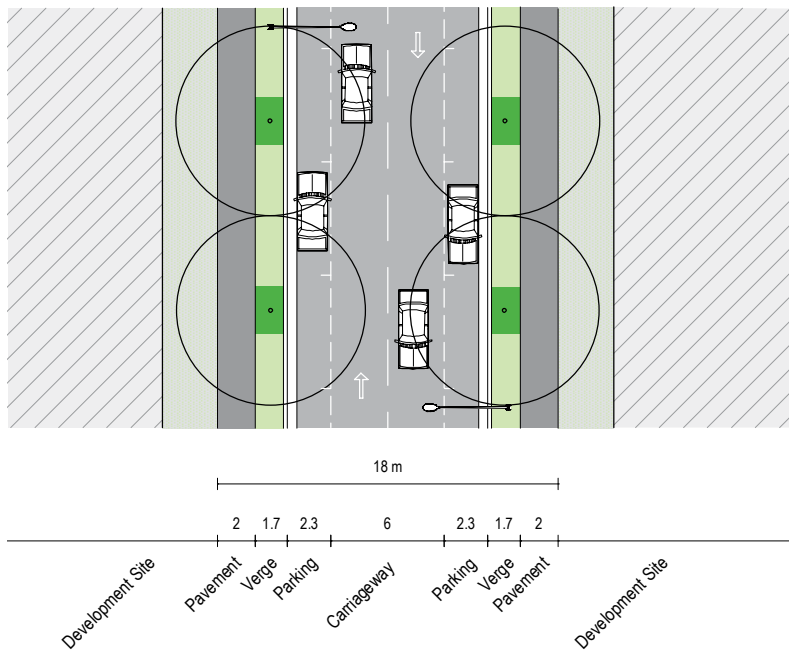

Figure C24b Verge Street – Indicative Plan



## S22 Pedestrian Street

For arrangement and urban elements refer to the following details:

- 2.1 Placement and Co-ordination**  
PCb for urban element placement
- 3.1 Pavements and Level Changes**  
P12 for footpath paving
- 3.2 Street Furniture**  
no seats  
no bins
- 3.3 Lighting**  
LA3 for street lighting
- 3.4 Engineering Elements**  
no kerb and gutter
- 3.5 Street Tree Planting**  
T1 for planting species  
T3 for tree in verge

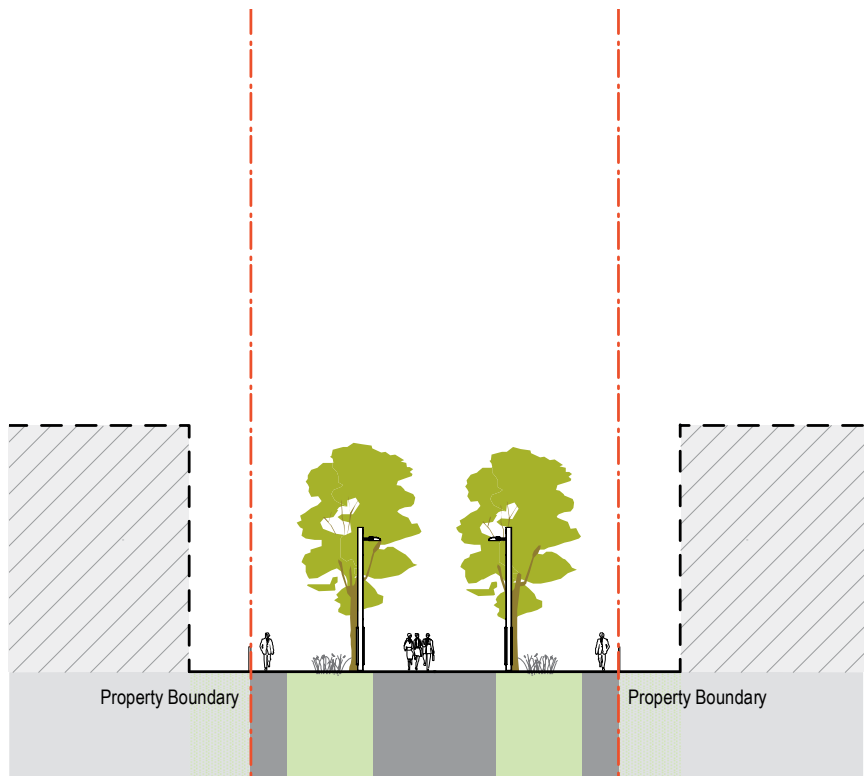
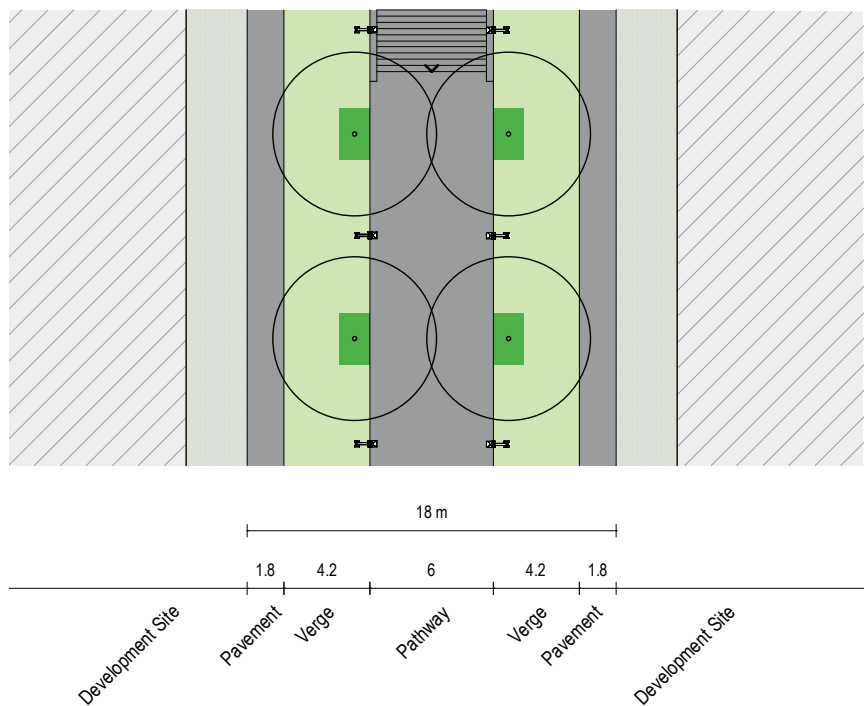

Figure C25b Pedestrian Street – Indicative Plan



## S23 Shared Way

For arrangement and urban elements refer to the following details:

- 2.1 Placement and Co-ordination**  
PCa for urban element placement
- 3.1 Pavements and Level Changes**  
P10 for paving  
no kerb ramp
- 3.2 Street Furniture**  
no seats  
no bins  
SFo7 for removable bollard  
SFo8 for bollard
- 3.3 Lighting**  
LA3 for street lighting
- 3.4 Engineering Elements**  
E5 for swale
- 3.5 Street Tree Planting**  
no planting

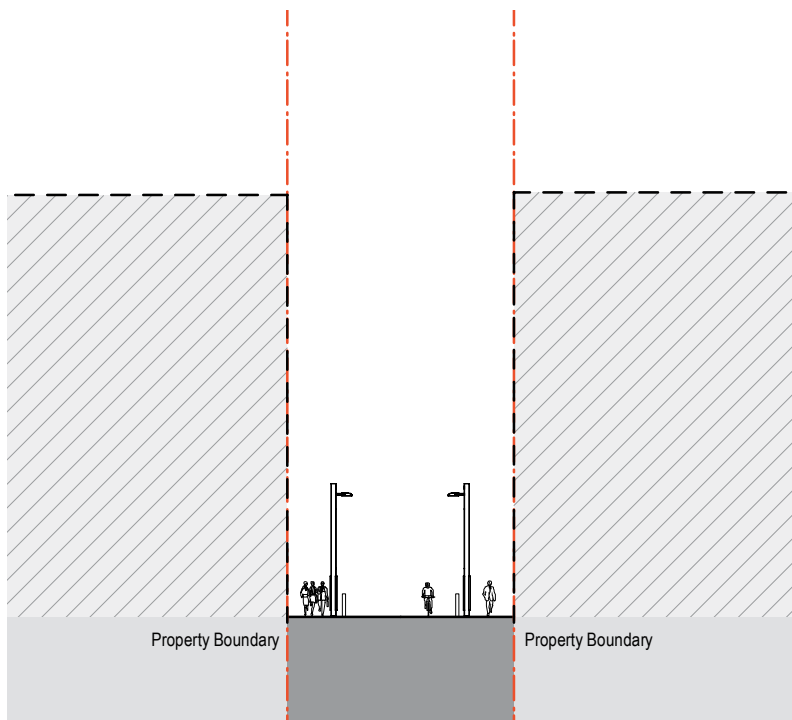
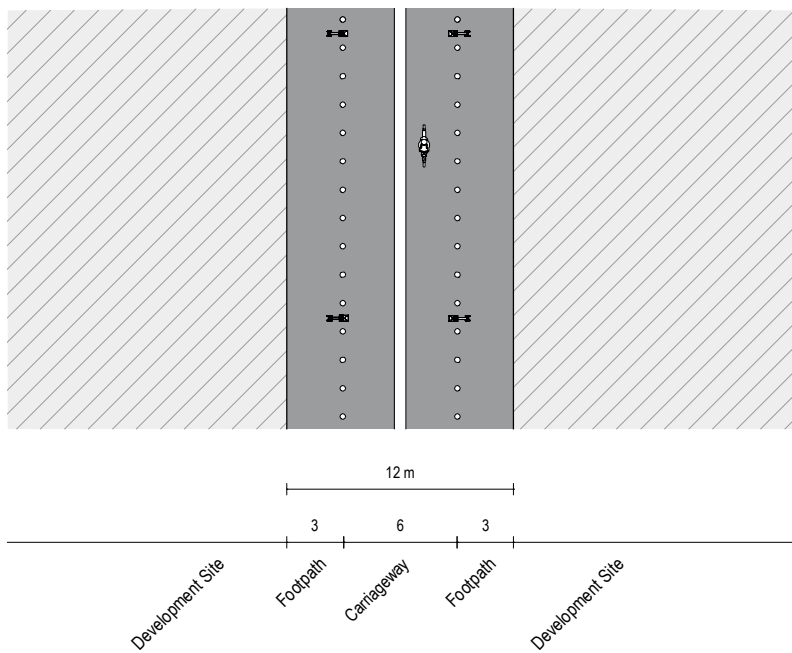

Figure C26b Shared Way – Indicative Plan



Principle	2008	DESIGN INTENT ONLY
	Section 2.1 Placement and Co-ordination	<h1>S23</h1>

## S24 Car Parking Street

For arrangement and urban elements refer to the following details:

- 2.1 Placement and Co-ordination**  
PCa for urban element placement
- 3.1 Pavements and Level Changes**  
P11 for footpath pavement  
P15 for kerb ramp
- 3.2 Street Furniture**  
no seats  
no bins
- 3.3 Lighting**  
LA3 for street lighting
- 3.4 Engineering Elements**  
E3 for kerb and gutter  
E7 for permeable kerb to planting area
- 3.5 Street Tree Planting**  
T1 for planting species  
T4 for tree planting

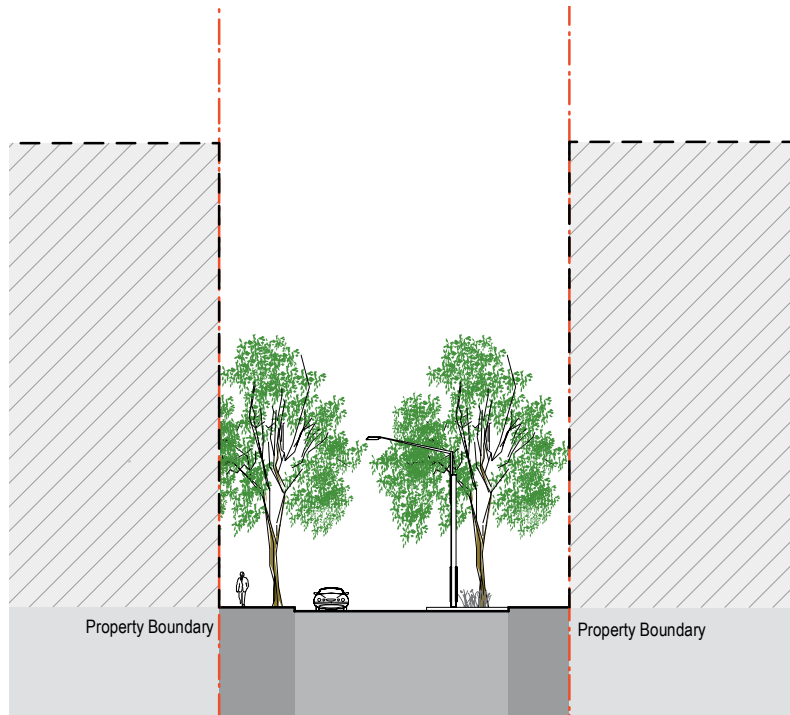
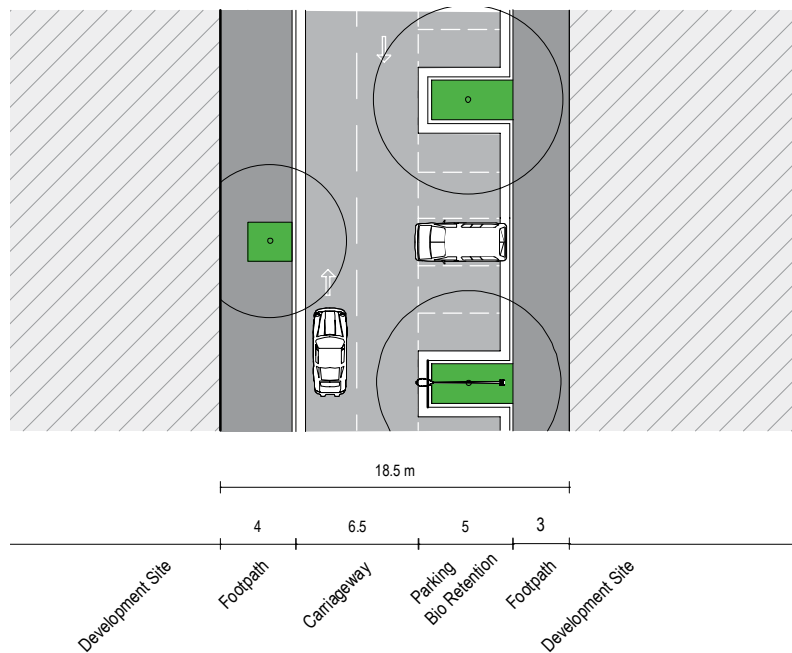

Figure C27b Car Parking Street – Indicative Plan



## S25 Coach Parking Street

For arrangement and urban elements refer to the following details:

- 2.1 Placement and Co-ordination**
  - PCa for urban element placement
  - PCb for urban element placement
- 3.1 Pavements and Level Changes**
  - P12 for footpath paving
  - P15 for kerb ramp
- 3.2 Street Furniture**
  - no seats
  - no bins
  - SF10 for tree grate in footpath
- 3.3 Lighting**
  - LA3 for street lighting
- 3.4 Engineering Elements**
  - E3 for kerb and gutter
- 3.5 Street Tree Planting**
  - T1 for planting species
  - T3 for tree in verge
  - T5 for tree in footpath

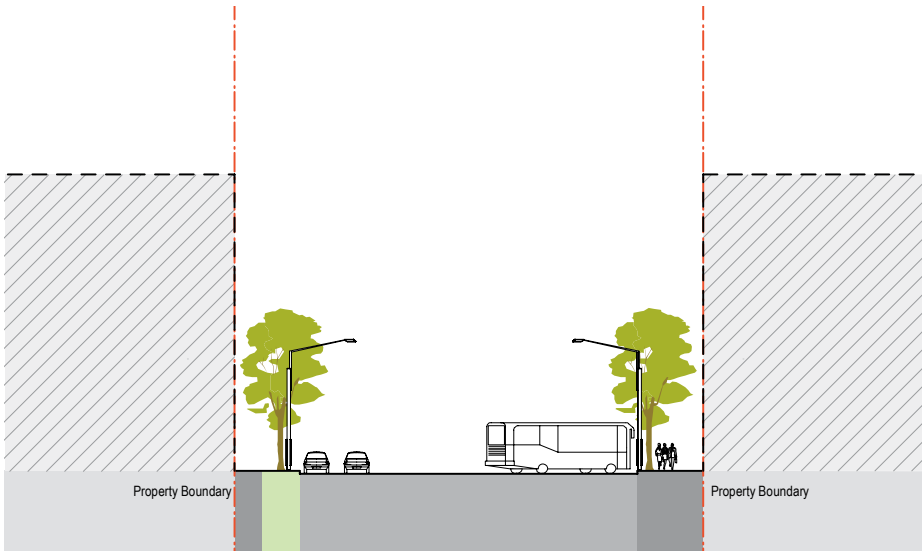
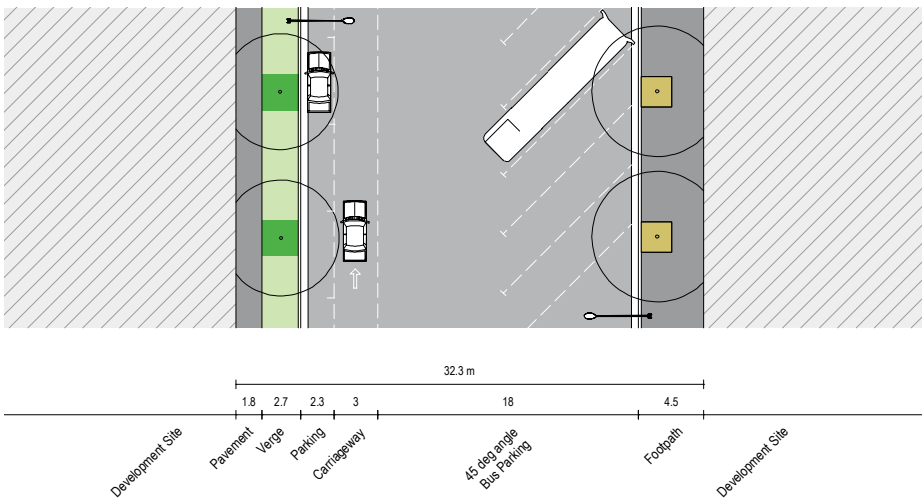

Figure C28b Coach Parking Street – Indicative Plan



Principle	2008	DESIGN INTENT ONLY
	Section 2.1 Placement and Co-ordination	<h1>S25</h1>

## S26 Park Street

For arrangement and urban elements refer to the following details:

### 3.1 Pavements and Level Changes

- P12 for footpath paving
- P15 for kerb ramp

### 3.2 Street Furniture

- no seats
- no bins

### 3.3 Lighting

- LA3 for street lighting

### 3.4 Engineering Elements

- E3 for kerb and gutter

### 3.5 Street Tree Planting

- T1 for planting species

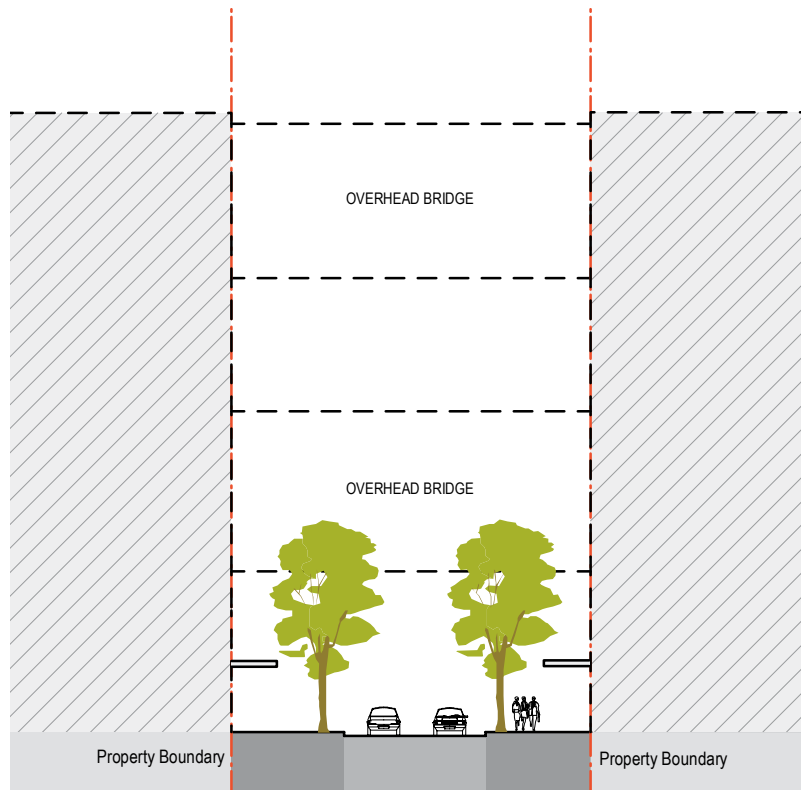
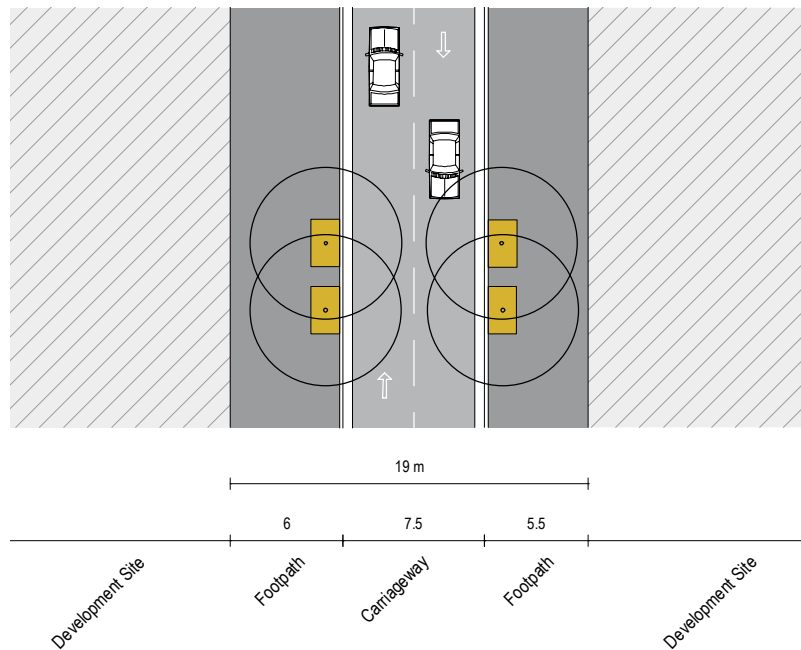

Figure C29b Park Street – Indicative Plan



### S27 Showground Street

For arrangement and urban elements refer to the following details:

- 3.1 Pavements and Level Changes**  
P12 for footpath paving
- 3.2 Street Furniture**  
no bin  
no seats
- 3.3 Lighting**  
LA3 for street lighting
- 3.4 Engineering Elements**  
no kerb and gutter
- 3.4 Street Tree Planting**  
T1 for planting species



Figure C3ob Showground Street – Indicative Plan

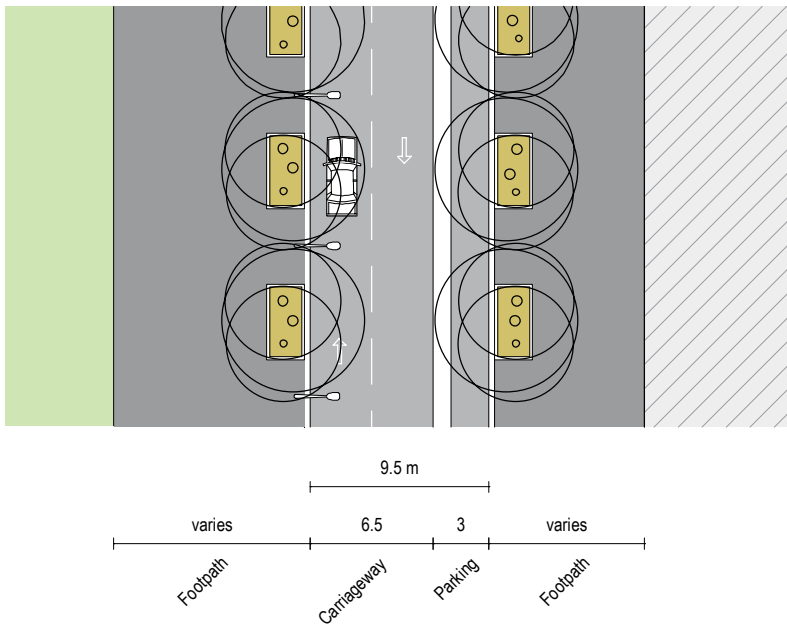



## S28 Bennelong Parkway

For arrangement and urban elements refer to the following details:

### 3.1 Pavements and Level Changes

- P12 for footpath paving
- P15 for kerb ramp

### 3.2 Street Furniture

- SF02 for seats
- SF24 for bins

### 3.3 Lighting

- LA3 for street lighting

### 3.4 Engineering Elements

- E3 for kerb and gutter

### 3.5 Street Tree Planting

- T1 for planting species



Figure C31b Bennelong Road – Indicative Plan

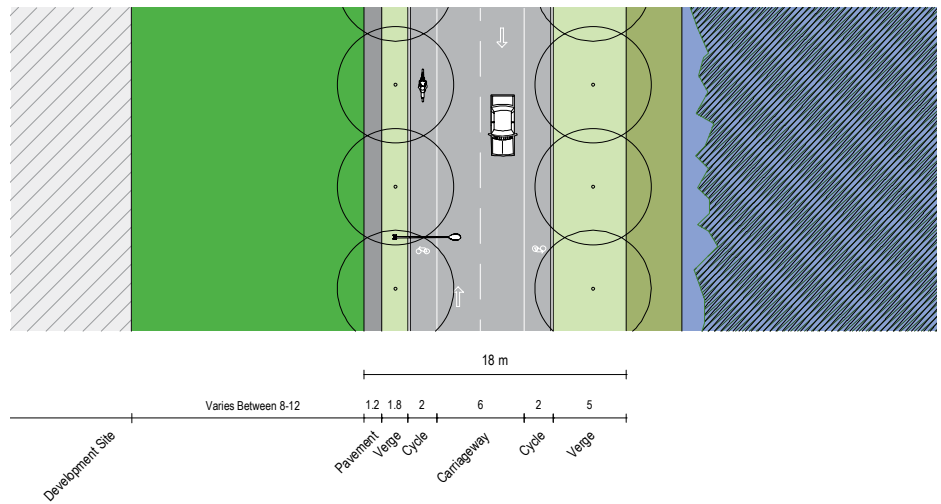

## S29 Marjorie Jackson Parkway

For arrangement and urban elements refer to the following details:

- 3.1 Pavements and Level Changes**
  - P12 for footpath paving
  - P15 for kerb ramp
- 3.2 Street Furniture**
  - SF02 for seats
  - SF24 for bins
- 3.3 Lighting**
  - LA3 for street lighting
- 3.4 Engineering Elements**
  - E3 for kerb and gutter
- 3.5 Street Tree Planting**
  - T1 for planting species



Figure C32b Marjorie Jackson Parkway – Indicative Plan

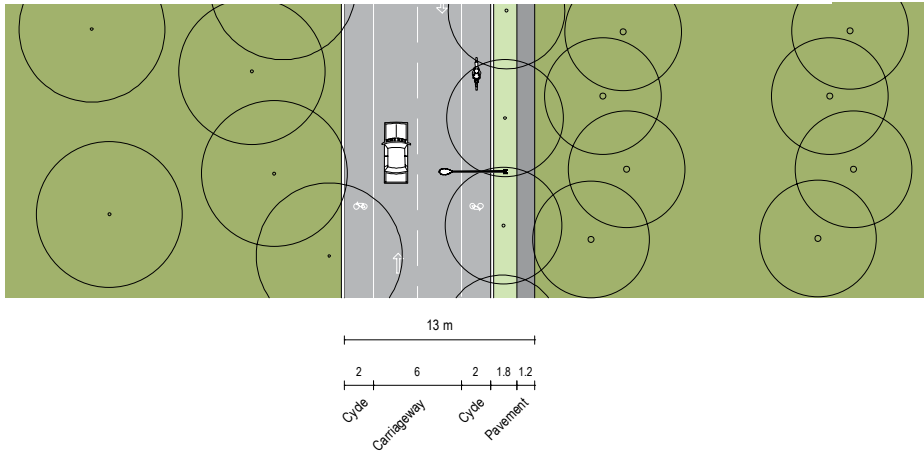

### S30 Shirley Strickland Avenue

For arrangement and urban elements refer to the following details:

- 3.1 Pavements and Level Changes**
  - P12 for footpath paving
  - P15 for kerb ramp
- 3.2 Street Furniture**
  - SF02 for seats
  - SF24 for bins
- 3.3 Lighting**
  - LA3 for street lighting
- 3.1 Engineering Elements**
  - E3 for kerb and gutter
- 3.5 Street Tree Planting**
  - T1 for planting species

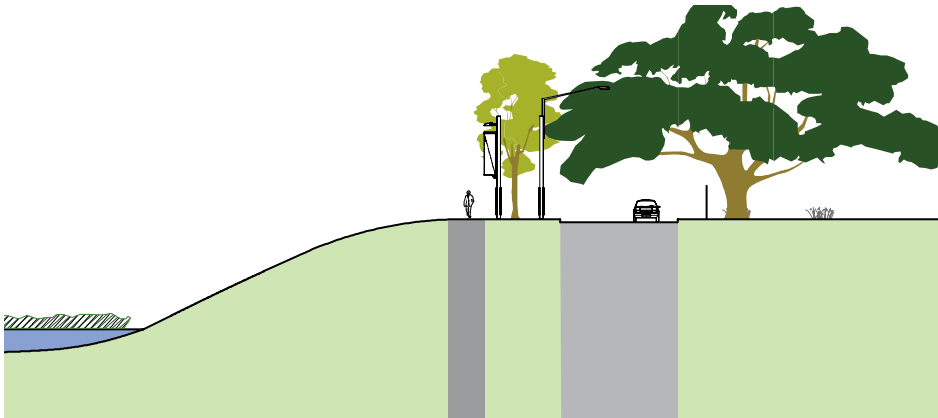
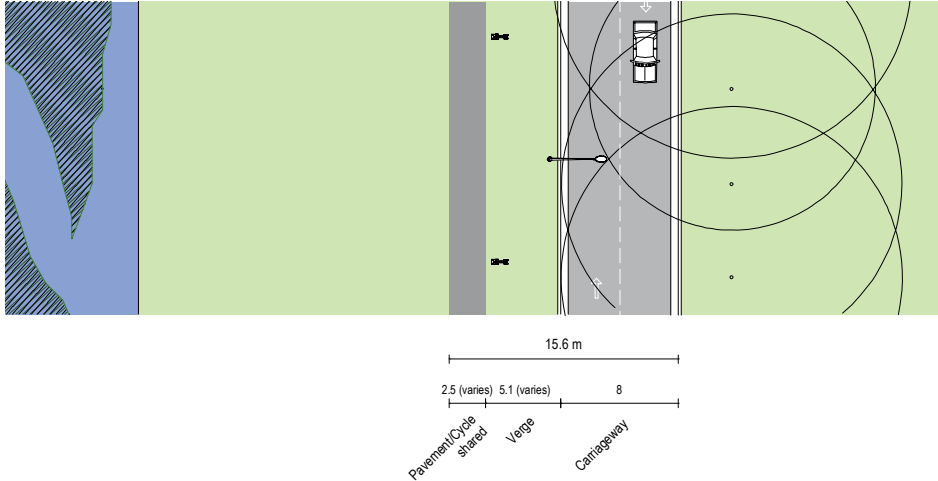

Figure C33b Shirley Strickland Avenue – Indicative Plan



### S31 Park Edge Street Haslams

For arrangement and urban elements refer to the following details:

- 2.1 Placement and Co-ordination**
  - PCb for urban element placement
  - PCc for urban element placement
- 3.1 Pavements and Level Changes**
  - P12 for footpath paving
  - P15 for kerb ramp
- 3.2 Street Furniture**
  - SFO2 for seats
- 3.3 Lighting**
  - LA3 for street lighting
- 3.4 Engineering Elements**
  - E3 for kerb and gutter
- 3.5 Street Tree Planting**
  - T1 for planting species
  - T3 for tree in verge



Figure C34b Park Edge Street Haslams – Indicative Plan

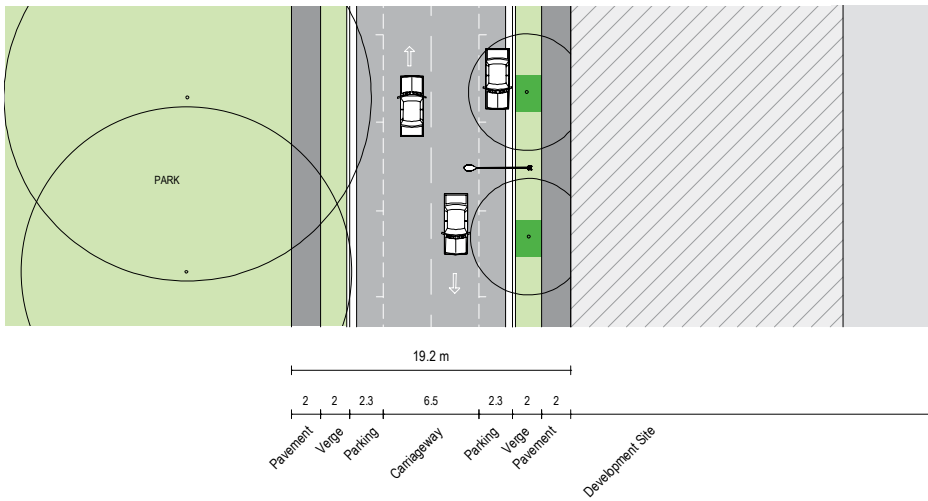

## S32 Park Edge Street Boundary Creek

For arrangement and urban elements refer to the following details:

- 2.1 Placement and Co-ordination**
  - PCb for urban element placement
  - PCc for urban element placement
- 3.1 Pavements and Level Changes**
  - P12 for footpath paving
  - P15 for kerb ramp
- 3.2 Street Furniture**
  - SFo2 for seats
- 3.3 Lighting**
  - LA3 for street lighting
- 3.4 Engineering Elements**
  - E3 for kerb and gutter
- 3.5 Street Tree Planting**
  - T1 for planting species
  - T3 for tree in verge

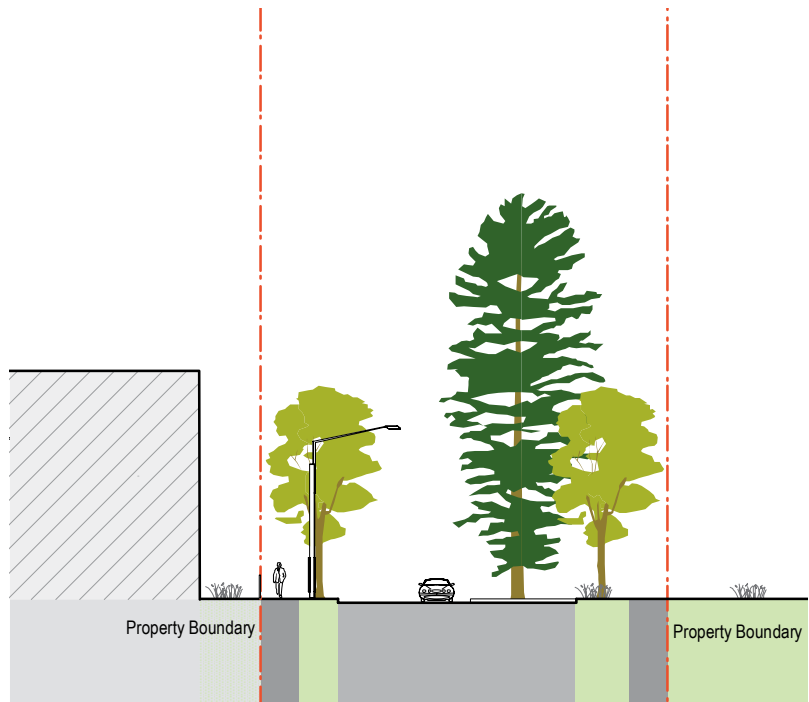
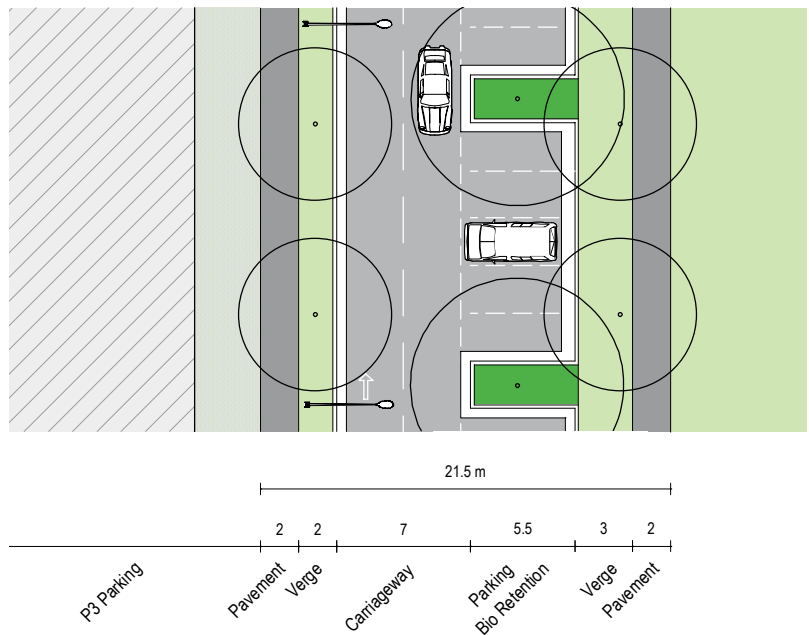

Figure C35b Park Edge Street Boundary Creek – Indicative Plan



### S33 Rod Laver Drive

For arrangement and urban elements refer to the following details:

- 2.1 Placement and Co-ordination**
  - PCb for urban element placement
  - PCc for urban element placement
- 3.1 Pavements and Level Changes**
  - P12 for footpath paving
  - P15 for kerb ramp
- 3.2 Street Furniture**
  - SFO2 for seats
- 3.3 Lighting**
  - LA3 for street lighting
- 3.4 Engineering Elements**
  - E3 for kerb and gutter
  - E7 for permeable kerb to planting area
- 3.5 Street Tree Planting**
  - T1 for planting species
  - T3 for tree in verge
  - T4 for tree planting



Figure C36b Rod Laver Drive – Indicative Plan

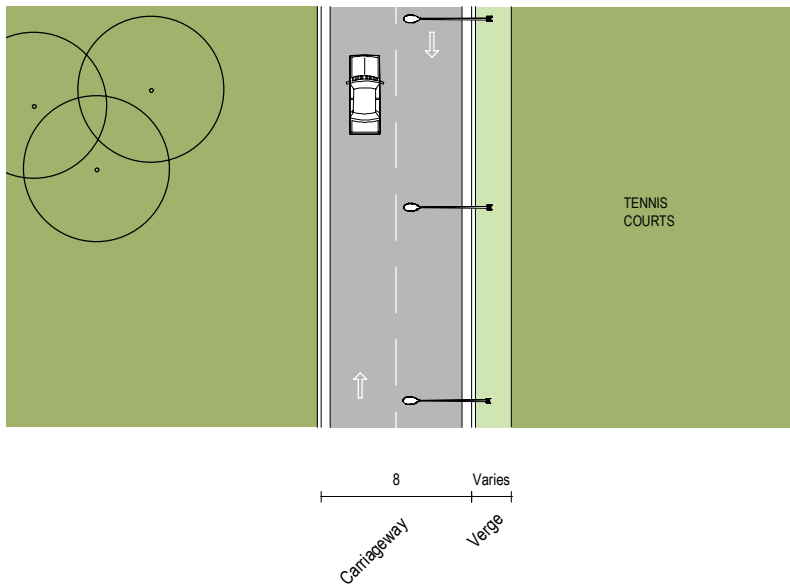



Placement and Co-ordination

# Intersection Arrangement

Urban Elements Design Manual  
Section

# 2.2

ISBN 978-0-9805976-1-5

© All rights reserved. No part of this work will be reproduced, translated, modified, transmitted or stored in any form by any means without the prior permission of Sydney Olympic Park Authority.



## 2.2 Intersections

Well designed intersections reinforce the street hierarchy and are essential for pedestrian amenity and safety. The following principles apply to intersections generally throughout Sydney Olympic Park:

- pedestrian amenity and urban design principles are to be considered as leading requirements, with traffic requirements taken into consideration;
- larger, more important streets take precedence at intersections for placement of urban elements;
- standard kerb radii of 3, 5 and 7m are to be applied: minimum kerb radii dimensions are to be selected to accommodate traffic requirements;
- kerb ramps are to align across the street in accordance with AS1428 requirements and UEDM detail;
- street lights are generally to be located within 10m of new intersections;
- placement of urban elements are to comply with sight line requirements identified by the traffic engineer;
- arrangement of kerb radii at intersections is subject to final design by the traffic engineer;
- lighting arrangement is subject to final design by lighting consultant;
- final arrangement of urban elements is subject to final intersection design; and
- regulatory signs and line marking are subject to final engineering design.

### Intersection Principles

The following principles are to apply in order of priority:

- place kerb ramps in larger street in accordance with AS1428 requirements – generally align the edge of the ramp with the edge of footpath or building;
- place kerb ramps in smaller streets on required alignment – where there is insufficient room to achieve the above, align edge of ramp with tangent point of intersection curve;
- align pavement edge at kerb return to meet kerb at 90 degrees;
- place street lights in centre of verge for longitudinal alignment;
- place street name sign on light pole;
- place street lights at intersections 1m from edge of pavement or edge of kerb ramp;
- place street trees at intersection 10m from face of kerb (FOK) of intersecting street; and
- place street lights centrally between street trees, ensure minimum clearance of 3m between street tree and street light.

Placement and Co-ordination

# Urban Elements Arrangement

Urban Elements Design Manual  
Section

# 2.3

ISBN 978-0-9805976-1-5

© All rights reserved. No part of this work will be reproduced, translated, modified, transmitted or stored in any form by any means without the prior permission of Sydney Olympic Park Authority.

## 2.3 Location of Street Furniture and Trees in Footpaths

### Introduction

The location of urban elements is an important feature of well designed streets. The elements are to be inserted into the pavement as seamlessly as possible and located to reinforce the general streetscape design. Following are three examples of typical arrangements for street furniture within the typical footpaths. Urban elements are to be located in accordance with these diagrams and the following principles:

- incorporate required setbacks from the kerb;
- provide required clear paths of travel including required paths for equal access;
- incorporate specific requirements for different elements in the following hierarchy;
  1. lights
  2. trees
  3. other street furniture
- group street furniture together in simple compositions as shown; and
- ensure groups of elements are well sequenced along the street.

**Typical Street Furniture Placement:**

**Fully Paved Footpath**

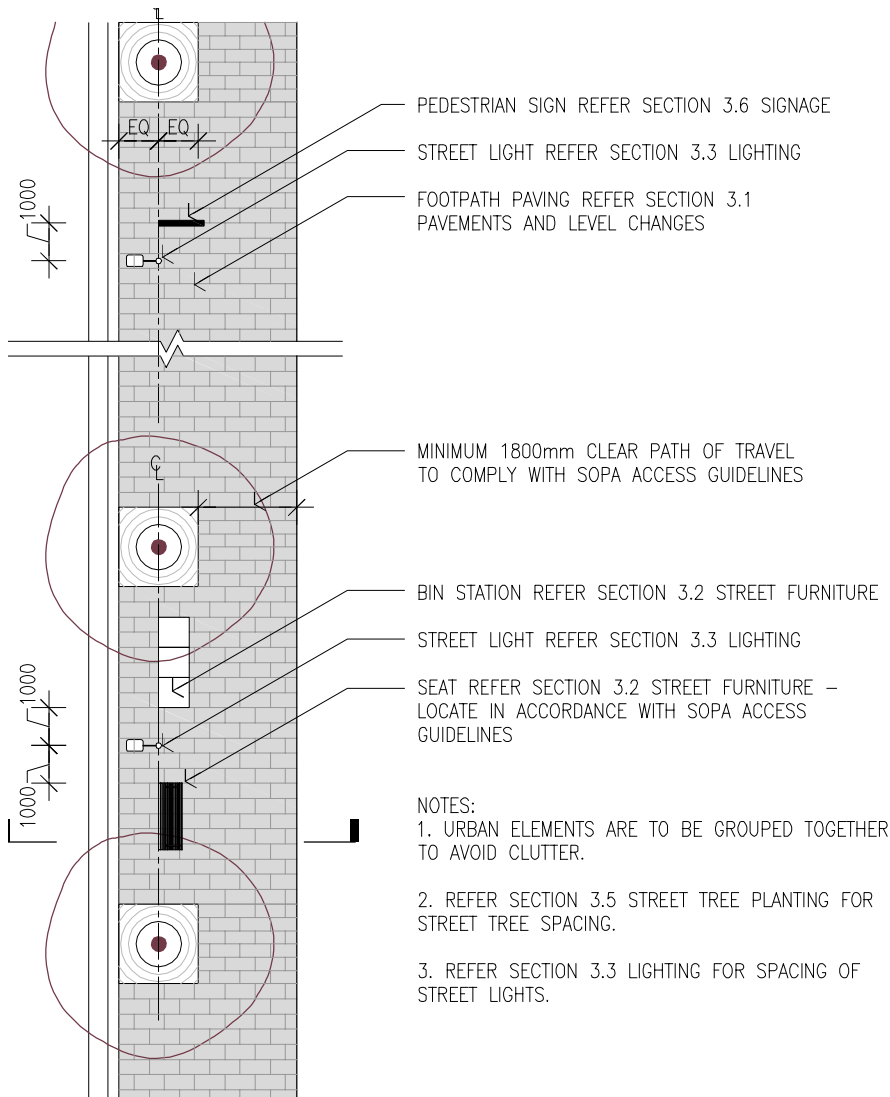

PLAN

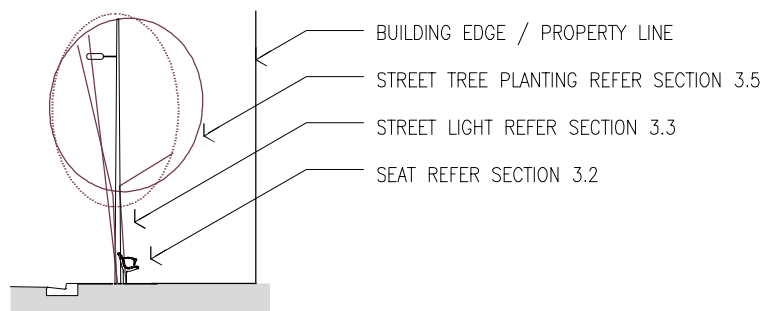

SECTION

Typical Street Furniture Placement:

Pavement and Verge Footpath

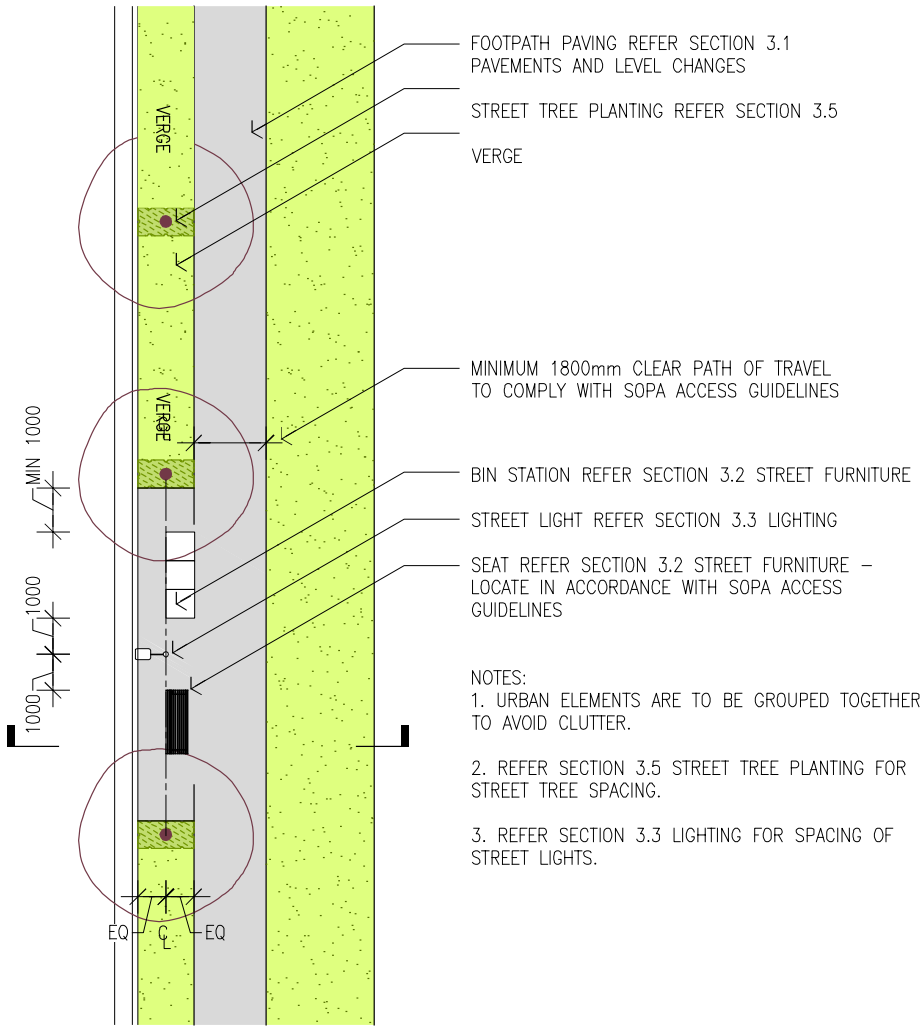

PLAN

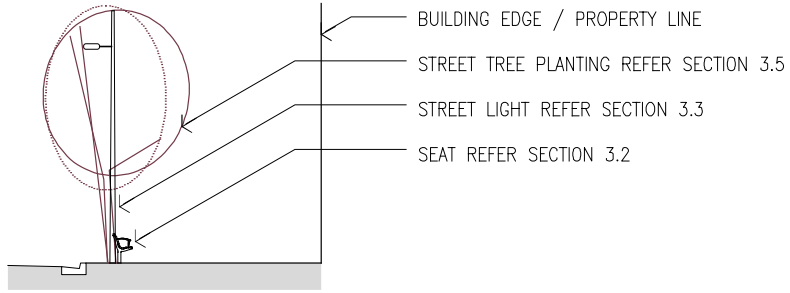

SECTION

**Typical Street Furniture Placement:**

**Footpaths within Parks**

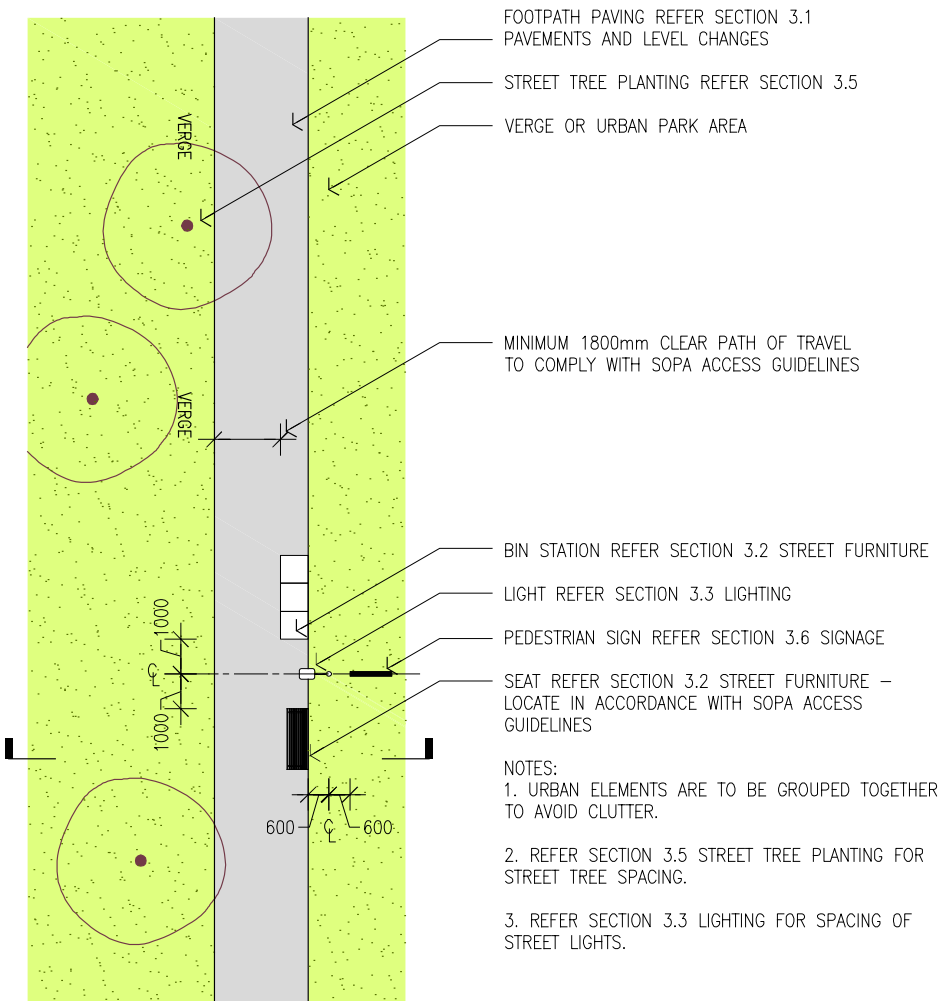

PLAN

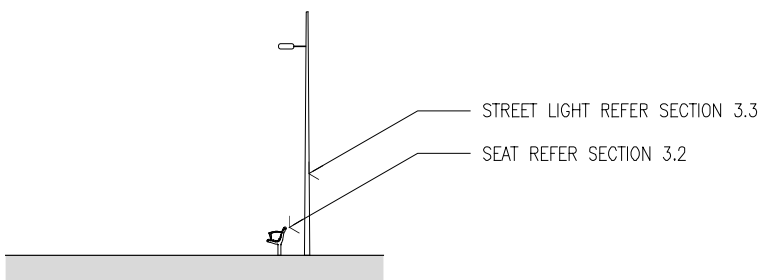

SECTION

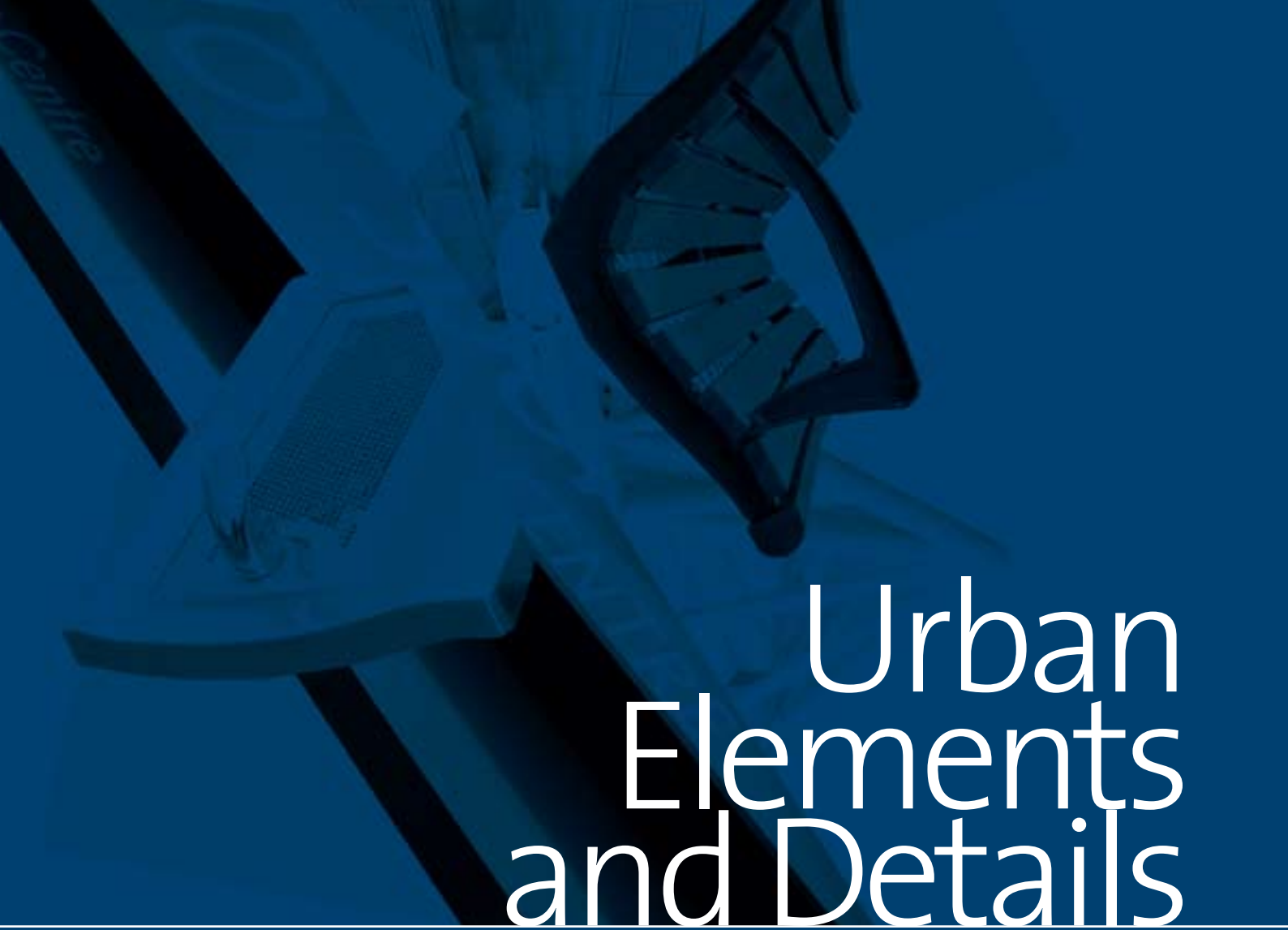

# Urban Elements and Details

Urban Elements Design Manual  
Section

# 3.0

ISBN 978-0-9805976-1-5

© All rights reserved. No part of this work will be reproduced, translated, modified, transmitted or stored in any form by any means without the prior permission of Sydney Olympic Park Authority.

## 3.0 Introduction

This section schedules urban elements: paving, level changes, lighting, street trees, signage and street furniture. In addition, there are some larger, special items such as the Plaza Pylons. All items demonstrate a consistent approach to design, material selection, finish, access and placement and are conceived as a co-ordinated suite of elements that contribute to the character and identity to Sydney Olympic Park.

The Urban Elements reflect the unique scale, development history and climate of Sydney Olympic Park. They also respond to a wide range of functional requirements including special events, accessibility, large crowd movements, operations and maintenance as well as temporary overlays, including communications and power outlets and “party decorations”.

Equal access issues for all users during both heavy crowd flows and the everyday mode has been provided, to ensure an appropriate level of amenity for all visitors.

The urban elements and their components have been assessed environmentally, a process that has offered a systematic approach to decision making based upon understanding of the environmental attributes associated with each element.

The paving follows the streets master plan hierarchy. The robust detailing and large-scale banding within the core will define a dramatic and recognisable Sydney Olympic Park image that is linked to the detail of the other elements. Accessibility has been a primary consideration in the detailing of pavements, kerbs and their finishes.

The lighting strategy incorporates standard light fittings on purpose-designed poles in the existing areas and off the shelf poles in newer local streets. The purpose designed poles are simple constructions specifically designed to accept the special demands of the Sydney Olympic Park site, reinforcing the scale and character of the overall site. The ready made poles are finer in the smaller streets and meet newer frangibility requirements.

The street furniture combines a number of standard manufactured items with some purpose designed elements. Each has been selected to ensure its place within the system.

Signage is developed in the same simple and distinctive design language.

The signs are crucial for the site, both functionally and as a major determinant of site image. Dynamic and fixed signs combine with the Way finding Strategy to produce a complete system.

The following sample page demonstrates the information layout for each urban element which includes its specification, a photograph, scaled drawings and a key to the locations where it is used.



Sample Page

Image of element.

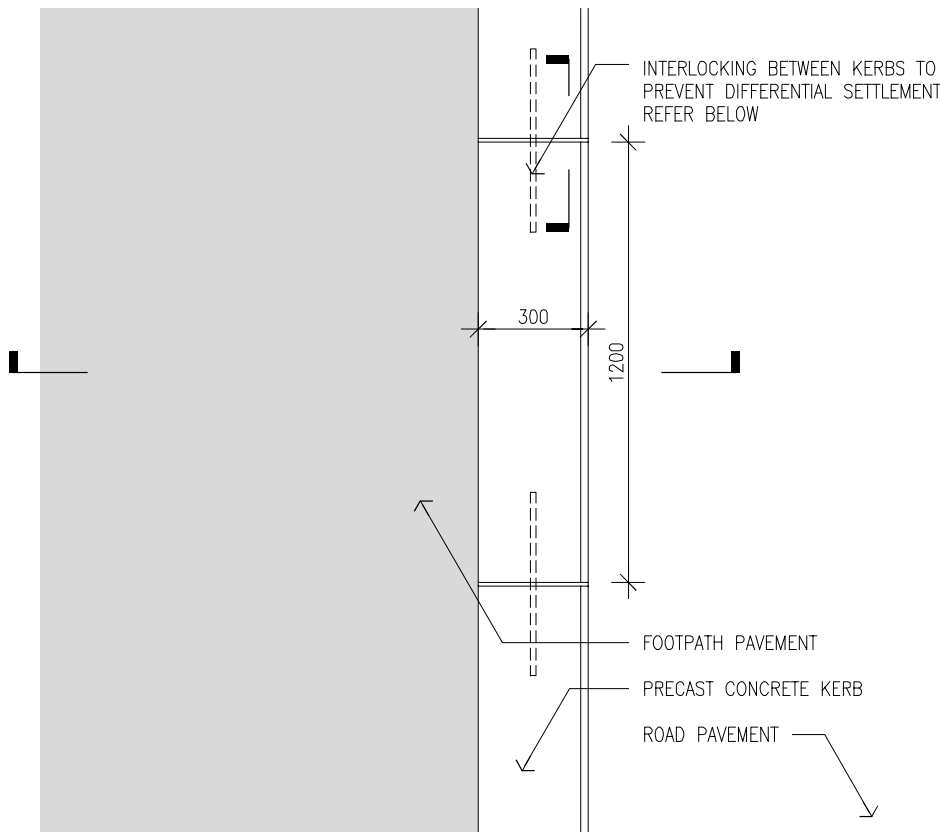

Material

- Precast concrete kerb 300mm width x 1200mm length.

Composition

- Strength – 20MPa.
- Large aggregate – Marrangaroo gravel or similar.
- Fine aggregate – washed river sand.
- Off-white cement.

Finish

- Acid etch finish.

Construction

- To engineers final specification.
- Placement and installation of kerbs to manufacturers specification.
- Recycled base material to engineers final specification.

Information about materials, finishes, construction and special requirements.

Street Type where detail is used: refer detail MP for street names and locations. Colours show street hierarchy refer detail MP. (AR=As Required)

S1	S2	AR
----	----	----

Principle for use of detail.

Revision status.

<b>Principle</b>	<b>2008</b>	<b>DESIGN INTENT ONLY</b>
High quality finish for use in Civic Streets.	<b>Section 3.0</b> Urban Elements and Details	Detail number. <span style="font-size: 2em; font-weight: bold; color: white;">E1</span>



# Pavements and Level Changes

Urban Elements Design Manual

Section

# 3.1

ISBN 978-0-9805976-1-5

© All rights reserved. No part of this work will be reproduced, translated, modified, transmitted or stored in any form by any means without the prior permission of Sydney Olympic Park Authority.

## 3.1 Pavements and Level Changes

### Introduction

Footpaths and pavements of public spaces are unifying elements in the public domain, where buildings, signs, objects, people and movement provide constant variation and change. They are to give clear expression of pedestrian priority. A co-ordinated and appropriate palette of paving materials is necessary to achieve this, as is continuity of footpath dimensions, levels, materials and edges. At Sydney Olympic Park, the different paving materials are unified by a harmonious colour palette and continuity of detailing, including kerbs and kerb ramps.

### Objectives

The selection and detailing of paving materials at Sydney Olympic Park is designed to achieve the following objectives:

- visually co-ordinate the public domain;
- create a continuous ground plane upon which people, buildings and movement provide variation and change;
- provide legibility of different paving types;
- clearly delineate pedestrian and vehicular zones;
- use a minimal and consistent palette of materials;
- achieve environmental principles adopted for the site; and
- minimise the life cycle costs and maintenance requirements.

### Existing Paving

Major public spaces and streets, created for the Games are paved in concrete interlocking pavers in dynamic patterns and colours. Other existing streets are paved in asphalt with wider 300mm kerbs in larger streets and standard 180mm wide kerbs in smaller connecting streets. Some older streets in the Royal Agricultural Society precinct are paved in washed aggregate concrete.

The existing avenue streets have generous footpaths which are partially paved and partially planted with grass verges. This established character of materials and detailing, is robust, pragmatic and functional and reflects the hierarchy and use of streets and public spaces in a clear and legible way.

### Paving for UEDM

The street hierarchy described in Streets Master Plan provides the framework for the hierarchy of paving materials of interlocking concrete pavers, asphalt and grass verges. A new type, large format paver, has been introduced for the new main streets with township uses and high pedestrian volumes. Where pedestrian volumes allow, grass verges have been used in footpaths in the proposed new streets as they reduce runoff and provide greater soil volumes to support better tree growth and health. The main pavement types are shown in the pavement plan PT and described on the following page.

### Procurement

Procurement of urban elements must comply with the NSW Government's procurement policies.

## Interlocking Paving

Used on the major civic street and public spaces in dynamic colours and patterns. On new extensions to these streets towards the town's edges this paving is coupled with grass verges.

## Large Format Pavers

Large format paved footpaths define important town streets with high pedestrian volumes. Used on Campus Walk and adjoining special parking streets and to repave Herb Elliot Avenue which will become the major retail street in the new town centre.

## Asphalt with Verge

The most common paving type, used throughout the town on new streets. The respective widths of the verges and pavements varies depending on the street's classification. At the park edges the verge is very wide and the path set into the park to allow the street trees and park. On the median streets and perimeter avenues the verge is coupled with a planted median to further emphasise the landscape setting.

## Asphalt

Smaller existing connecting streets in the town centre and in the Royal Agricultural Society Precinct have full asphalt paving.

Washed Aggregate Paving

Existing main streets and spaces in the Showground area have washed aggregate paving.

## Relevant Standards

The paving strategy is to be read in conjunction with the latest edition of all relevant Australian Standards. Where Australian Standard do not exist, appropriate International Standards will apply.

Relevant Australian Standards include but are not limited to the following:

AS 1160	Bituminous emulsions for the construction and maintenance of pavements
AS 1289	Methods of testing soils for engineering purposes

AS 1379	Specification and supply of concrete
AS 1428	Design for access and mobility
AS 2150	Hot mix asphalt – A guide to good practice
AS 2758	Aggregates and rock for engineering purposes
AS 2876	Concrete kerbs and channels (gutters) – Manually or machine placed
AS 2891	Methods of sampling and testing asphalt
AS/NZS 4455	Masonry units and segmental pavers
AS/NZS 4586	Slip resistance classification of new pedestrian surface materials
AS/NZS 4663	Slip resistance measurement of existing pedestrian surfaces
AS ISO 9001	Quality management systems – Requirements
SAA HB197	Introductory Guide to the Slip Resistance of Pedestrian Surface Materials
AS 1428	Design for access and mobility
Other guidance documents include but are not limited to:	
CMAA T45	Concrete Segmental Pavements – Design Guide for Residential Accessways and Roads
NTN DES 001	Slip Resistance

**Footpath Paving Typology**

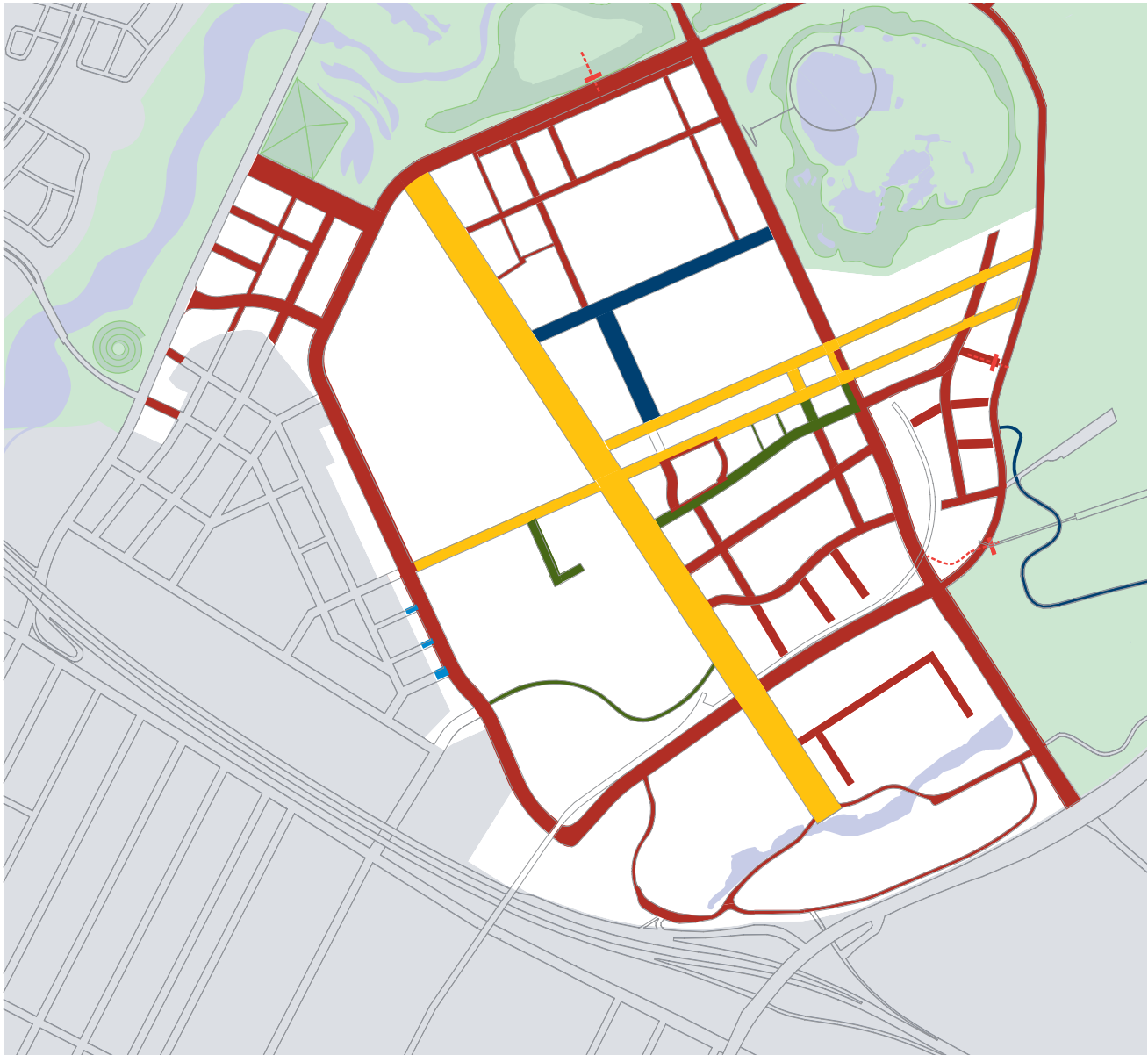

**Footpath Paving Typology**

-  Tri hex and Eco Trihex Interlocking Paving
-  Asphalt Paving
-  Non Interlocking Uni Pave
-  Washed Aggregate Paving
-  Large Format Pavers

### Paving Interface at Intersections

**Construction**

- The larger more important street pavements continue through to kerb at intersection.

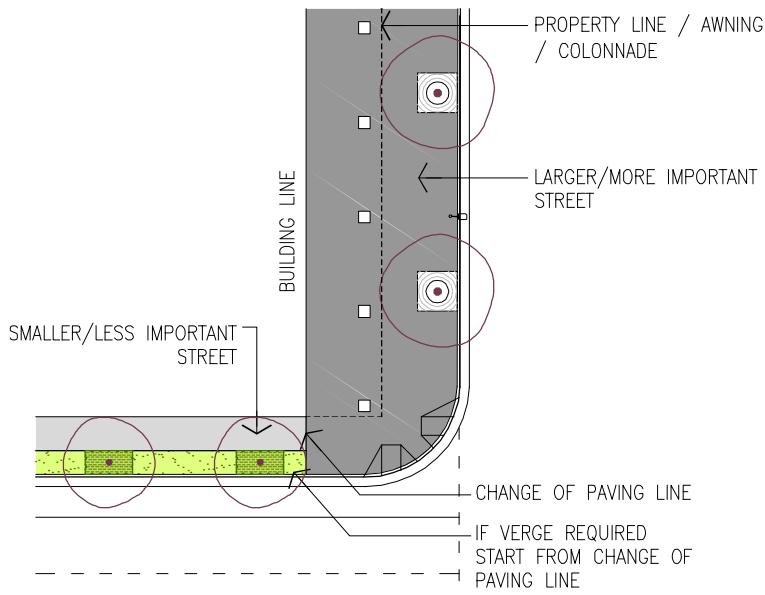

### Building with Awning/Colonnade

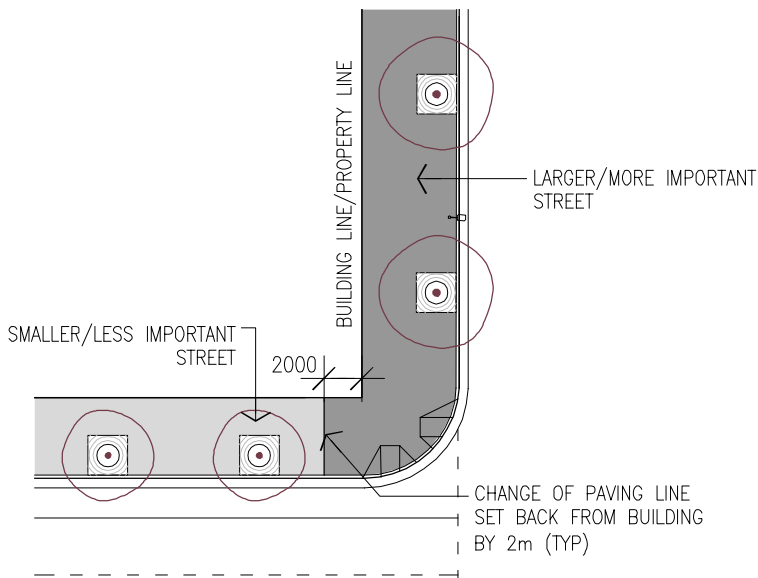

### Building on Property Line

AR

**Principle**

The larger more important street pavements continue through to kerb at intersection.

**2009**

Section 3.1  
Pavements and Level Changes

**DESIGN INTENT ONLY**

## Paving Under Awnings or Colonnades

### Construction

- Avoid level change between footpath and awning/colonnade where ever possible.
- Where there are no level changes the paving type on footpath is to be extended under colonnade or awning to meet building line.
- If level change is unavoidable under awning or colonnade the paving is to be large format (P11).
- Avoid floor level of building being set lower than adjacent footpath where ever possible.
- Stair and ramps to be used where ever practical where a level change occurs to maximise permeability of the public domain.
- Building entry points to be flush with paving level.

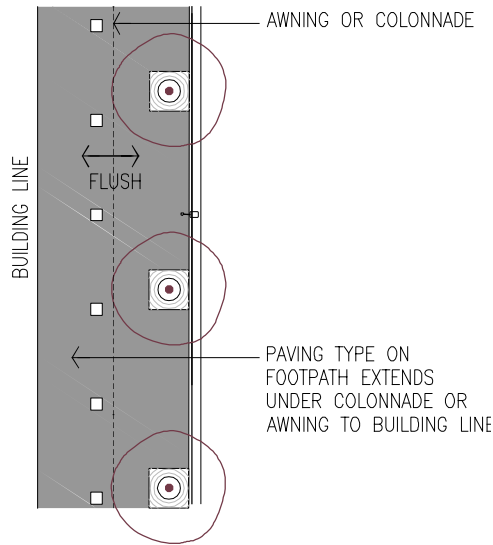

## No Level Change Under Awning or Colonnade

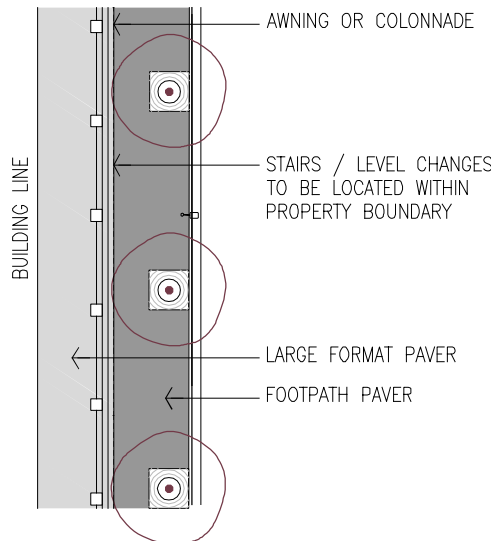

## Level Change Under Awning or Colonnade

AR

This page has been left blank intentionally.



## Paving Direction Change



### Construction

- Paving courses to be 90 degrees to kerb unless otherwise noted.
- Setout pavers is from kerb and cut to building line.
- Saw-cut make-up units must not be less than 30% of the original size.
- Where pavers change direction at an intersection corner, minimise boundary effect of direction change as shown.

### At Angles

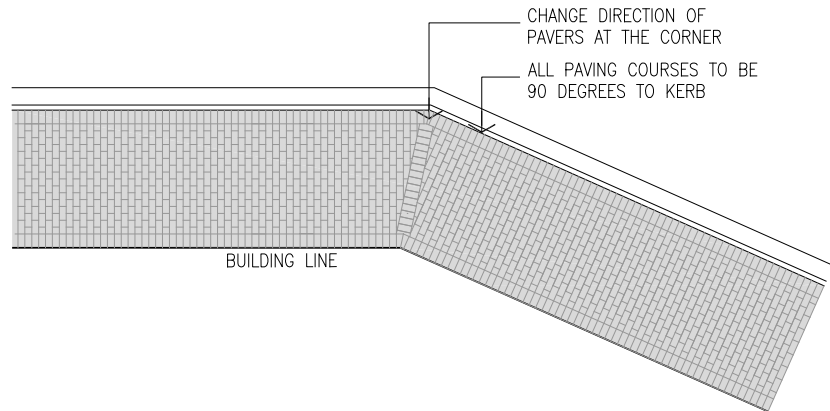

### At Curves

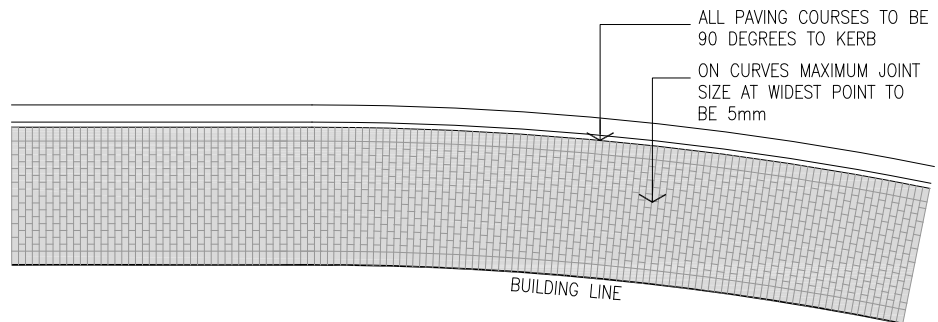

### At 90 Degree Corners

At intersections where same size large format unit pavers are used on both intersecting streets

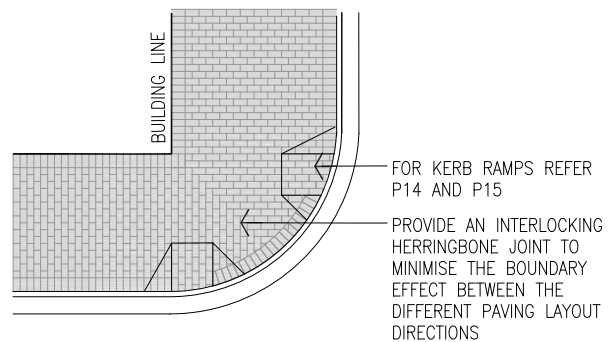

AR

### Insitu Concrete Seat Wall

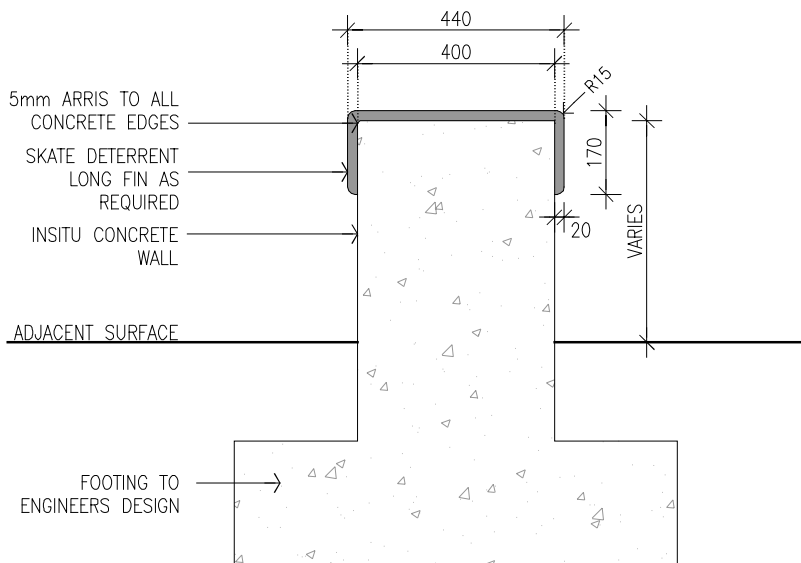

### Insitu Free Standing Concrete Seat Wall

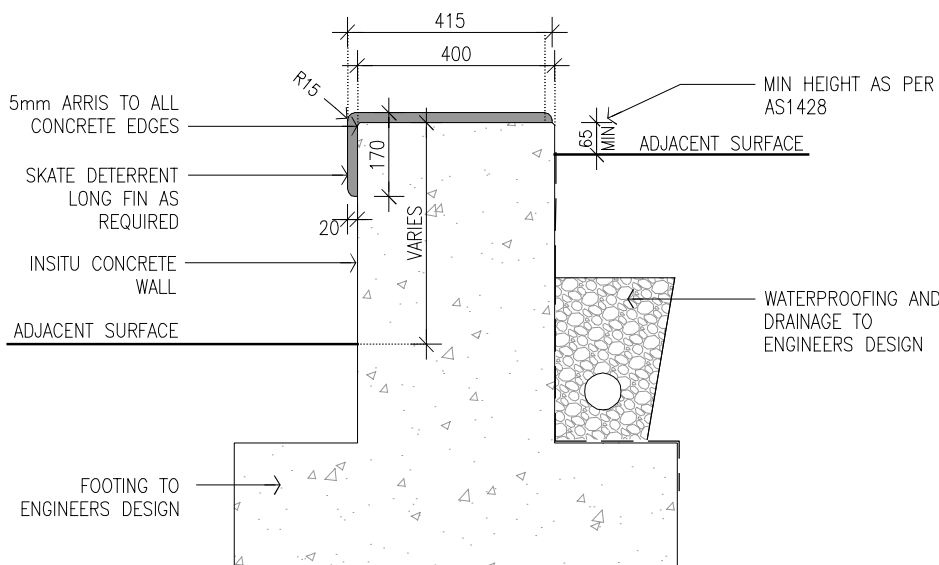

#### Material/Finish

- Insitu concrete wall class 2 finish.
- Colour – off white (colour sample to be approved by sopa).
- Graffiti barrier to all external wall faces (no visible colour) to meet SOPA standards.

#### Comments

- Installation to engineers final specification.
- Top of walls to be a consistent RL.
- Wall to have 5mm pencil round edge.
- If wall height is greater than 1000mm above pavement it will require balustrade to meet AS 1428 and SOPA Access Guidelines.
- Colour to be 30% contrast to adjacent paving.
- Multi-functional use as a seating element in the Public Domain and to resolve changes of level.
- Only to be used at level changes under awnings and colonnades if steps or ramps are not possible.

### Insitu Concrete Retaining Seat Wall

AR

#### Principle

To provide additional seating opportunities in the public domain.

#### 2009

Section 3.1  
Pavements and Level Changes

#### DESIGN INTENT ONLY

## Typical Paved Steps



### Material/Finish

- 60mm depth honed stone aggregate concrete paved stairs.
- For TGSi's refer P21.
- For handrail refer SF12 and 13.

### Construction

- Stair must conform with AS 1428 and SOPA Access Guidelines.
- Installation to engineers final specification.
- Pavers installed on steps must have honed finish to all exposed step and tread faces.
- Stairs to be certified by an access consultant.
- Step tread and risers to comply with AS 1428.2.
- Top step to be horizontal. Avoid sloping top steps where practical.
- Non-slip insert to treads to comply with AS 1428 and SOPA Access Guidelines.

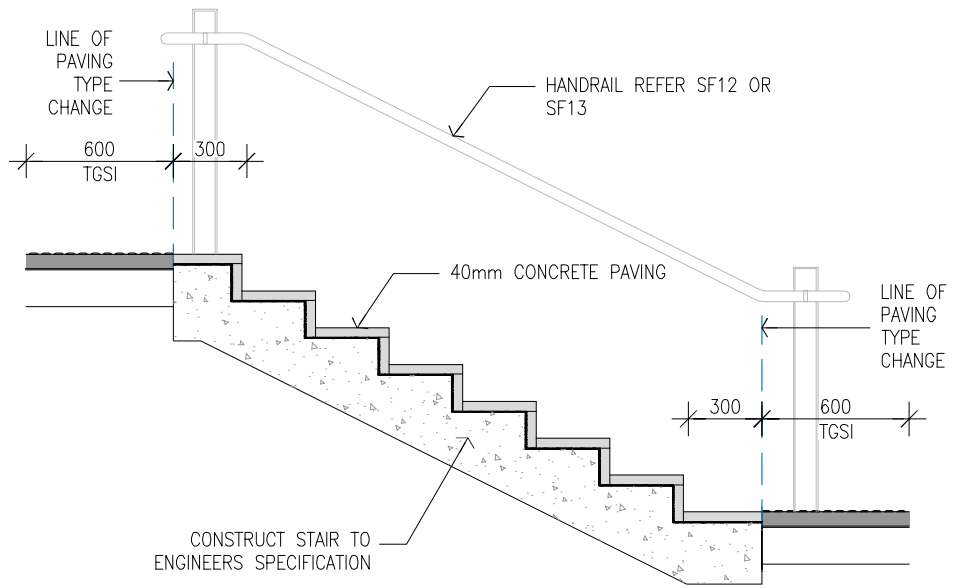

## Section

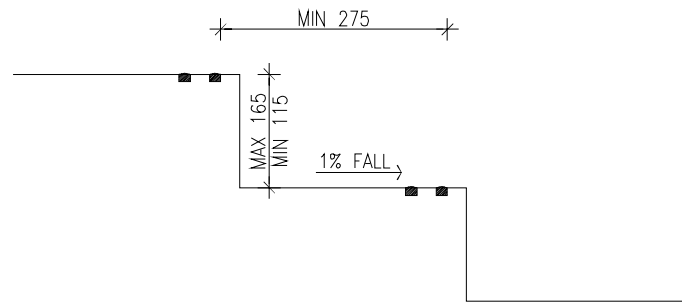

## Detail

### Havenslab 60mm

Size: 400x200x60mm:

Ebony, Golden Glaze aggregate, honed:

AR

### Typical Concrete Steps

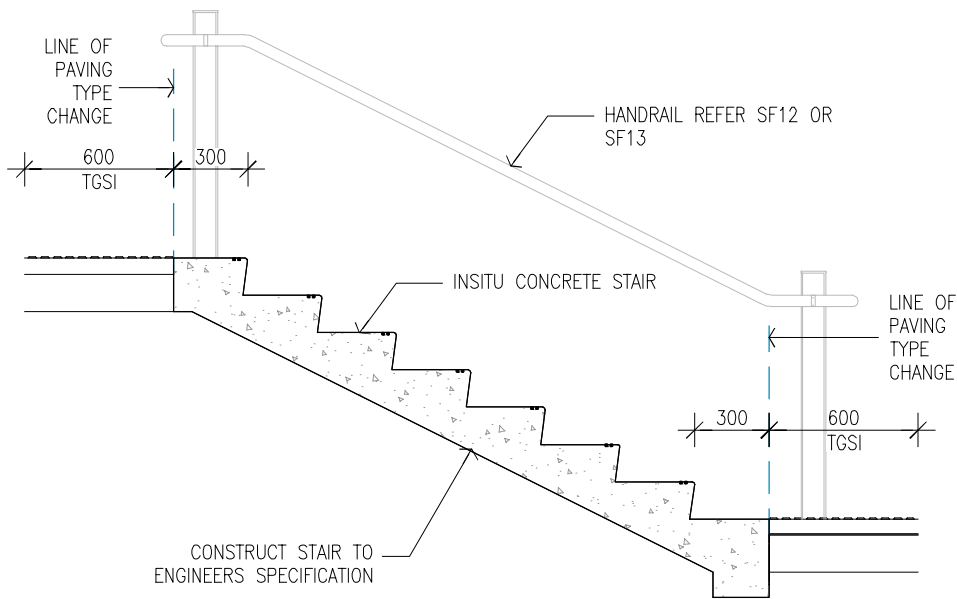

### Section

#### Material/Finish

- Insitu concrete stair.
- Colour – off white (colour sample to be approved by SOPA).
- For TGS's refer P21.
- For handrail refer SF12 and 13.

#### Construction

- Stair must conform with AS 1428 and SOPA Access Guidelines.
- Installation to engineers final specification.
- Stairs to be certified by an access consultant.
- Step tread and risers to comply with AS 1428.2.
- Top step to be horizontal. Avoid sloping top steps where practical.
- Non-slip insert to treads to comply with AS 1428 and SOPA Access Guideline.

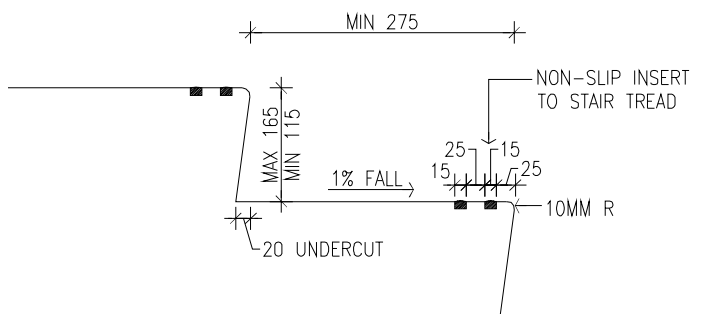

### Detail

AR

Principle

2009

DESIGN INTENT ONLY

Section 3.1  
Pavements and Level Changes

P6B

## Typical Ramp

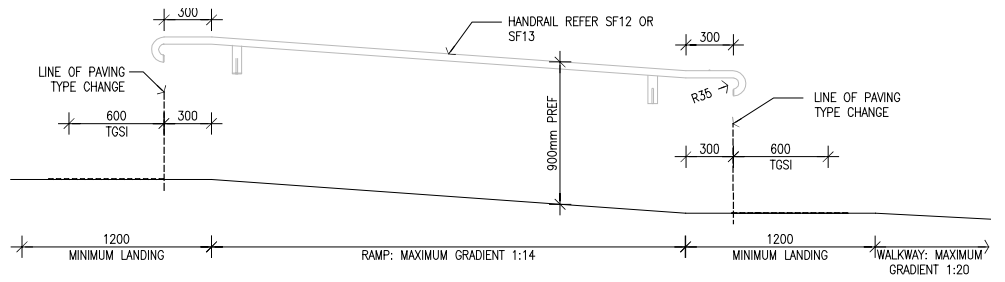

### Material

- Large Format Paver — P11 or paver to match adjacent paving.

### Construction

- Where practical use a walkway (gradient <1:20) so that handrails can be avoided.
- Ramp must conform with AS 1428 and SOPA Access Guidelines.

AR

### Typical Permeable Paving

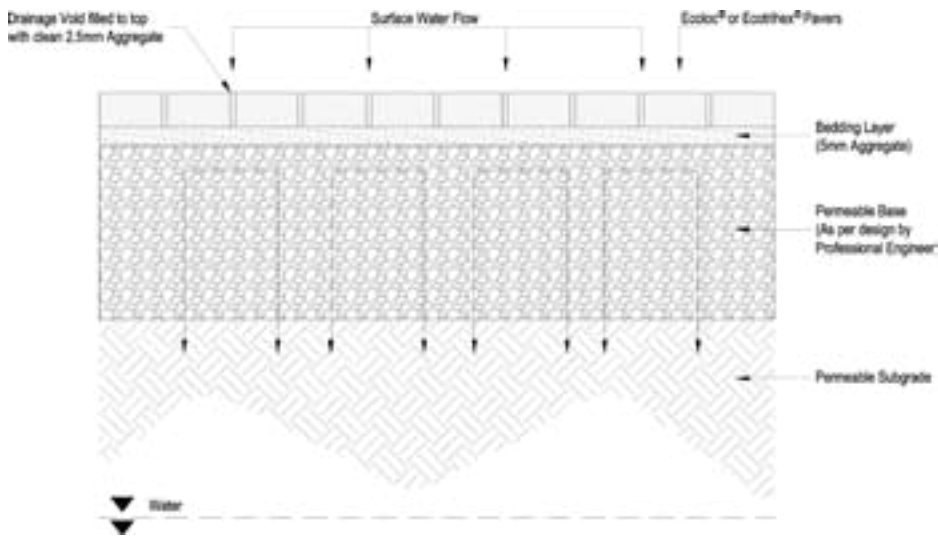

### Ecotrihex 80mm

Ebony, basalt aggregate, honed:

Steel (match existing aggregate), honed:



#### Material

- 80mm depth concrete interlocking segmental permeable pavers.

#### Construction

- Installation to manufacturers instructions and engineers final specification.
- Lay paving to required falls and levels.
- Pavers abutting fixed objects require 10mm sealant joints colour matched to surrounding paving.
- Cut pavers to neatly fit around all penetrations and fixtures including pit covers, poles, signs etc.
- Paving courses to be at 90 degrees to kerb unless otherwise noted.
- Set out of pavers is generally from kerb and cut to building line.
- Where paving border follows a curved alignment border pavers are to be cut to a curve – faceted pavers are not acceptable.
- Saw-cut make-up units must not be less than 30% of original size.

#### Manufacturer's Details

C and M Masonry  
20 Kelso Crescent  
Moorebank NSW 2170

#### Contact

Ph: (02) 9822 6822  
Fax: (02) 9601 7446  
Web: www.cmbrick.com.au

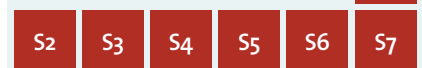

**Principle**  
For water sensitive urban design initiatives to allow water penetration, storage and infiltration in paved surfaces wherever possible.

**2009**  
Section 3.1  
Pavements and Level Changes

**DESIGN INTENT ONLY**  
**P8**

## Typical Precast Pavers Interlocking



### Material

- 80mm depth concrete interlocking segmental pavers (no chamfers).

### Construction

- Installation to manufacturers instructions and engineers final specification.
- Recycled base material to engineers final specification.
- Lay paving to required falls and levels.
- Pavers abutting fixed objects require 10mm sealant joints colour matched to surrounding paving.
- Cut pavers to neatly fit around all penetrations and fixtures including pit covers, poles, signs etc.
- Paving courses to be at 90 degrees to kerb unless otherwise noted.
- Set out of pavers is generally from kerb and cut to building line.
- Where paving border follows a curved alignment border pavers are to be cut to a curve – faceted pavers are not acceptable.
- Saw-cut make-up units must not be less than 30% of original size.

### Manufacturer's Details

C and M Masonry  
20 Kelso Crescent  
Moorebank NSW 2170

### Contact

Ph: (02) 9822 6822  
Fax: (02) 9601 7446  
Web: www.cmbrick.com.au

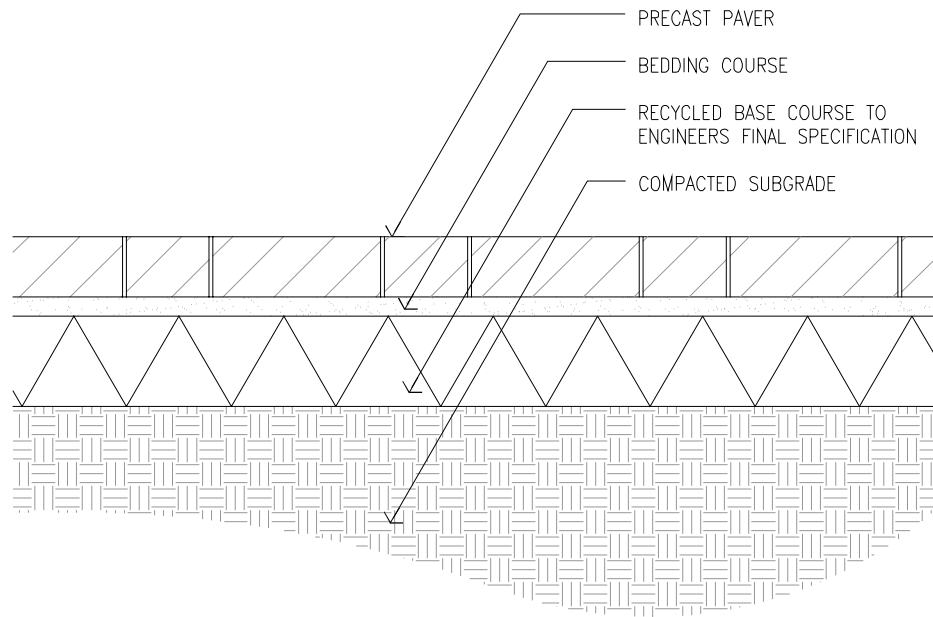

### SECTION

## Trihex 80mm

Ebony, basalt aggregate, honed:

Steel (match existing aggregate), honed:

S3 S4 S5 S6 S7

Terracotta, basalt aggregate, honed:

Sierra, basalt aggregate, honed:

## Unipave 80mm

Ebony, basalt aggregate, standard:

Ebony, basalt aggregate, honed:

Steel, basalt aggregate, standard:

Steel, basalt aggregate, honed:

Terracotta, basalt aggregate, honed:

S1 S2

Sierra, basalt aggregate, honed:

S1 S2

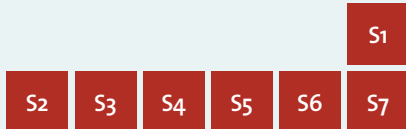

### Typical Precast Pavers Non Interlocking

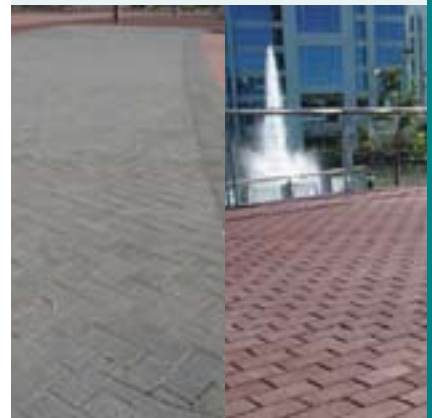
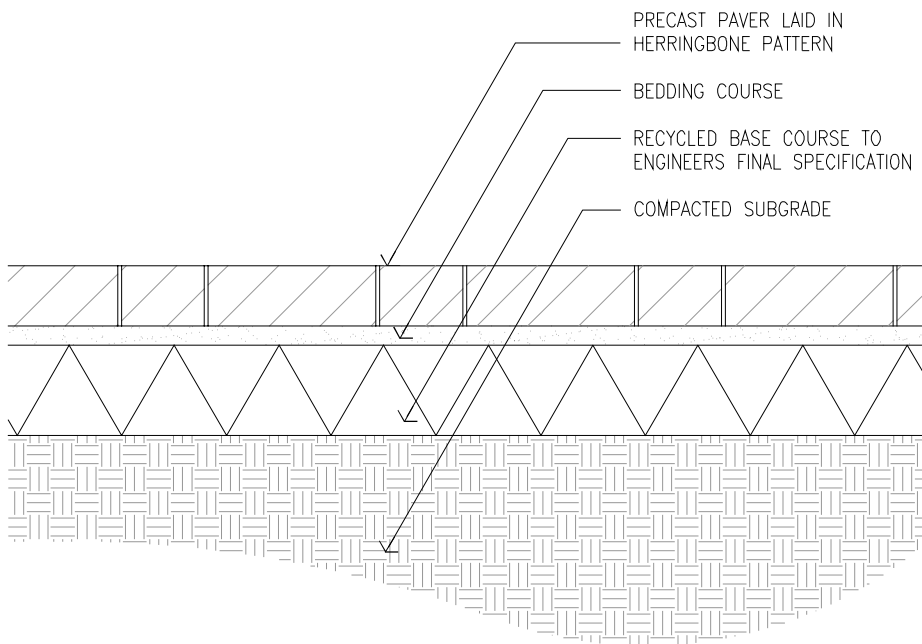

#### SECTION

#### Trupave 222x110x80mm

Ebony Golden Glaze aggregate, honed:

S23

Steel (match existing aggregate), honed:

Terracotta, basalt aggregate, honed:

Sierra, basalt aggregate, honed:

Pedestrian pavement subject to occasional vehicular loads.

#### Material

- 80mm depth concrete segmental pavers (no chamfers).

#### Construction

- Installation to manufacturers instructions and engineers final specification.
- Recycled base material to engineers final specification.
- Lay paving to required falls and levels.
- Pavers abutting fixed objects require 10mm sealant joints colour matched to surrounding paving.
- Cut pavers to neatly fit around all penetrations and fixtures including pit covers, poles, signs etc.
- Paving courses to be at 90 degrees to kerb unless otherwise noted.
- Set out of pavers is generally from kerb and cut to building line.
- Where paving border follows a curved alignment border pavers are to be cut to a curve – faceted pavers are not acceptable.
- Saw-cut make-up units must not be less than 30% of original size.

#### Manufacturer's Details

C and M Masonry  
20 Kelso Crescent  
Moorebank NSW 2170

#### Contact

Ph: (02) 9822 6822  
Fax: (02) 9601 7446  
Web: [www.cmbrick.com.au](http://www.cmbrick.com.au)

S23

#### Principle

High quality pedestrian paver, occasional vehicular loads and edging.

#### 2009

Section 3.1  
Pavements and Level Changes

#### DESIGN INTENT ONLY

P10



## Large Format Pedestrian Paving



### Material

- 60mm depth stone aggregate concrete paving slabs.

### Construction

- Installation to manufacturers instructions and engineers final specification.
- Recycled base material to engineers final specification.
- Lay paving to required falls and levels.
- Pavers abutting fixed objects require 10mm sealant joints colour matched to surrounding paving.
- Cut pavers to neatly fit around all penetrations and fixtures including pit covers, poles, signs etc.
- Paving courses to be at 90 degrees to kerb unless otherwise noted.
- Set out of pavers is generally from kerb and cut to building line.
- Where paving border follows a curved alignment border pavers are to be cut to a curve – faceted pavers are not acceptable.
- Saw-cut make-up units must not be less than 30% of original size.
- Where row trimming is required to maintain laying pattern maximum trim is 50mm – if more than 1 row is trimmed, both trims to be equal.

### Manufacturer's Details

C and M Masonry  
20 Kelso Crescent  
Moorebank NSW 2170

### Contact

Ph: (02) 9822 6822  
Fax: (02) 9601 7446  
Web: www.cmbrick.com.au

S15 S16 S16B S24

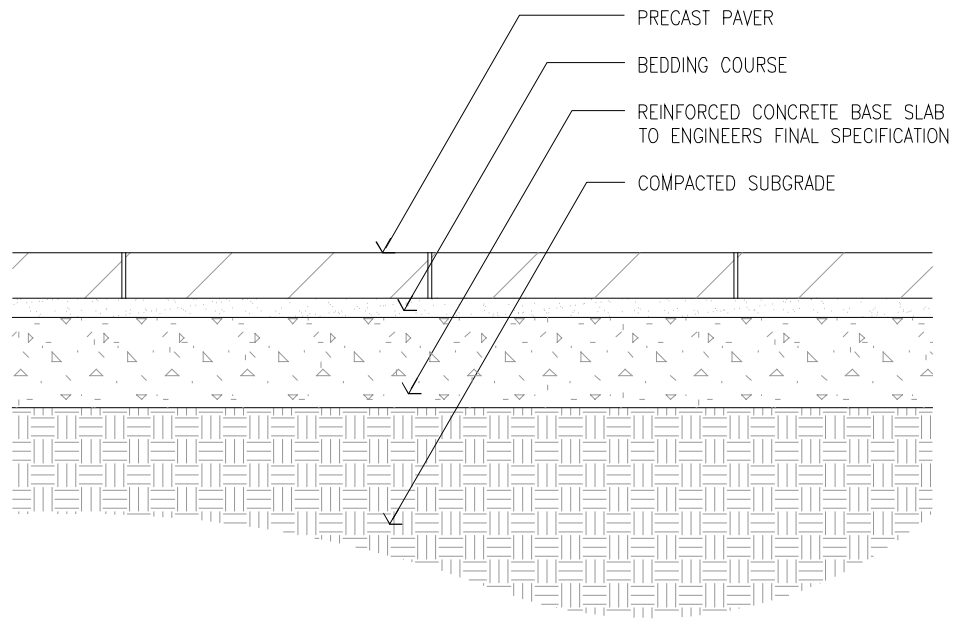

### SECTION

## Havenslab 60mm

Size: 400x200x60mm:

Ebony Golden Glaze aggregate, honed:

S15 S16 S24

### Typical Asphaltic Concrete

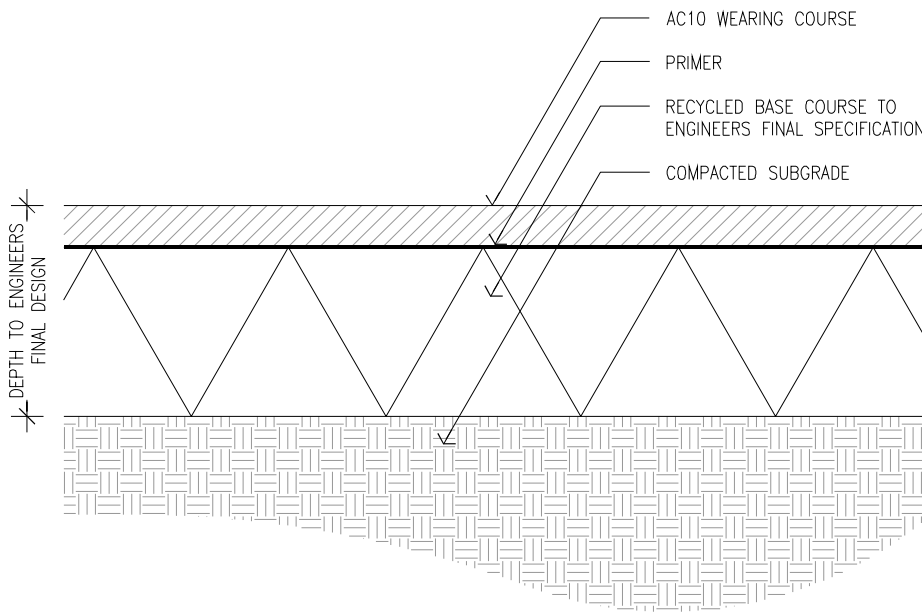

SECTION



**Material**

- 30mm depth AC 10 wearing course.

**Composition**

- Standard mix with standard gravel (blue metal) to engineers final detail.

**Construction**

- Primer seal below wearing course.
- Recycled base material to engineers final specification.

**Maintenance and Repairs**

- Surface repairs to replace full width of pavement to nearest joint or minimum 3m length to avoid patchiness.
- Saw cut edges to adjacent pavement for reinstatement.

		S8	S9	S10	S11
S12	S13	S14	S19A	S19B	S20
S21A	S21B	S22	S25	S26	S27
S28	S29	S30	S31	S32	S33

**Principle**

Footpath pavement finish for streets with verges and building setbacks.

**2009**

Section 3.1  
Pavements and Level Changes

**DESIGN INTENT ONLY**

### Typical Asphaltic Concrete Special

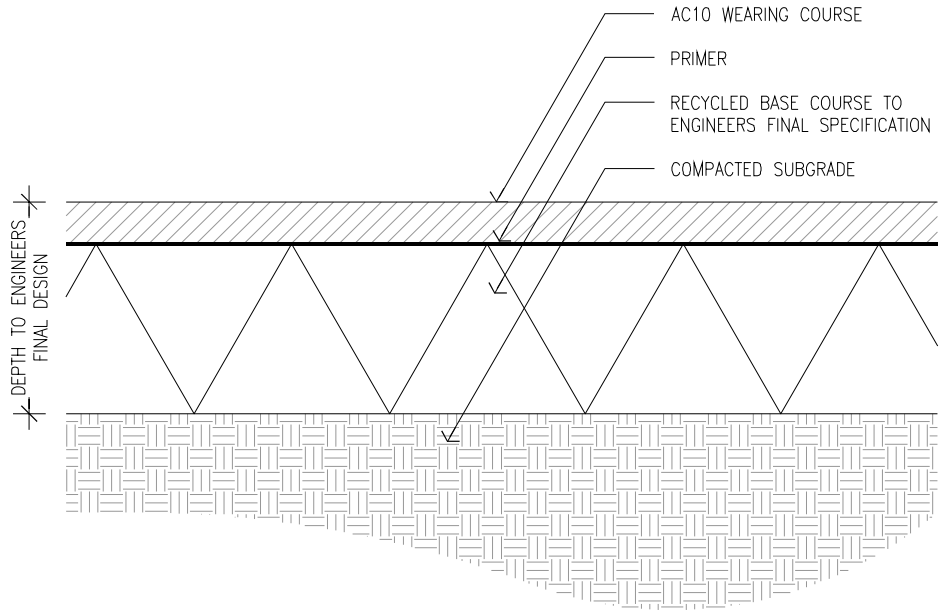

**Material**

- 30mm depth AC 10 wearing course.
- Composition.
- Standard mix with white ryolite gravel or similar to engineers final detail.

**Construction**

- Primer seal below wearing course.
- Recycled base material to engineers final specification.

**Maintenance and Repairs**

- Surface repairs to replace full width of pavement to nearest joint or minimum 3m length to avoid patchiness.
- Saw cut edges to adjacent pavement for reinstatement.

SECTION

AR

### Typical Kerb Ramp – Large

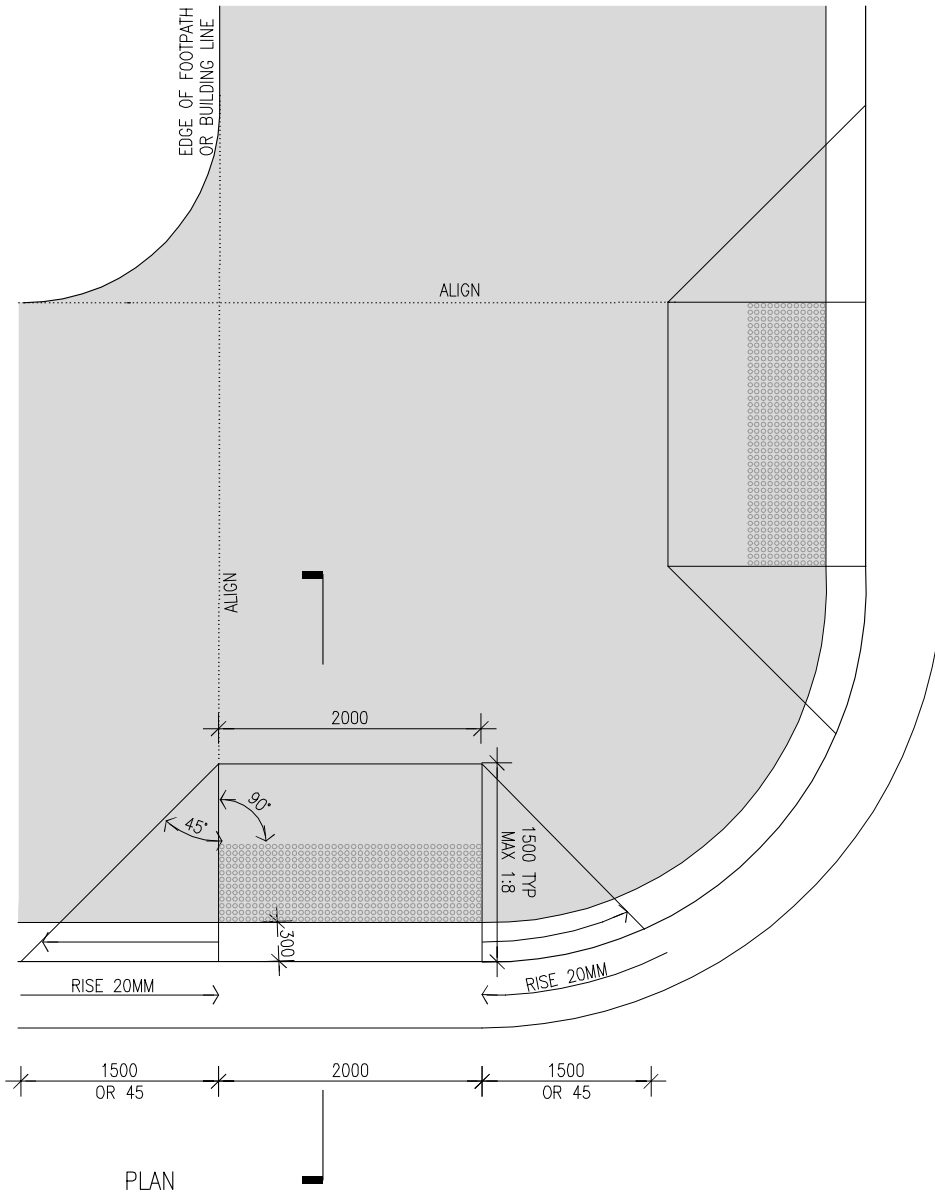

#### Material

- Kerb ramp in surrounding pavement material.
- Kerb set-down and gutter rise as shown.
- Refer detail P21 for tactile ground surface indicators.

#### Construction

- To engineers final specification.
- Recycled base material to engineers final specification.

#### Comment

- Kerb ramps and tactile ground surface indicators to comply with AS 1428 requirements.

					S1
S2	S3	S4	S5	S6	S7
S8	S9	S10	S11	S12	S13
S14	S15	S16A	S16B	S17	S18

#### Principle

To signal road crossing point and provide accessible path.

#### 2009

Section 3.1  
Pavements and Level Changes

#### DESIGN INTENT ONLY

### Typical Kerb Ramp – Small



**Material**

- Kerb ramp in surrounding pavement material.
- Kerb set-down and gutter rise as shown.
- Refer detail P21 for tactile ground surface indicators.

**Construction**

- To engineers final specification.
- Recycled base material to engineers final specification.

**Comment**

- Kerb ramps and tactile ground surface indicators to comply with AS 1428 requirements.

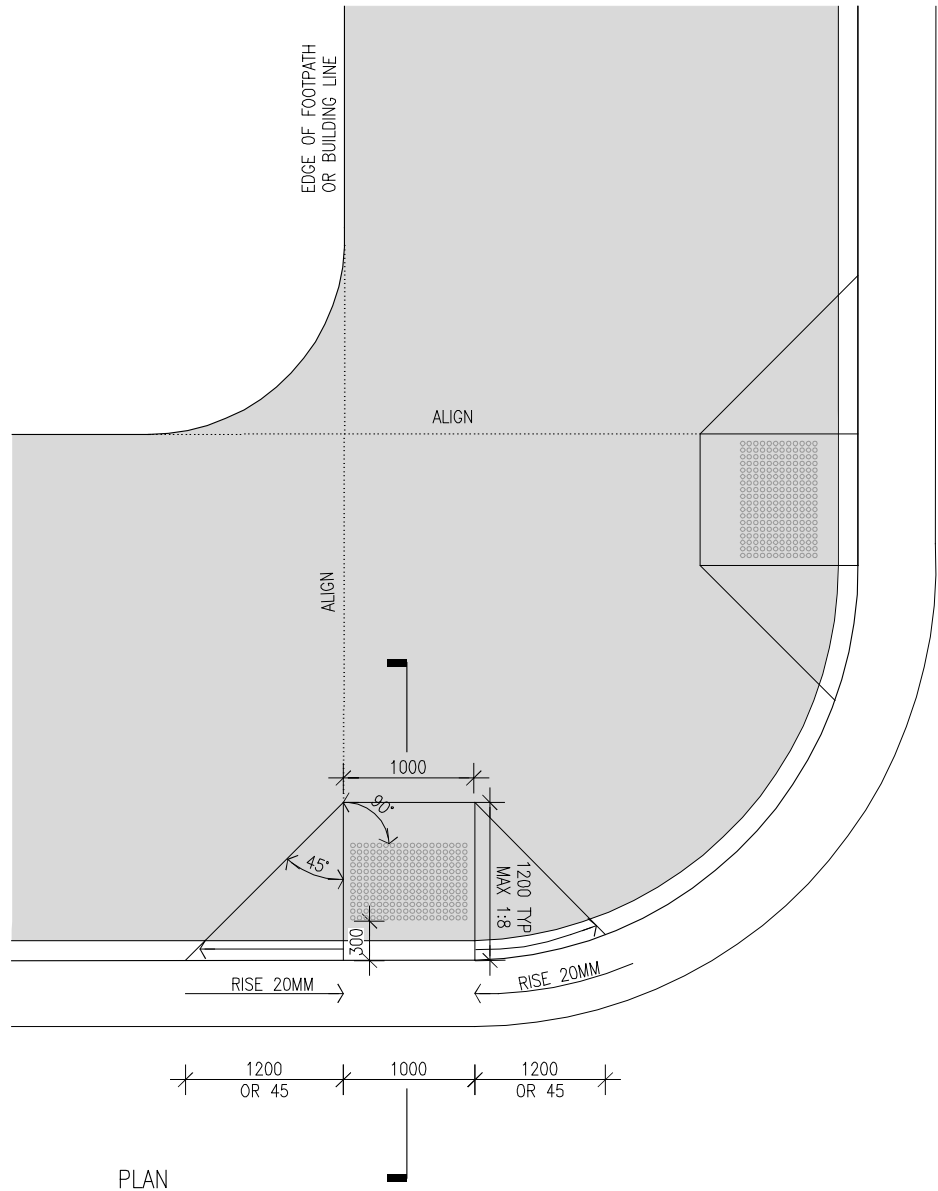

			S19A	S19A	S19B
S20	S21A	S21B	S24	S25	S26
S28	S29	S30	S31	S32	S33

DESIGN INTENT ONLY

P15

2009

Section 3.1  
Pavements and Level Changes

Principle

To signal road crossing point and provide accessible path.

### Typical Vehicle Crossover

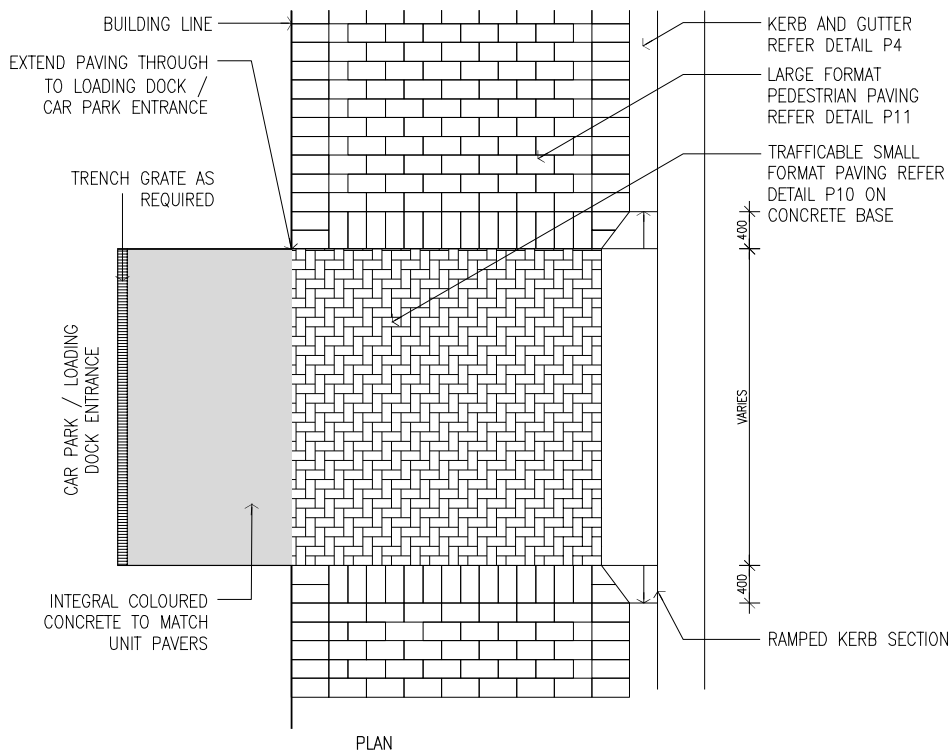

#### Material

- Vehicle crossover in trafficable pavement material as shown.
- Kerb set-down as shown.

#### Construction

- Driveway paving to be laid on concrete base to engineers final specification.
- Recycled base material to engineers final specification.

#### Comment

- Driveways to comply with AS/NZS 2890.1: 2004 Parking Facilities Part 1 – Off Street Parking.

AR

#### Principle

To provide vehicle crossing while allowing priority access to pedestrian footpath.

#### 2009

Section 3.1  
Pavements and Level Changes

#### DESIGN INTENT ONLY

P16

## Typical AC Edge with Planting

### Material

- 100x7mm mild steel edge.

### Finish

- Galvanised.

### Construction

- Peg every 1000mm centres on outside using 10mm diameter, 150mm length galvanised mild steel pegs.
- Galvanised steel plate at joints.

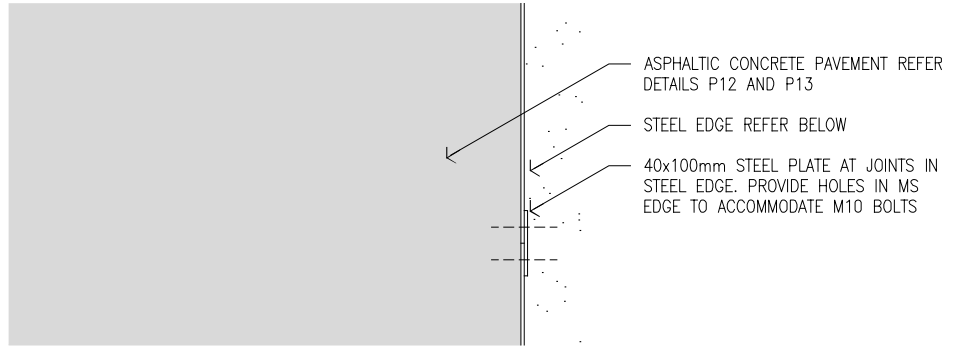

### PLAN

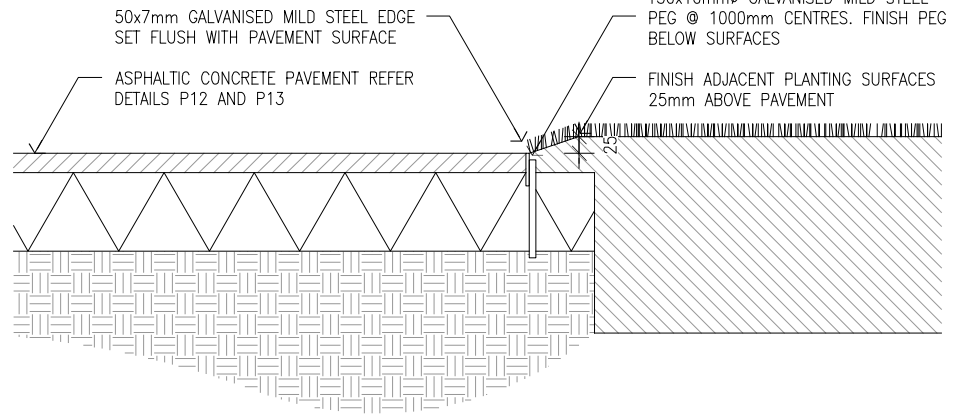

### SECTION

AR

### Typical AC Edge with Pavers

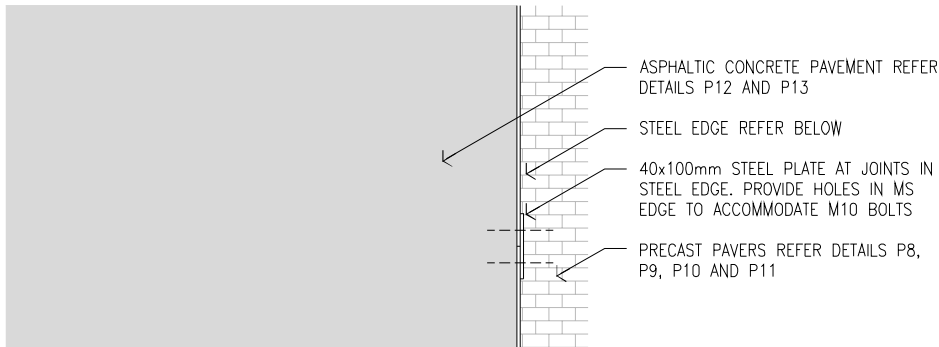

PLAN

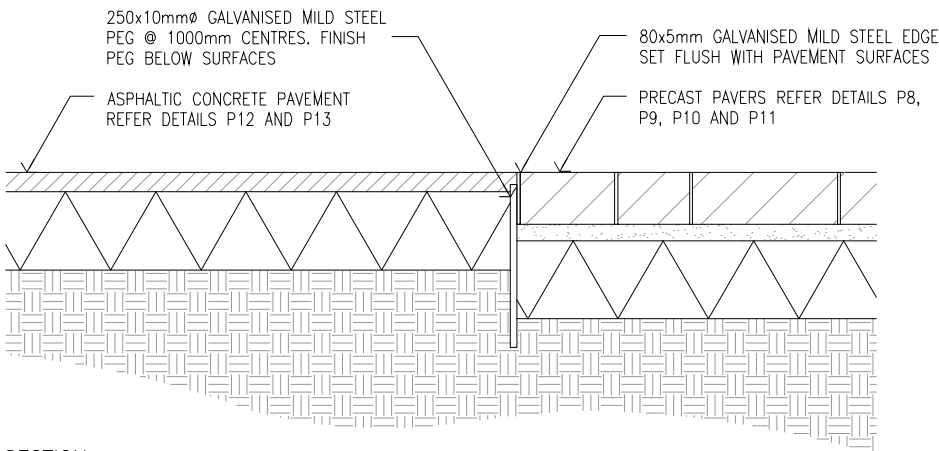

SECTION

**Material**

- 80x5mm mild steel edge.

**Finish**

- Galvanised

**Construction.**

- Peg every 1000mm centres on outside using 10mm diameter, 150mm length galvanised mild steel pegs.
- Galvanised steel plate at joints.

**Principle**

Minimal finishing edge to asphaltic concrete pavement.

**2009**

Section 3.1  
Pavements and Level Changes

**DESIGN INTENT ONLY**



## Typical Gabion Wall



### Material

- Gabion baskets filled with select rocks.

### Finish

- Basalt or sandstone rock infill to engineers specification.

### Construction

- To engineers final specification.
- Not to be used for level changes under awnings or colonnades.
- Select rocks hand packed faces to gabions.

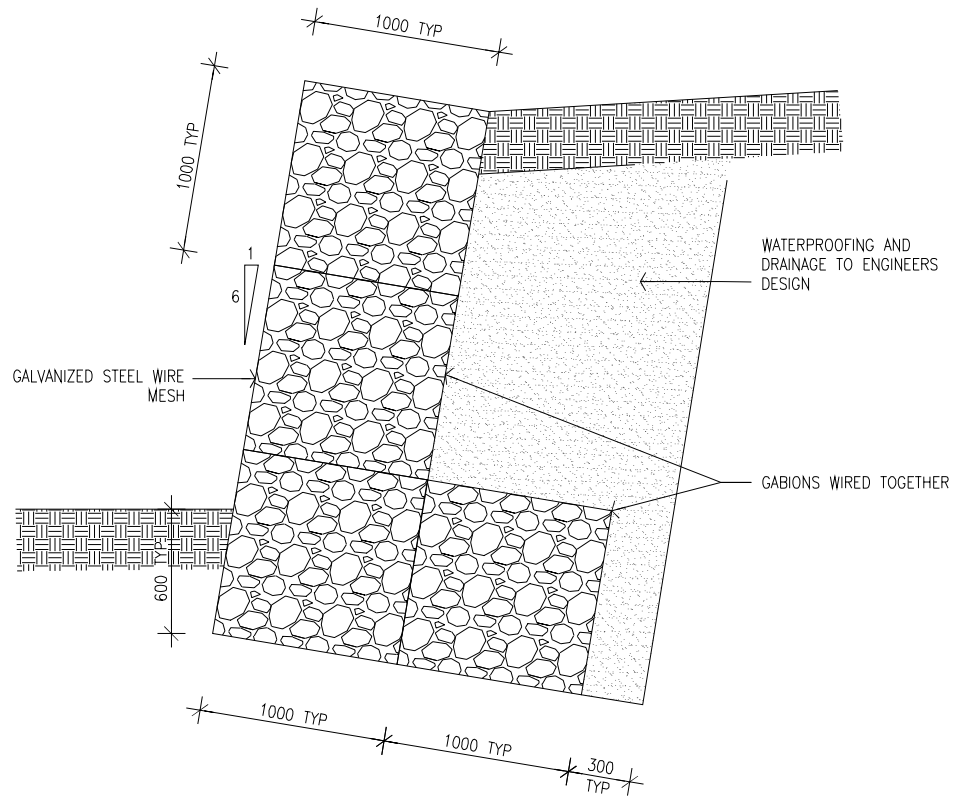

AR

### Typical Basalt Dwarf Wall

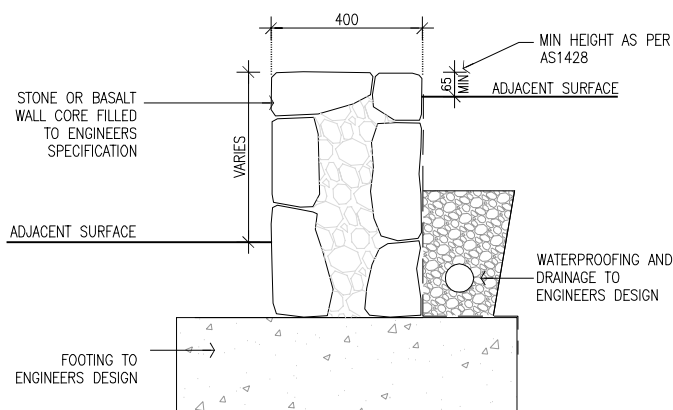

#### Material

- Stone clad wall to match existing.

#### Finish

- To match existing.

#### Construction

- To engineers final specification.
- Only to be used where level changes occur surrounding the Aquatic Centre.

AR

Principle

2009

DESIGN INTENT ONLY

Section 3.1  
Pavements and Level Changes

P20

### Hazard Warning Tactile Ground Surface Indicators



**Product**

- Plastic hazard indicators on a bladed shaft.

**Comment**

- Arrangement to comply with AS 1428 requirements.
- Installation to manufacturers instructions.
- Luminance contrast to comply with AS 1428.4 requirements.

**Note**

- If required luminance contrast cannot be achieved using nominated product seek direction from SOPA before proceeding.

**Model Number: THIBS**

Colour: Yellow.

**Manufacturer's Details**

Pathfinder Systems Australia

**Contact**

Ph: 1300 362 775

Web: [www.pathfindersystems.com.au](http://www.pathfindersystems.com.au)

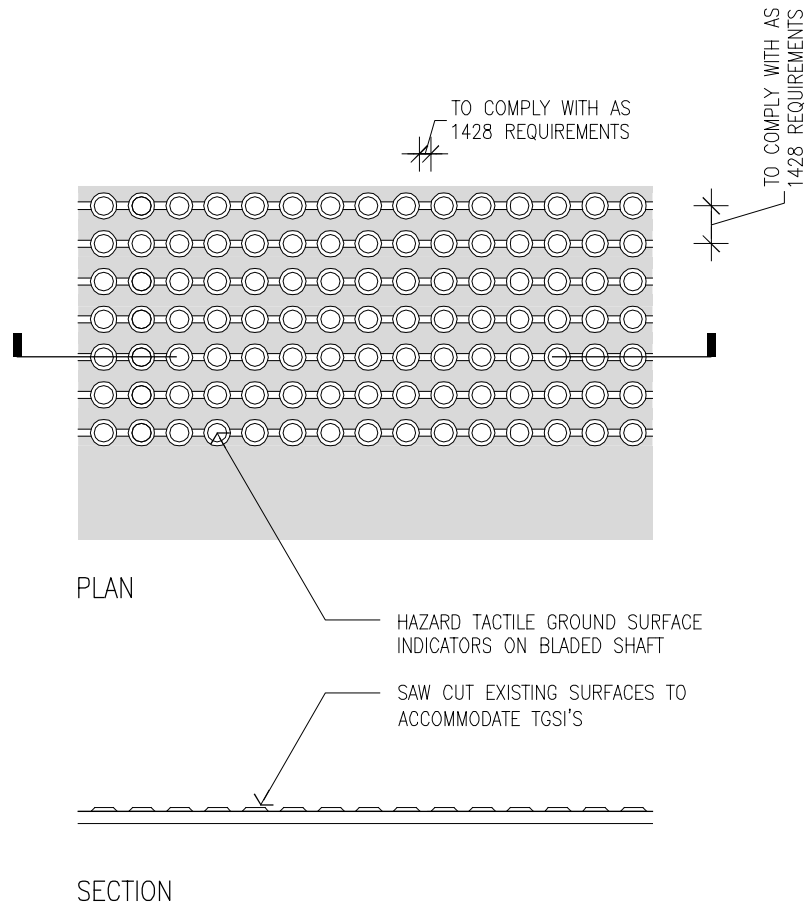

AR

## Directional Tactile Ground Surface Indicators

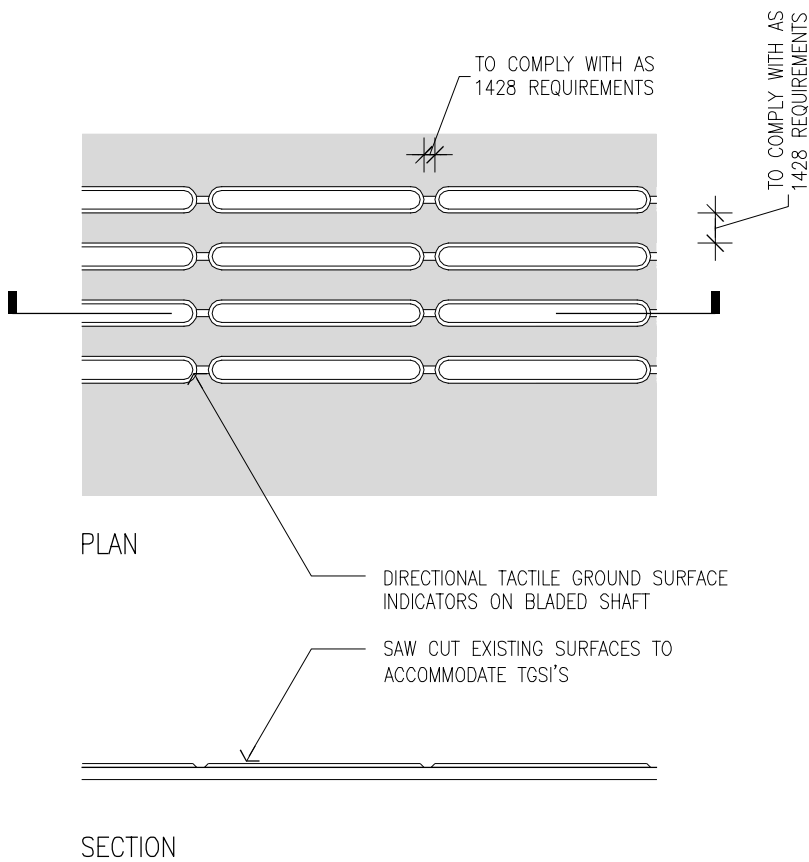

### Product

- Plastic directional indicators on a bladed shaft.

### Comment

- Arrangement to comply with AS 1428 requirements.
- Installation to manufacturers instructions.
- Luminance contrast to comply with AS 1428.4 requirements.

### Note

- If required luminance contrast cannot be achieved using nominated product seek direction from SOPA before proceeding.

AR

### Principle

Tactile ground surface indicator for directional indication to be integrated into surrounding pavement.

2009

Section 3.1  
Pavements and Level Changes

DESIGN INTENT ONLY

P22

## Pavement Base Design

Pavement Layers	Permeable Pavement	Interlocking Pre-cast Pavers (Mixed Vehicular and Pedestrian areas) <sup>1</sup>	Large format (400x200x60mm) Precast Pavers (Pedestrian Areas – No Vehicle Loads) <sup>1</sup>	Asphaltic Concrete Footpath (Pedestrian Areas – No Vehicle Loads) <sup>2</sup>	Asphaltic Concrete Driveway <sup>2</sup>	Non-interlocking Pre-cast Paving Driveway on Concrete Base <sup>3</sup>	Non-interlocking Pre-cast Paving on Concrete Base (Mixed Vehicular / Pedestrian areas) <sup>3</sup>
<b>Sub-grade</b>	Sub-grade CBR to be assessed and compaction specified by the Design Engineer for each site	Sub-grade to be compacted to min 100% SMDD	Sub-grade to be compacted to min 100% SMDD	Sub-grade to be compacted to min 100% SMDD	Sub-grade to be compacted to min 100% SMDD	Sub-grade to be compacted to min 100% SMDD	Sub-grade to be compacted to min 100% SMDD
<b>Sub-base</b>	Granular sub-base material to be specified by Design Engineer for each site	DGS40 to be compacted to min 95% MMDD to finished thickness as specified - 100mm for CBR 3% to 5% - Not required for CBR 5% to 15%	Sub-base material not required	DGS40 to be compacted to min 95% MMDD to finished thickness as specified - 180mm for CBR 3% to 5% - 150mm for CBR 5% to 10% - 100mm for CBR 10% to 15%	DGS40 to be compacted to min 95% MMDD to finished thickness as specified - 220mm for CBR 3% to 5% - 180mm for CBR 5% to 10% - 100mm for CBR 10% to 15%	DGS40 to be compacted to min 95% MMDD to finished thickness as specified - 100mm for CBR 3% to 15%	DGS40 to be compacted to min 95% MMDD to finished thickness as specified - 100mm for CBR 3% to 15%
<b>Base</b>	Granular sub-base material to be specified by Design Engineer for each site	DGB20 to be compacted to min 98% MMDD to finished thickness as specified - 80mm for CBR 3% to 5% - 130mm for CBR 5% to 10% (no sub-base) - 100mm for CBR 10% to 15% (no sub-base)	DGB20 to be compacted to min 98% MMDD to finished thickness as specified - 150mm for CBR 3% to 5% - 130mm for CBR 5% to 10% - 100mm for CBR 10% to 15%	DGB20 to be compacted to min 98% MMDD to finished thickness as specified - 150mm for CBR 3% to 5% - 100mm for CBR 5% to 10% - 80mm for CBR 10% to 15%	DGB20 to be compacted to min 98% MMDD to finished thickness as specified - 200mm for CBR 3% to 5% - 150mm for CBR 5% to 10% - 100mm for CBR 10% to 15%	32MPa concrete slab reinforced with SL72 with 50mm top cover - 160mm for CBR 3% to 5% - 150mm for CBR 5% to 10% - 140mm for CBR 10% to 15%	32MPa concrete slab reinforced with SL72 with 50mm top cover - 140mm for CBR 3% to 5% - 130mm for CBR 5% to 10% - 120mm for CBR 10% to 15%
<b>Wearing Course</b>	Wearing Course to be specified by Design Engineer for each site	80mm thick precast paving units laid in and interlocking pattern, such as herringbone, underlain by nominal 20mm sand bedding layer	60mm thick precast paving units underlain by nominal 20mm sand bedding layer 80mm thick units to be used if subject to potential vehicle loading	Average 25mm layer of AC7 compacted to RTA Spec R116	Average 30mm layer of AC10 compacted to RTA Spec R116	80mm thick precast paving units underlain by nominal 20mm sand bedding layer	80mm thick precast paving units underlain by nominal 20mm sand bedding layer

**Notes**

- Where subgrade is determined to be <3% CBR or >15% CBR, pavements are to be designed for specific site conditions and traffic loadings
- 80mm thick precast paving units are to be rated for vehicular loading
- Pedestrian areas designed for 1x10<sup>3</sup> ESAs; mixed areas designed for 1x10<sup>4</sup> ESAs; vehicular areas designed for 2x10<sup>4</sup> ESAs. Pavements with anticipated traffic loadings outside these ranges or with vehicle loadings of >3t GVM are to be designed for specific site conditions and traffic loadings
- All pavement thicknesses are based upon a 20 year design life
- The thicknesses presented in the above table represent minimum requirements and assume normal site conditions. If irregular or unusual site conditions are encountered, specialist engineering advice should be sought
- Designer to nominate appropriate construction and material specifications

**Design References**

- Cement and Concrete Association of Australia, Concrete Segmental Pavements: Design Guide for Residential Accessways and Roads, March 1997
- 2 APRG Report No 21: A Guide to the Design of New Pavements for Light Traffic, Sept 1998
- Cement and Concrete Association of Australia, Guide to Residential Streets and Paths, Feb 2004



# Street Furniture

Urban Elements Design Manual  
Section

# 3.2

ISBN 978-0-9805976-1-5

© All rights reserved. No part of this work will be reproduced, translated, modified, transmitted or stored in any form by any means without the prior permission of Sydney Olympic Park Authority.

## 3.2 Street Furniture

### Introduction

Street Furniture elements form an integral part of the Sydney Olympic Park public domain identity. The elements are functional and ergonomic with strong simple forms. The range includes catalogue items, assembled items and custom made items. Catalogue items are available from product manufacturers' existing product ranges. Assembled items are those elements created by the combination of standard readily available components. Custom items have been developed where no equivalent or appropriate product exists; these items have been kept to a minimum.

It is envisaged that the range of street furniture will be augmented if new elements become necessary. It is also envisaged that from time to time one off custom pieces of street furniture may be designed, as part of the public art program, or for special public places and parks. One off pieces should be compatible with the main street furniture palette.

### Objectives

Street furniture at Sydney Olympic Park is to achieve the following objectives:

- reinforce the public domain character;
- create a comprehensive and coordinated range;
- be appropriately placed for convenient use;
- be sufficiently robust to withstand heavy use by large crowds during events;
- be sufficiently flexibility to suit different use areas;
- use a minimal and consistent palette of materials;
- achieve environmental principles; and
- minimise life cycle costs and maintenance requirements.

### Relevant Standards

The Street Furniture Strategy is to be read in conjunction with the latest edition of all relevant Australian Standards. Where Australian Standards do not exist, appropriate International Standards will apply.

Relevant Australian Standards include but are not limited to the following:

AS 1428 Design for Access and Mobility.

### Procurement

Procurement of urban elements must comply with the NSW Government's procurement policies.

Free Standing Bubblers

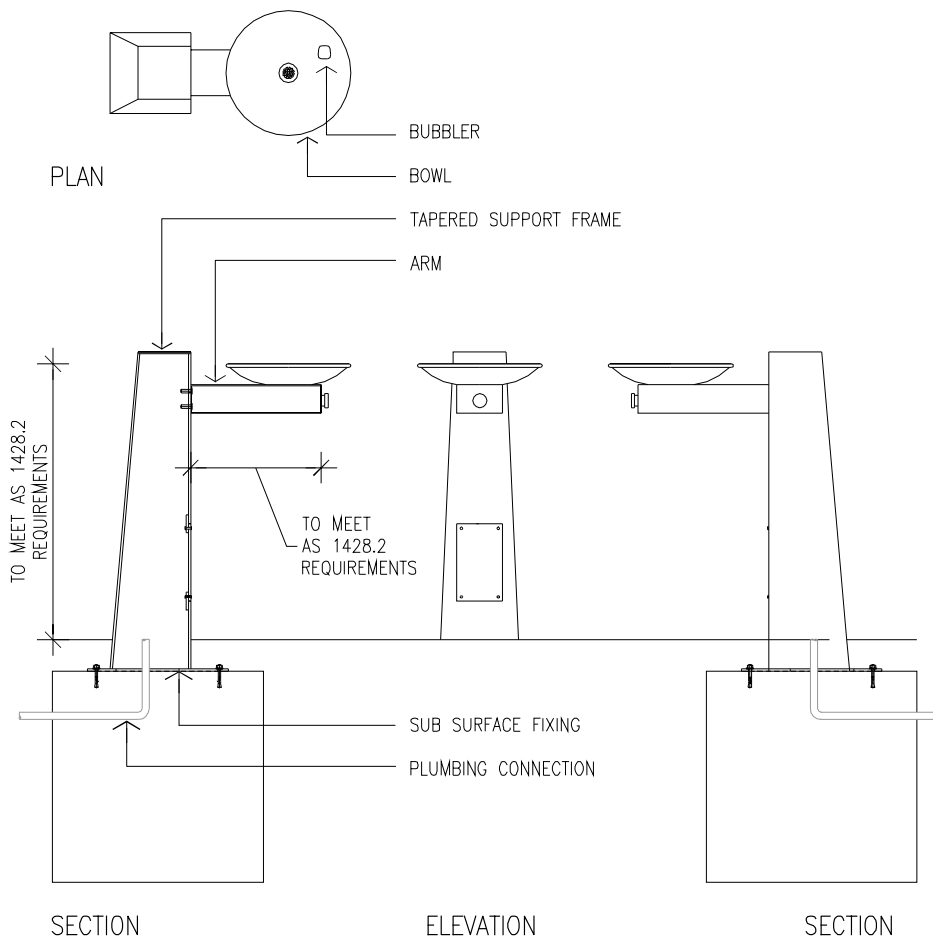

**Material/Finish**

- Stainless steel bowl, outlet and mounting arm.
- Automatic push button valve outlet finish satin.
- Powder coated mild steel tapered pedestal black colour.

**Comments**

- Wheel-chair accessible to AS 1428 requirements.
- Install to manufacturers instructions.
- Subsurface fixing.

**Model No:** DF5001

**Supplier**

Bubbler  
Supplied by Sydney Water

**Manufacturer's Details**

Commercial Systems Australia

15-17 Molan Street  
Ringwood VIC 3134

Ph: (03) 9879 4999

Fax: (03) 9879 4966

**Principle**

Located in parks and adjacent venue entries.

2009

Section 3.2  
Street Furniture

DESIGN INTENT ONLY

SF01



Section 3.2  
Street Furniture

Free-Standing with  
Armrests

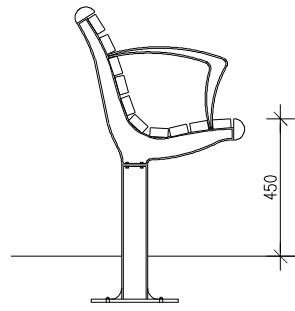

SECTION

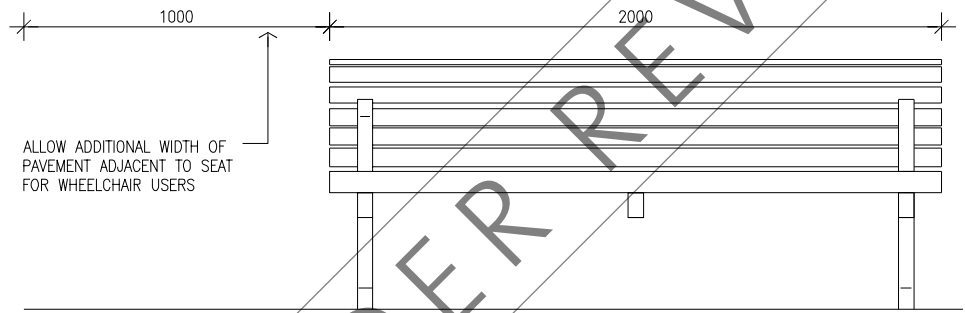

ELEVATION

**Material/Finish**

- Cast aluminium frame and armrest aluminium – raw finish.
- Timber planks.
- Recycled hardwood or plantation timber.
- Timber finish.
- Oil stained using Cabots Natural Oil.

**Fixings**

- Stainless steel tamper proof.

**Comments**

- Install to manufacturers instructions.
- Subsurface fixing.

**Model No: SF02B Bench Seat**

**Manufacturer's Details**

Street and Garden Furniture Co

27 Rogers Street  
West End QLD 4101

Ph: (07) 3844 1951

Fax: (07) 3844 9337

ELEMENT UNDER REVIEW

	S1	S2	S3	S4	
S5	S6	S7	S8	S9	S10
S11	S15	S16A	S16B	S17	S18
S28	S29	S30	S31	S32	S33

DESIGN INTENT ONLY

SF02

2009

Section 3.2  
Street Furniture

**Principle**

Refined, contemporary design; armrests for accessibility. Seats to be located in accordance with SOP Access Strategy.

**Boulevard Bus Shelter**

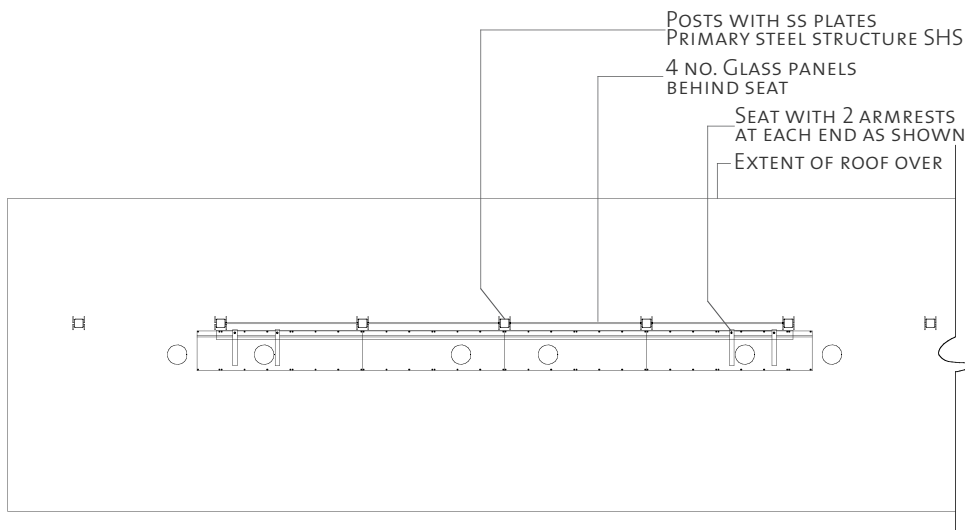
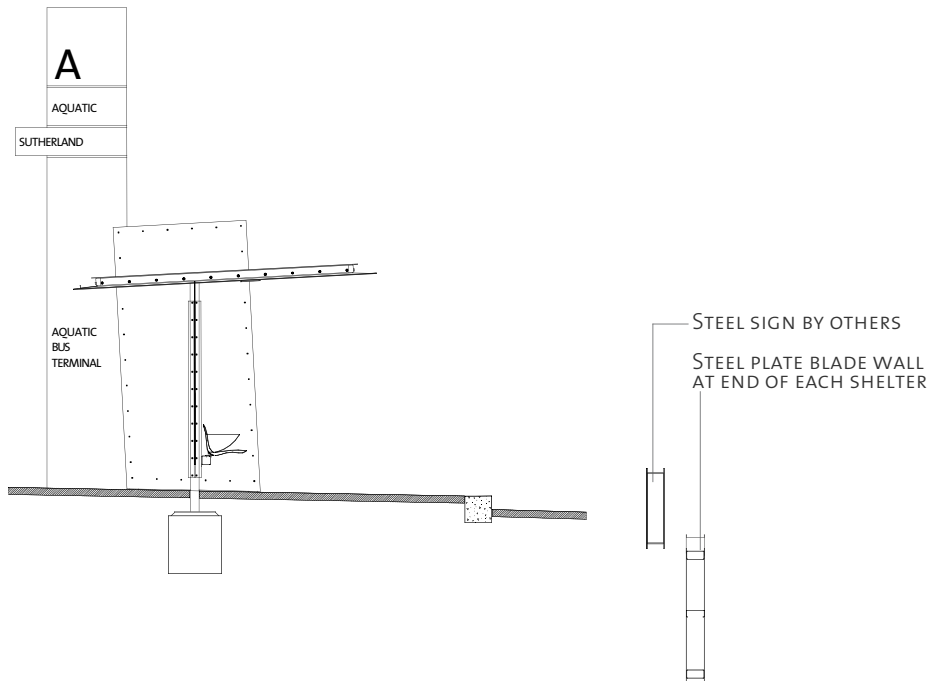

**Material/Finish**

- Steel SHS columns, steel cladding with silver powder coating, stainless steel seat and laminated glass screens.

**Comments**

- Length of shelter varies according to location.

**Manufacturer's Details**

Lahey Constructions

PO Box 617

Kempsey NSW 2440

**Contact**

Ph: (02) 6562 6100

Fax: (02) 6562 8463

**Principle**

Shelter for use in Boulevard.

2009

Section 3.2  
Street Furniture

DESIGN INTENT ONLY

**SF03**

Section 3.2  
Street Furniture

**Ash Cylinder  
– Wall Mounted**



**Material/Finish**

- Cast polished/painted aluminium.
- Finish top – Cast polished aluminium.
- Finish body – Dulux Acrathane charcoal metallic.
- Pole finish – Dulux Acrathane charcoal metallic.

**Comments:**

- Tamper proof lock.
- 3L capacity.
- Wall and building mounting or on a 900mm high 60mm diameter pole as supplied by the manufacturer.

**Manufacturer's Details**

Street Furniture Australia  
(custom designed product)

1/29–33 Bourke Road  
Alexandria NSW 2015

**Contact**

Ph: (02) 9310 1488  
Fax: (02) 9318 1343

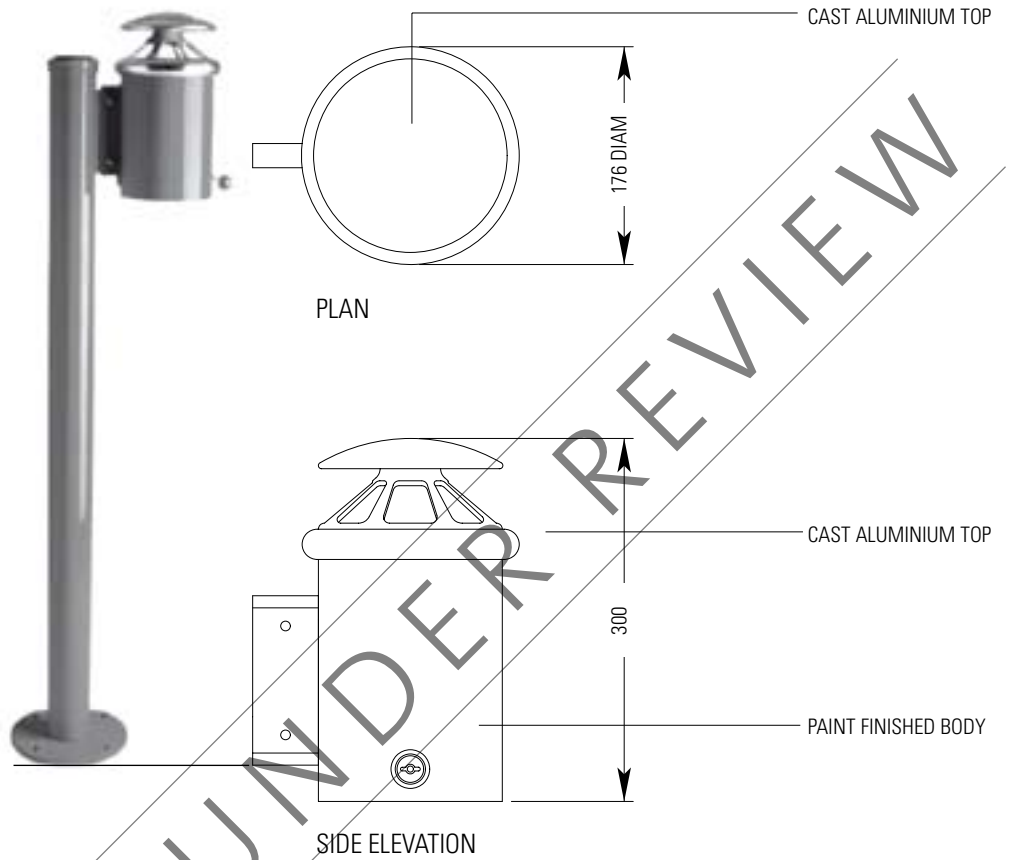

AR

DESIGN INTENT ONLY

SF04

2009

Section 3.2  
Street Furniture

Principle

Ashtray for use as required.

**Platform Bench Seat –  
1800mm**

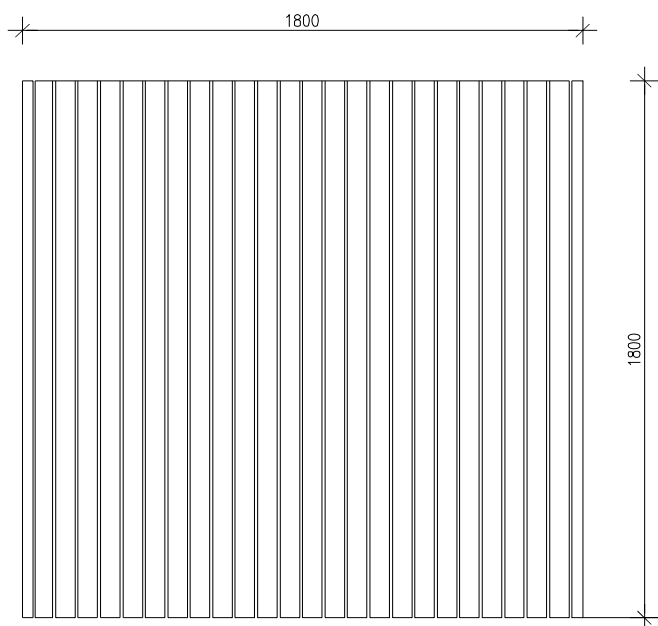

PLAN

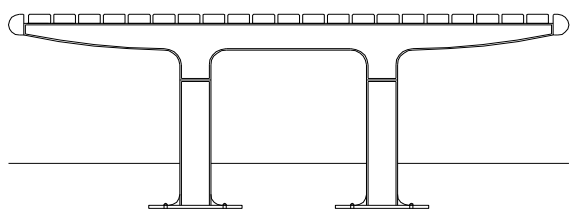

SECTION



**Material/Finish**

- Cast aluminium frame.
- Raw aluminium finish.

**Timber Planks**

- Recycled hardwood or plantation timber.

**Timber Finish**

- Oil stained using Cabots Natural Oil.

**Fixings**

- Stainless steel tamper proof.

**Comments**

- Sub surface fixing.
- Install to manufacturers instructions.

**Model No: SF005 Platform  
Bench Seat**

**Manufacturer's Details**

Street and Garden Furniture Co

27 Rogers Street

West End

QLD 4101

**Contact**

Ph: (07) 3844 1951

Fax: (07) 3844 9337

**Principle**

For use in park areas as required.

**2009**

**Section 3.2  
Street Furniture**

**DESIGN INTENT ONLY**

**SF05**

Section 3.2  
Street Furniture

**Platform Bench Seat –  
900mm**

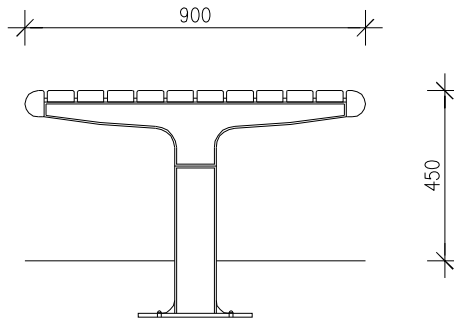

SECTION

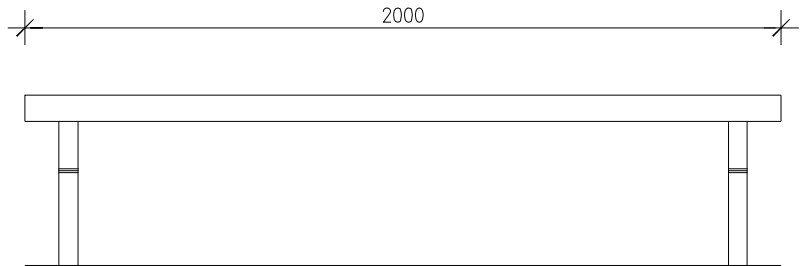

ELEVATION

**Material/Finish**

- Cast aluminium frame.
- Raw aluminium finish.

**Timber Planks**

- Recycled hardwood or plantation timber.

**Timber Finish**

- Oil stained using Cabots Natural Oil.

**Fixings**

- Stainless steel tamper proof.

**Comments**

- Install to manufacturers instructions.
- Subsurface fixing.

**Model No: SF05A Platform  
Bench Seat**

**Manufacturer's Details**

Street and Garden Furniture Co

27 Rogers Street

West End

QLD 4101

**Contact**

Ph: (07) 3844 1951

Fax: (07) 3844 9337

AR

DESIGN INTENT ONLY

**SF05A**

2009

Section 3.2  
Street Furniture

**Principle**

For use in park areas as required.

**Picnic Set**

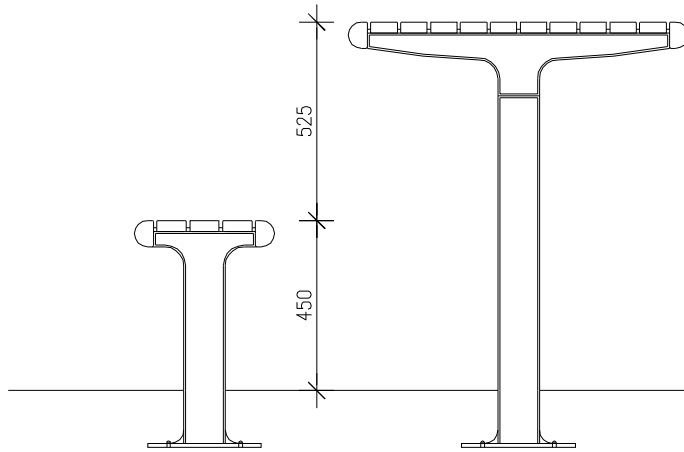

SECTION

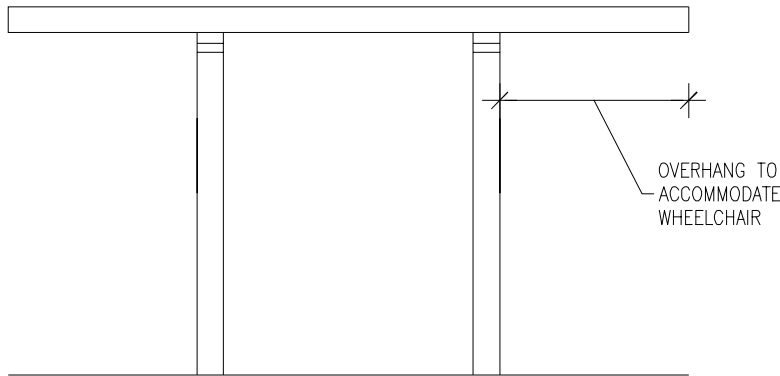

ELEVATION



**Material/Finish**

- Cast aluminium frame (raw aluminium finish).

**Timber**

- Timber planks to be recycled hardwood or plantation timber with clear oil finish using Cabots natural oil.

**Comments**

- Wheelchair accessible to AS 1428 requirements.
- Installation to manufacturers instructions.
- Subsurface fixing.

**Model No: Picnic Table: SFoo6**

Seat: GFG013

**Manufacturer's Details**

Street & Garden Furniture Co

27 Rogers Street

West End

QLD 4101

**Contact**

Ph: (07) 3844 1951

Fax: (07) 3844 933

**Principle**

For use in park areas as required.

2009

Section 3.2  
Street Furniture

DESIGN INTENT ONLY

**SF06**

**Bollard Removable**



**Material/Finish**

- Cast aluminium satin finish.
- Powder coated in Dulux navy in Boulevard only.
- Eyelets (nickel plated Reflective eye) retro-reflective plastic sticker.

**Comments**

- Hole at 1000mm above finished ground level can accept an eyelet for corralling rail. Key operated Lock for removal. Spigot guide compatible with corralling is equipped with reflective eye.
- In-ground element can be installed insitu or cored after paving has been completed.
- Long axis of bollard perpendicular to vehicle/pedestrian route.
- Install to manufacturers instructions.

**Manufacturer's Details**

Street Furniture Australia  
(custom designed product)

1/29-33 Bourke Road  
Alexandria NSW 2015

**Contact**

Ph: (02) 9310 1488

Fax: (02) 9318 1343

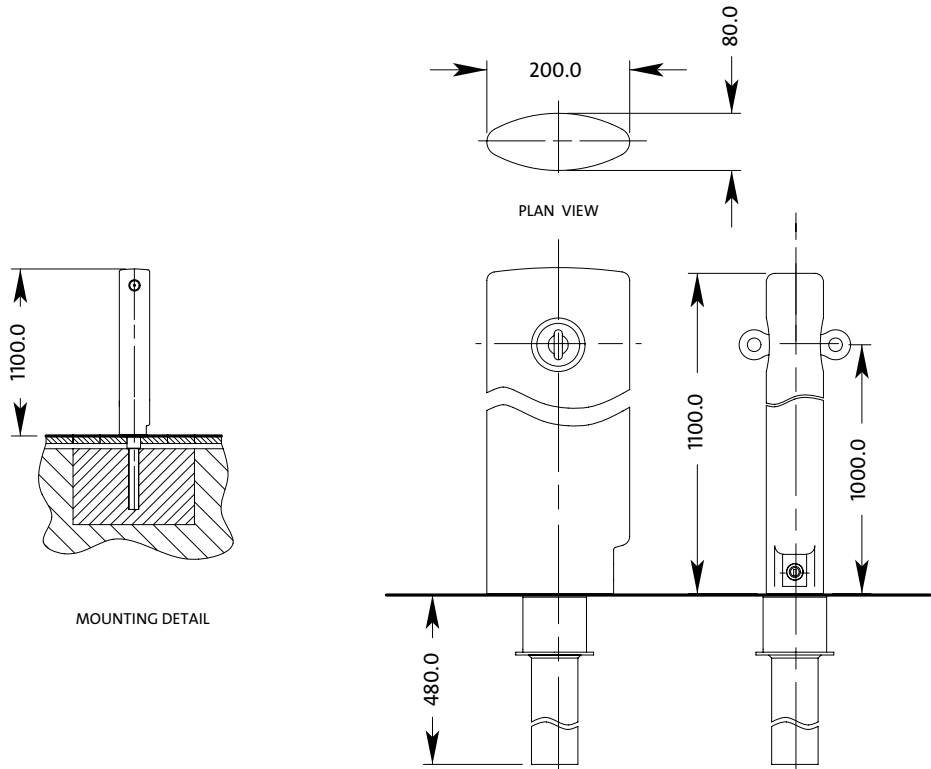

**Bollard Fixed 1100mm**

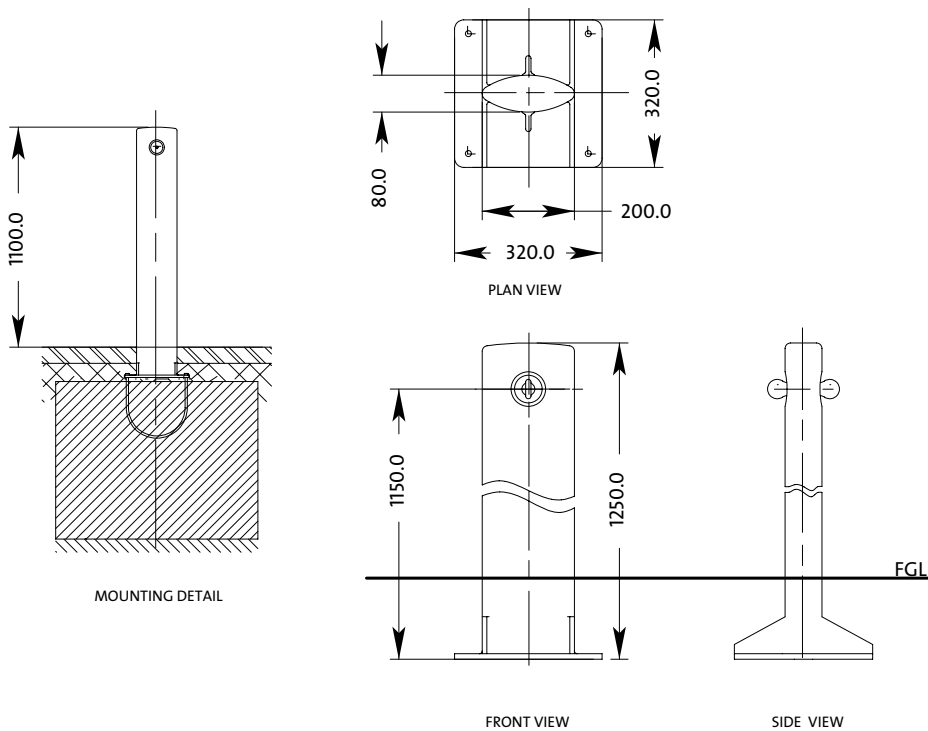

**Material/Finish**

- Cast Aluminium Satin finish.
- Powder coated in Dulux navy in Boulevard only.
- Eyelets – nickel plated Reflective eye – retro-reflective plastic sticker.

**Comments**

- Hole at 1000mm above finished ground level can accept an eyelet for corralling rail. Bollard is equipped with reflective eye.
- Long axis of bollard perpendicular to vehicle/pedestrian route.
- Install to manufacturers instructions.

**Manufacturer's Details**

Street Furniture Australia  
(custom designed product)

1/29–33 Bourke Road  
Alexandria NSW 2015

**Contact**

Ph: (02) 9310 1488

Fax: (02) 9318 1343

**Principle**

Where required at edges of areas with flush kerbs or swales.

**2009**

**Section 3.2  
Street Furniture**

**DESIGN INTENT ONLY**



Section 3.2  
Street Furniture

**Bike Rail Freestanding**

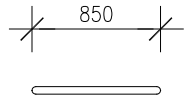

PLAN VIEW

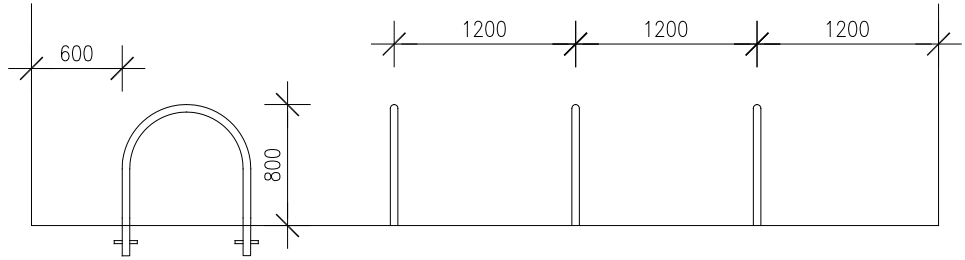

FRONT VIEW

SIDE VIEW

**Material/Finish**

- Stainless steel.

**Comments**

- Layout of bike rails to comply with AS 2890 – 1993.
- Sub surface fixing.
- Install to manufacturers instructions.

**Model No: BR85F**

**Manufacturer's Details**

Securabike  
Leda – Vannaclip  
8/185 Briens Rd  
Northmead, NSW, 2152

**Contact**

Ph: (02) 8006 5600  
Fax: (02) 8006 5699  
www.securabike.com.au

AR

Tree Grate Square

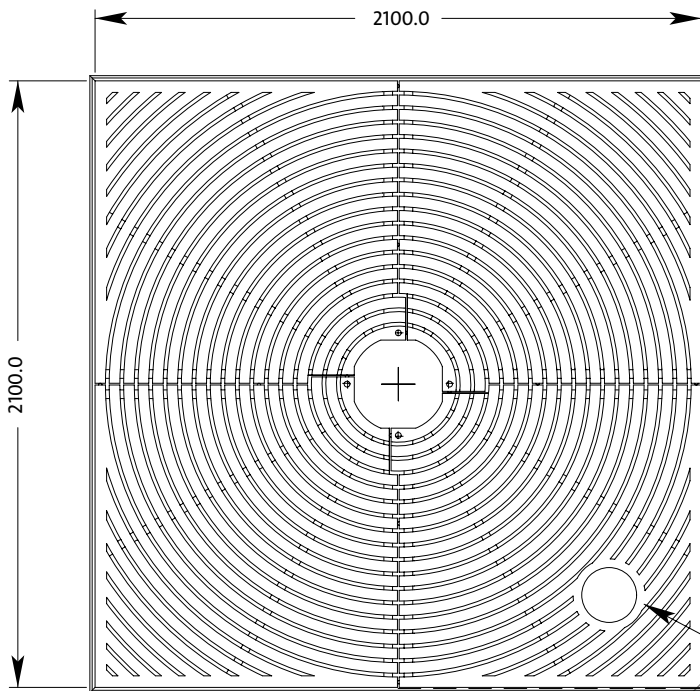

Material/Finish

- Cast iron grate and angle frame and support frame.
- Frame – hot dip galvanised.
- Precast concrete base.
- Casting finish – Bitumus black.

Comments

- For use in pedestrian areas only.
- Rings can be cut away to allow tree growth.
- Maximum gap to comply with AS1428 requirements.
- Set flush with pavement.
- Set concrete surround below pavement.
- Install to manufacturers instructions.

Manufacturer's Details

Grate and Surround (pedestrian)

Product Code: 29004

WK Moodie and Associates

PO Box 3040

Monash Park NSW 2111

Contact

Ph: (02) 9816 1133

Fax: (02) 9816 3417

Web: [www.moodie.com.au](http://www.moodie.com.au)



ELEMENT UNDER REVIEW

S4 S5 S7

S15 S16A S16B S17 S18 S25

Principle

For use in pedestrian areas only.

2009

Section 3.2  
Street Furniture

DESIGN INTENT ONLY

SF10

**Parking Meter**



**Material/Finish**

- As per manufacturer's specification.

**Comments**

- To be supplied by SOPA Operations.

**Manufacturer's Details**

TTM Equipment Pty Ltd

Unity 2-13 Penny Place  
Arndell Park NSW 2148

**Contact**

Ph: (02) 9676 3000

Fax: (07) 9676 3022

AR

Handrail Vertical Mount

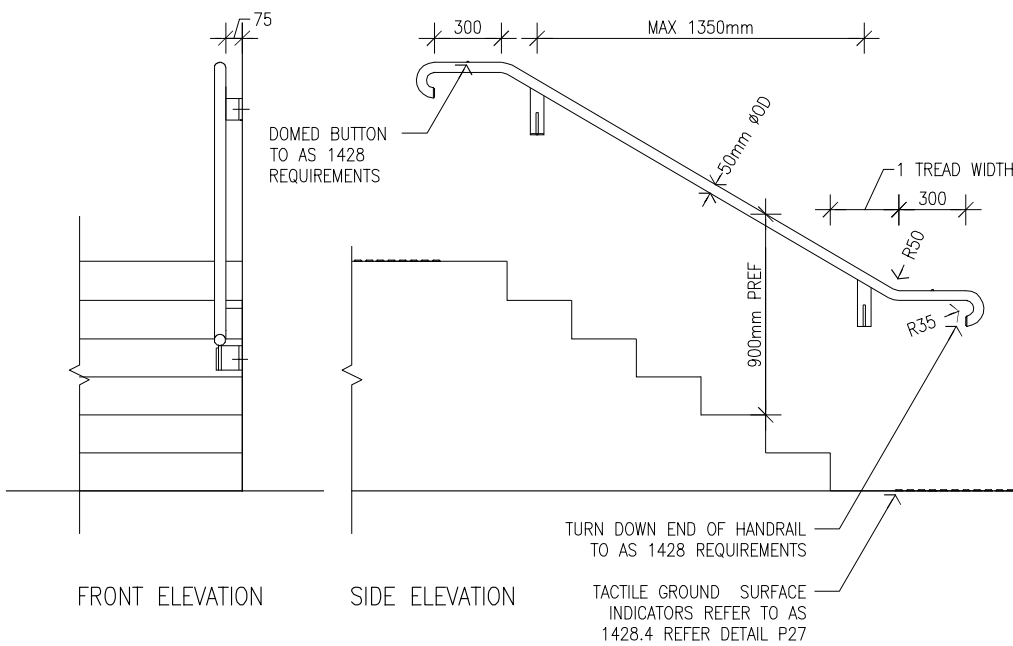

Material/Finish

- Stainless steel.

Comments

- Assembled from readily available standard steel plate and CHS.
- Handrail to comply with AS 1428.
- Tactile ground surface indicators to comply with AS 1428.
- Refer details P21 and P22 for tactile ground surface indicators.

Principle

Handrail detail for use as required in public domain areas.

2009

Section 3.2  
Street Furniture

DESIGN INTENT ONLY

Handrail Freestanding



Material/Finish

- Stainless steel.

Comments

- Assembled from readily available standard steel plate and C.H.S. and U.C. section.
- Tactile ground surface indicators to comply with AS 1428.
- Refer details P21 and P22 for tactile ground surface indicators.

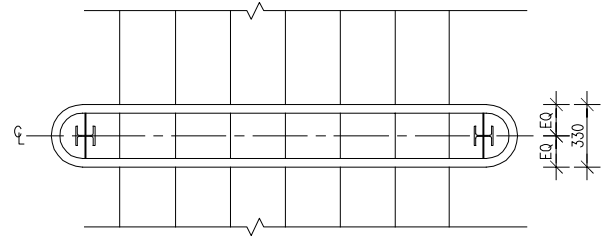

PLAN

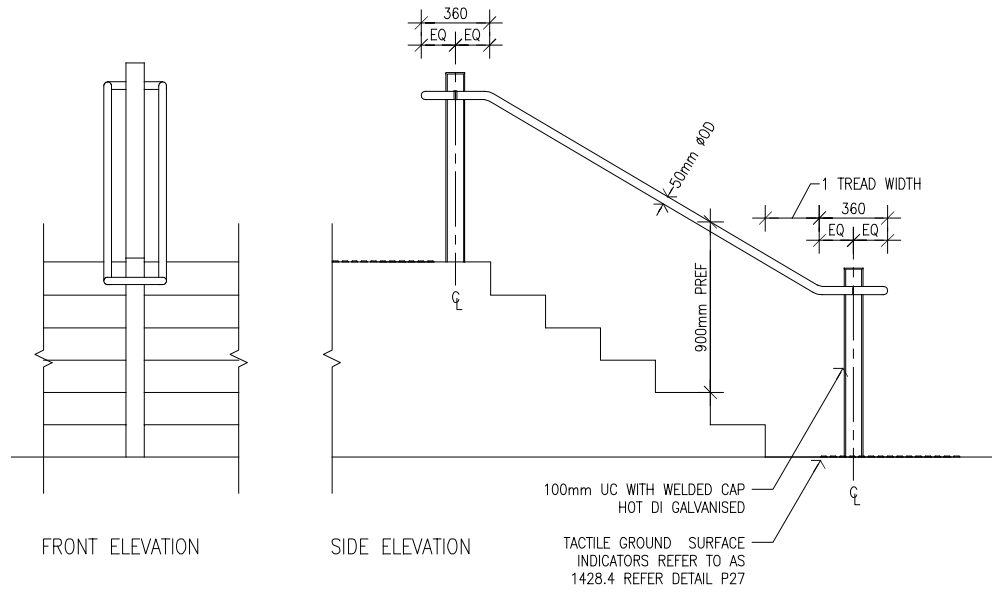

FRONT ELEVATION

SIDE ELEVATION

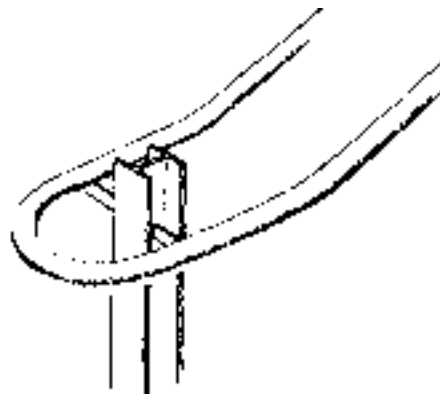

AR

### Typical Fencing Type One

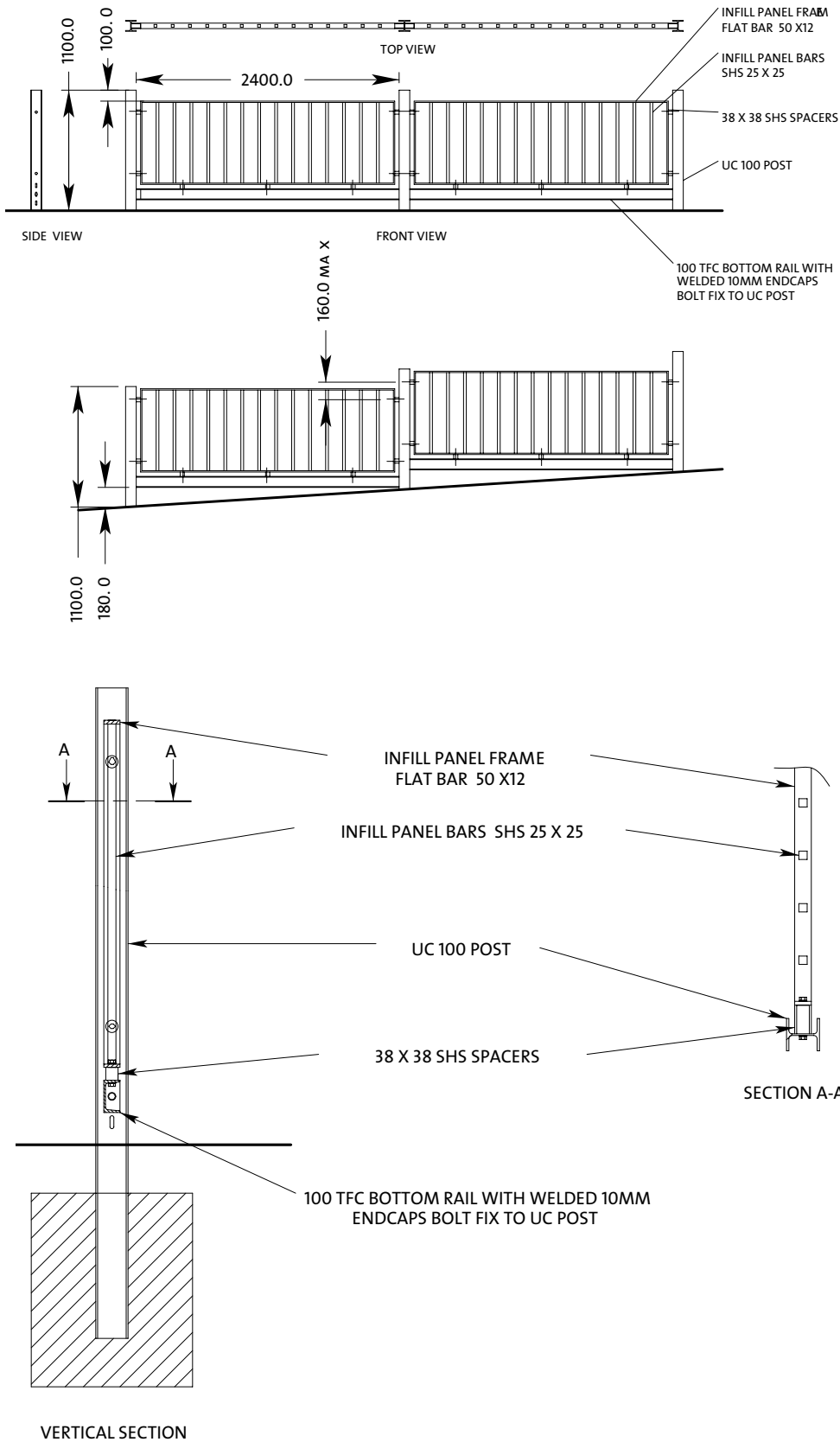

**Material/Finish**

- Mild steel hot dip galvanised.

**Comments**

- Assembled from readily available simple components. To comply with BCA requirements.

**Placement**

- Refer to SOPA Fencing Strategy.

AR

**Principle**

Low steel fence for use as required.

2009

Section 3.2  
Street Furniture

DESIGN INTENT ONLY

SF14

### Typical Fencing Type Two

**Material/Finish**

- Mild steel hot dip galvanised.

**Comments**

- Assembled from readily available simple components. To comply with BCA requirements.

**Placement**

- Refer to SOPA Fencing Strategy.

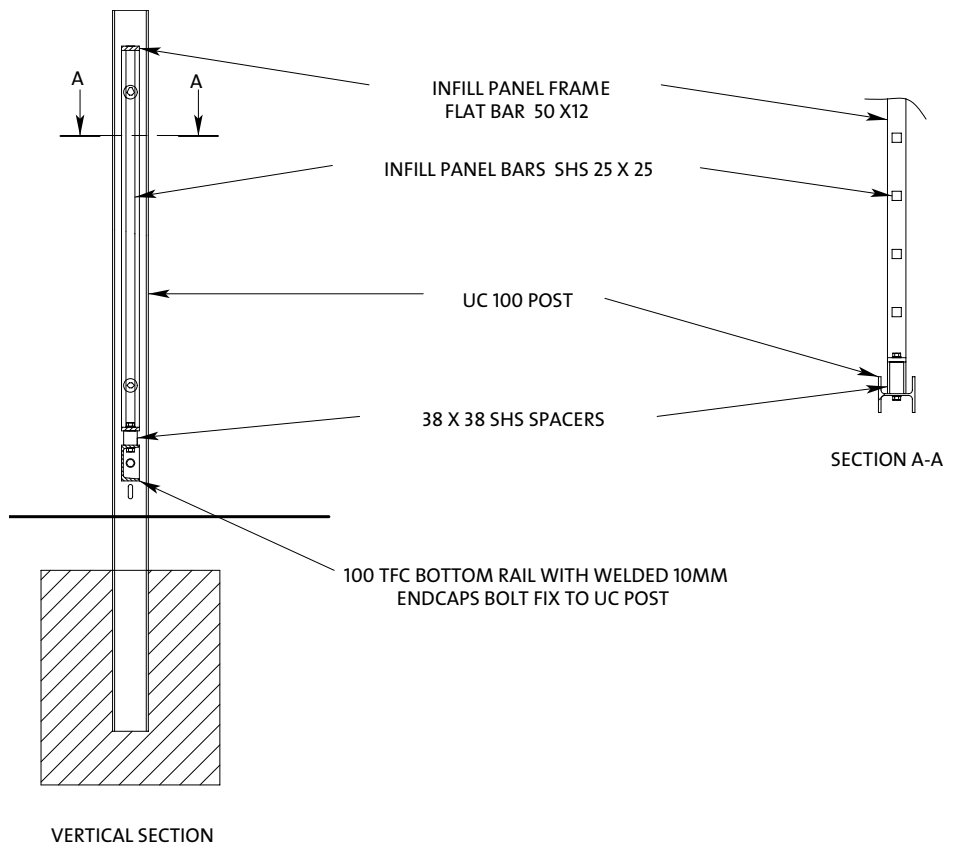
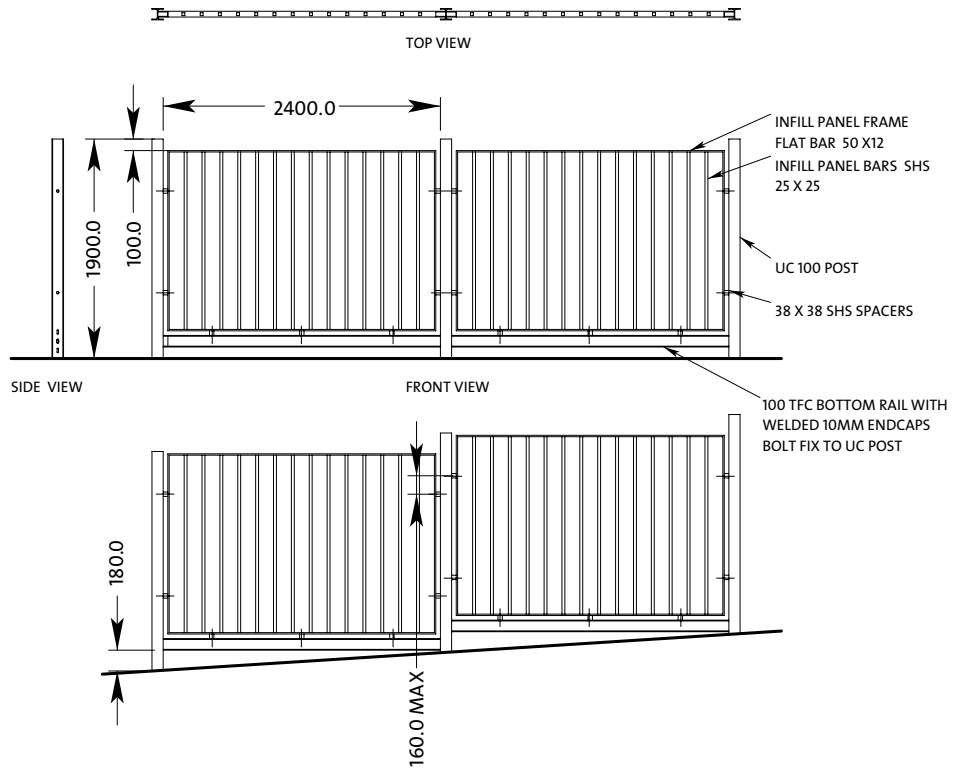

AR

Typical Fencing Type Three

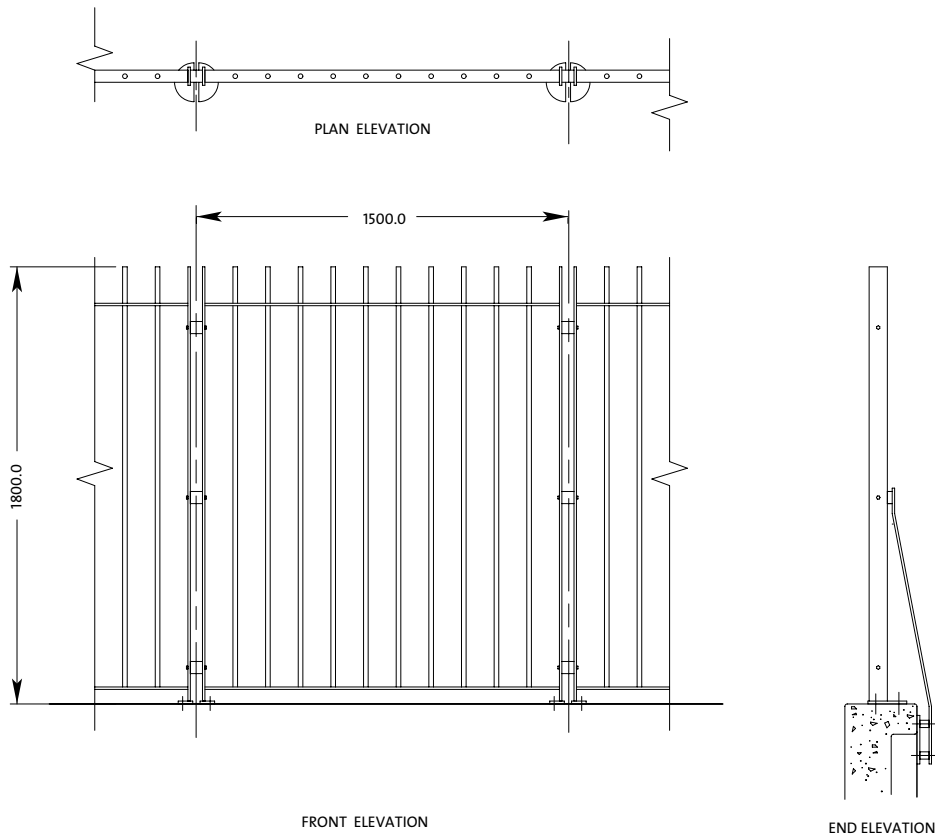

**Material/Finish**

- Mild steel hot dip galvanised.

**Comments**

- Assembled from readily available simple components. To comply with BCA requirements.

**Placement**

- Refer to SOPA Fencing Strategy.

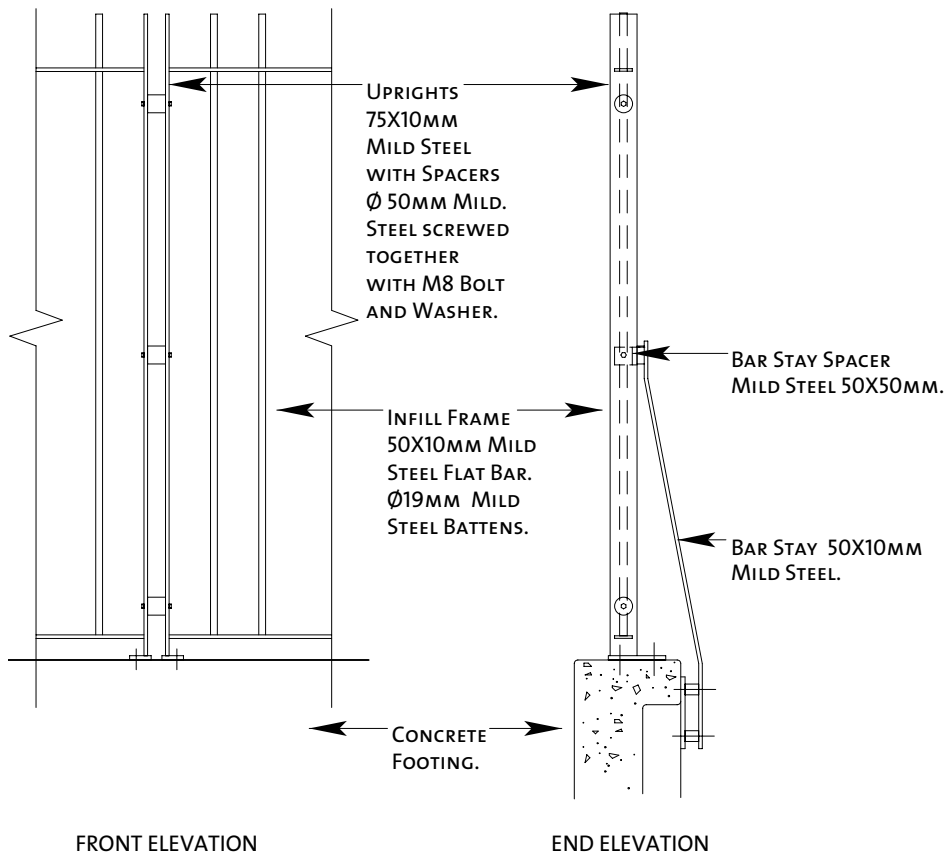

AR

**Principle**

High basic steel fence for use as required.

2009

Section 3.2  
Street Furniture

DESIGN INTENT ONLY

SF16



Flag-Pole



Material/Finish

- Tapered aluminium pole, clear anodised finish.
- Spun aluminium bullet top, anodised finish.

Comments

- In-ground or removable socket fixing.

Manufacturer's Details

Flagpole World  
42 Edwin Street  
Mortlake NSW 2137

Contact

Ph: (02) 9743 1111  
Fax: (02) 9743 5821

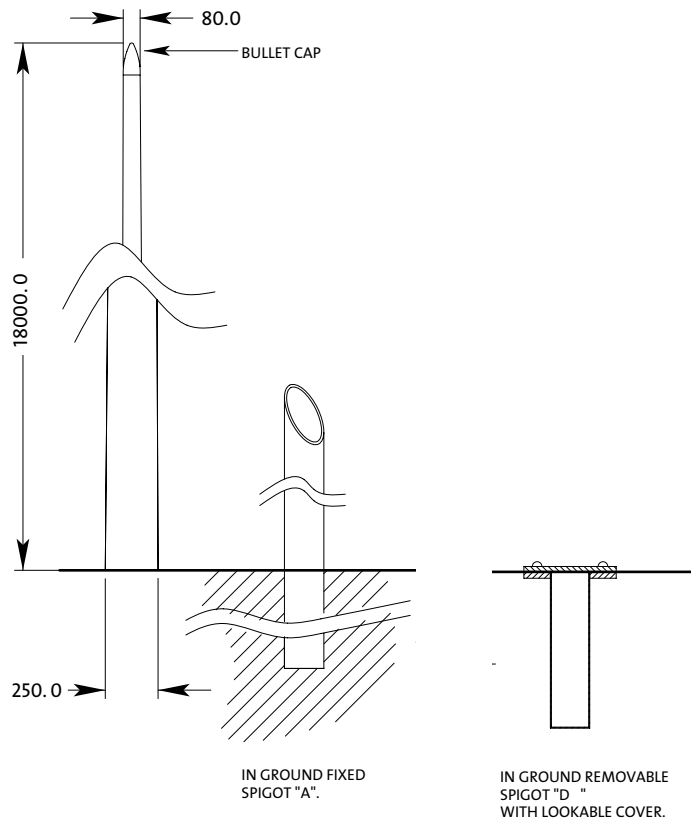

AR

Bus and Shade Shelter

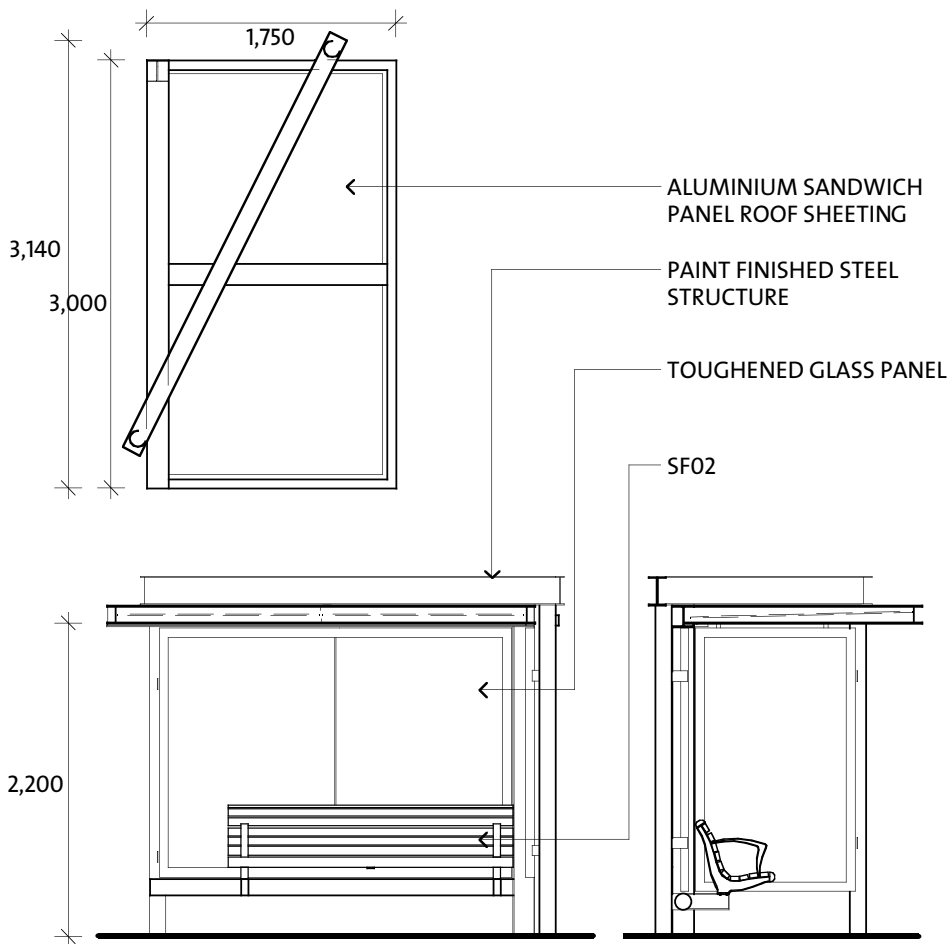

Material/Finish

- Steel frame paint finished with International Protective Coatings – colour equal to Dulux “Midnight Haze”.
- Roof sheet in Alucore aluminium sandwich panel – clear anodised finish.
- Seat – SF 02 with legs removed.
- Custom-made light fitting in galvanised steel to match existing on site.

Comments

- Install tactile ground surface indicators to comply with AS 1428.
- Refer details P21 and P22 for tactile ground surface indicators.

S8

S9

S10

S11

S15

S17

S18

Principle

Shelter for use as required.

2009

Section 3.2  
Street Furniture

DESIGN INTENT ONLY

SF18

**Avenue Plinth with  
Commemorative Plaque**



**Material/Finish**

- Precast concrete plinth with plaque.

**Comments**

- Assembled from readily available simple components.
- In areas of high pedestrian volumes locate plaque in pavement to eliminate obstacles to eliminate obstacles and retain maximum clear passage.
- Sealant and anti-graffitti coating on plinths.

**Manufacturer's Details**

Concrete Structures NZ

143 Riri Street  
PO Box 849  
Rotora  
New Zealand

**Contact**

Ph: (07) 347 8116  
Fax: (07) 346 1535

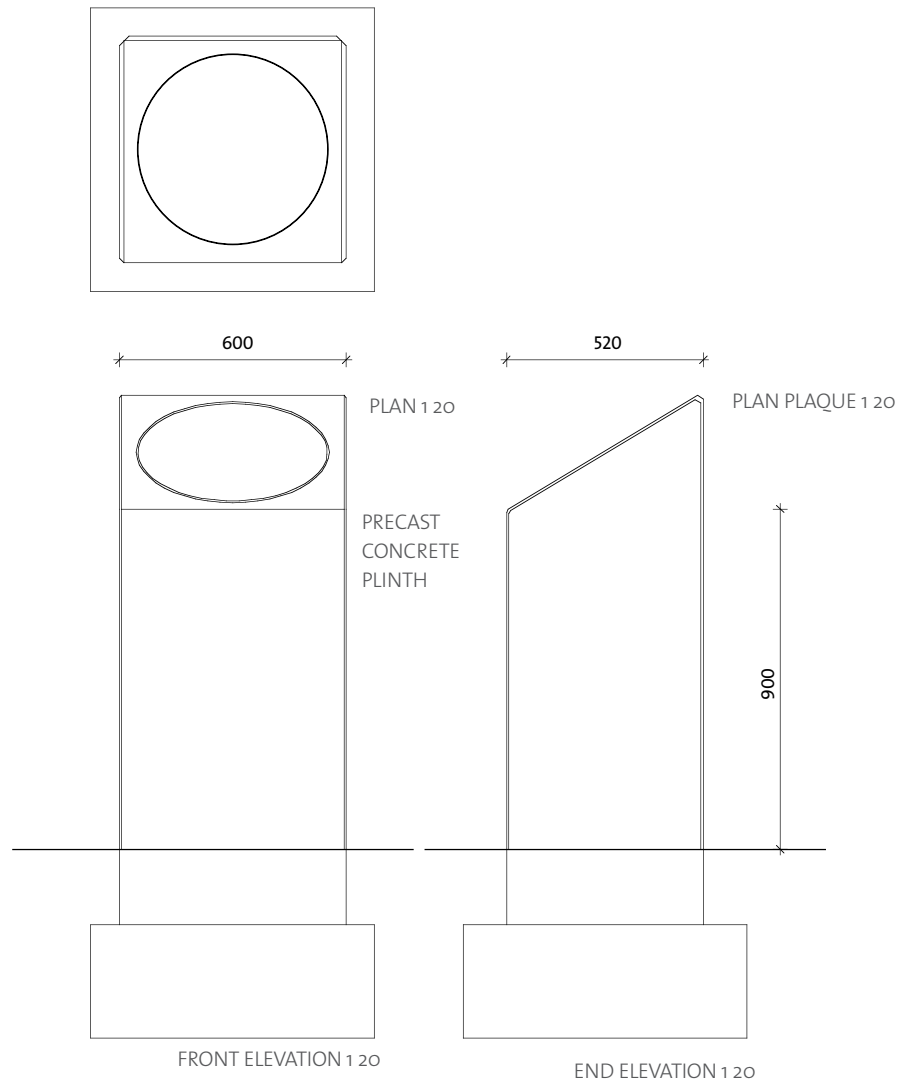

AR

**Bin Station**



**Material/Finish**

- SF38 Wall Type One.
- Matt finish anti-graffiti paint.
- Mild steel – galvanised.
- Backing Plates – powdercoated in Anzol Charcoal Metallic.
- Pictogram panels – refer to ?

**Comments**

- Utilises catalogue item 240L bins.
- Colour coded dark blue, maroon grey.

**Manufacturer's Details**

**Bin Locking Arm:**

Hore and Kenny  
12–14 Alexander Street  
Auburn NSW 2144

**Pictograms:**

Albert Smith Signs  
59 Taylor Street  
Bulimba QLD 4171

**Bins:**

Sulo MGB Australia Pty Ltd  
123 Wisemans Ferry Road  
Somersby NSW 2250

ELEMENT UNDER REVIEW

AR

**Principle**

Bin Station for renovation purposes only.

**2009**

**Section 3.2  
Street Furniture**

**DESIGN INTENT ONLY**

**SF24**



# Lighting

Urban Elements Design Manual  
Section

# 3.3

ISBN 978-0-9805976-1-5

© All rights reserved. No part of this work will be reproduced, translated, modified, transmitted or stored in any form by any means without the prior permission of Sydney Olympic Park Authority.

## 3.3 Lighting

### Lighting Design Strategy

#### Objectives

The objective for the Public Domain lighting is to create an inviting night time character, a night scene which compliments the environment.

This Lighting Design Strategy establishes the technical basis on which the detailed design of the Public Domain lighting is developed in order to meet this objective.

This Code has been developed recognising the scale of the site and the large number of structures within it. The Lighting Design Strategy considers the lighting in terms of scale, form, location, materials and integration of the lighting structures with the landscape, buildings and street furniture of the site.

**The following matters are outside the present scope of this Lighting Design Strategy:**

- cabling infrastructure;
- power reticulation to lighting, kiosks, vending machines and the like;
- provisions for communications, security or similar services; and
- traffic control signalling systems.

#### Strategies

The strategy in designing the lighting throughout the site is two-tiered. Core areas and peripheral areas of the site are identified, and secondly, their differing operation during the major events and non-event modes are addressed.

This Lighting Design Strategy sets out concepts which can be applied consistently throughout the site so that the overall effect of the lighting is harmonious. This includes the development of a “standard” range of luminaires and poles to be used throughout the site for road lighting, including the development of a unique “Sydney Olympic Park” pole design family, suitable for all pedestrian precincts.

#### Relevant Standards

This Lighting Design Strategy is to be read in conjunction with the latest edition of all relevant Australian Standards. Where Australian Standards do not exist, appropriate International Standards will apply. The applicable Standards include, but are not limited to the following:

AS/NZS 1158.0:2005 Lighting for Roads and Public Spaces: Introduction

AS/NZS 1158.1.1:2005 Lighting for Roads and Public Spaces. Part 1.1: Vehicular Traffic (Category V) Lighting – Performance and Design Requirements

AS/NZS 1158.3:2005 Lighting for Roads and Public Spaces. Part 3.1: Pedestrian area (Category P) lighting – Performance and Design Requirements

AS/NZS 1158.4:1987 Lighting for Roads and Public Spaces. Part 4: Supplementary Lighting at Pedestrian Crossings

AS 1428:2001 Design for Access and Mobility

AS 1798:1992 Lighting Poles and Bracket Arms

AS 3000:2000 SAA Wiring Rules

AS 3008:1998 Electrical Installations – Selection of Cables

AS/NZS 3827:1998 Lighting System Performance – Accuracies and Tolerances

AS 4282:1997 Control of the Obtrusive Effects of Outdoor Lighting

#### Installations

The installation of lighting on dedicated public roads will also meet the requirements of the local government authority, Auburn Council and Energy Australia. In developing the detailed lighting design, light spill from buildings should be minimised and external lighting provided under this Lighting Design Strategy must comply with the recommendations of AS 4282. (Note: existing lighting installations are not required to be modified to meet this provision.)

## Existing Lighting

As an overall objective, all remaining high and low pressure sodium lamps should be removed from the site and replaced with metal halide lamps with colour characteristics consistent with the lamps nominated in this Lighting Design Strategy.

## Lighting Tasks and Requirements

The lighting of the Sydney Olympic Park site has a multiplicity of purposes, however the fundamental criteria of site lighting are described below.

**Safety:** The systems must provide levels of light so that people can make their way around the site safely, feeling content to proceed along their intended route. Hazards such as intersections, crossings, changes of level and the like must be clearly visible.

**Orientation:** The lighting must provide visual guidance and a visual geometry for people so that they can see beyond their immediate location to reinforce their sense of direction and orientation. This is particularly important where people have entered a sporting facility by day and come out at night. The night environment should reinforce daytime features to establish orientation. Electronic and illuminated signage assists with the orientation. Illuminated signs should preferably be back lit.

**Security:** Lighting plays a major role in the security of people and property at night. The lighting must create an environment in which people feel they can see and be seen. Lighting is required for shade structures, bus shelters, amenities and telephone kiosks to ensure the security of the public. The lighting must be carefully integrated into the design of the structures, complimenting the quality of the detail applied to the Urban Elements generally. Highlighting preferred paths through the site may assist in concentrating night time pedestrian traffic. This can serve to improve security and create a more manageable situation for the security of staff.

**Pedestrians and Vehicles:** The lighting requirements where pedestrians and motor vehicle traffic are likely to mix are generally covered by Australian Standard AS/NZS 1158.0 and 1158.3.1, which describe several classifications based on use:

- Class V roads are heavily used major arterial or feeder roads, where the visual requirements of motorists are dominant;
- Class P roads are similar to residential streets, illuminated for pedestrians; and
- Class P roads are predominantly pedestrian pathways with limited vehicular activity.

The lighting should encourage vehicles to use the major avenues and create a visual environment in these locations that pedestrians will assume the likelihood of vehicular traffic.

Although the Lighting strategy recommends pole spacings for the various combinations of light fittings, lamps, mounting heights and outreach, these are indicative only and the lighting designer shall provide calculations complying with AS 1158 to demonstrate that the installation complies with the relevant light technical parameters.

## Night Environment

The lighting system must create a night time environment that is visually interesting and comfortable. The lighting system is to be co-ordinated with the signage to ensure efficient illumination and easy way-finding at night. The colour rendering and appearance of the light is critical to render skin tones, plants, owers and coloured materials in a pleasing manner. The lighting design for the Public Domain has to recognise that these are “people place” and that the comfort and atmosphere of the spaces are critical to their success and utilisation. The night imagery from viewing locations both inside and outside, and distant from the site should be included as part of the design process. New installations shall blend with the existing installations to maintain the visual cohesion of the park.

## Daytime Presence and Integration

The lighting systems are not purely a night time function, however. By day, the lighting structures will have a significant impact on the visual environment. The daytime appearance, scale and location of the lighting equipment should not compromise the photometric performance of the lighting design, but integrate well with all of the other elements of landscape and street furniture.

## Maintenance

Lighting fittings and ancillaries have been selected with consideration to ease of maintenance and replacement of parts, cleaning, security and vandal resistance. Standard fittings with proven reliability are required. Particular attention shall be paid to waterproofing uprights and lights in water features. Manufacturers' recommended installation and maintenance procedures must be documented for each type of assembly.

## Lamps

Metal halide light sources must be used throughout the site for consistency.

The colour temperature of lamps selected for the site for external lighting must fall in the range of 3,000°K to 4,000°K. The colour rendering index of lamps must be greater than 65. In high traffic pedestrian areas and at nightscape features, the Colour Rendering Index should be greater than 80. (Colour Rendering Group 1A or 1B.)

## Environmentally Sustainable Development

The environmentally sustainable aspects of the lighting design should embrace:

- energy efficient light sources and luminaires;
- flexible control systems;
- embodied energy and manufacturing attributes of lighting structures and components; and
- photovoltaic collectors to supplement the mains supply.

In wetlands, woodlands or particular areas where wildlife may nest, spilt light from the Public Domain must be minimised. Areas not accessible at night may not require lighting, except at the entrances. Areas where people are not encouraged to go at night may need to remain unlit.

## Photovoltaic Systems

There are existing photovoltaic systems incorporate throughout the park. Pylons along the Olympic Boulevard incorporate a system of panels which generate electricity back into the electricity mains by day and operate on the mains at night. While alternative power is encouraged and it is expected that there will be an initial cost premium, before incorporating into a design, all proposal should be submitted for approval with details of the initial cost, life expectancy and estimated energy and cost saving.

## Merging Lighting and Communications

Lighting in pedestrian areas may in part be dynamic in its output and lighting poles may have attachments which convey messages related to way-finding, safety, emergency directions, and the like. Lighting poles may also contain equipment which provides audio outputs for announcements or music, or which may respond to audible questions, or include sensors of various types. All lighting poles are to have a dedicated communications cable lead in conduit in addition to the power supply and provide segregation of power and communication cabling. This will allow any pole to provide both an input and or an output to a communication system.

## Lighting Controls

The ownership of the lighting will vary from road to road within the park and the surrounding areas. The control of the lighting will vary dependent on the owner of the equipment. The major area of the site is controlled by a centralised C-bus system. All lighting designated for duty during non-event periods should be time controlled, with a manual over-ride facility. Lighting for major events should be controlled in groups, one for each precinct. The lighting installation must include all control devices and interface equipment to allow the system to operate simply and economically. Where lighting is to be installed within the area covered by the site C-bus control system, the lighting shall be connected to this system.



The Sydney Olympic Park Authority will nominate the channel to be used. All contracts shall include for the reprogramming of the system to incorporate the new works. Particular consideration must be given to the control of special effect lighting integrated into the overall scheme and the two different levels of lighting required for major events and normal operation.

## Lighting Poles and Support Structure

Lighting poles and support structures are described in the Urban Elements Design Manual. Where the special Olympic Park Poles are used for street and pedestrian lighting fittings they must be supplied with allowance for ancillary services, signage and special fittings as described on the drawings. The pylon structures are a special feature and if more are required they the requirements will be specified. Pole spacings given in the technical schedules are maxima included to assist in the design process. They are not to be treated as a lighting design. The designer should calculate the spacing with consideration for the special requirements of intersections, crossings and landscaping and the requirements of the relevant standards.

## Olympic Plaza Lighting

The 30m pylons in Olympic Plaza not only illuminate the Plaza from the pylons, but also illuminate sections of the Boulevard adjacent to the Plaza. As an aesthetic feature, the pylons themselves are illuminated and contribute to the night imagery of the space.

Street Lighting in the Olympic Plaza Area: During “non-event” periods, the Boulevard roadway immediately adjacent Olympic Plaza will be lit to Category V3 requirements, as defined by AS/NZS 1158.0. The western side of the roadway is lit from luminaires mounted on the pylons, whilst the eastern side is illuminated from “Sydney Olympic Park standard” street lighting poles mounted beside the eastern footpath. During “event” modes, the Olympic Boulevard will be closed to traffic and the roadway will become a pedestrian thoroughfare.

During these periods, the lighting level on the roadway will be designed to Category P2 as defined by AS/NZS 1158.3. A similar approach will apply to the area between the Olympic Boulevard and the southern entry of Railway Station.

**Pedestrian Lighting:** The Plaza should be lit to Category P6 (as defined in AS/NZS 1158.3) in event mode and P7 in non-event mode.

**Pylon Feature Lighting:** The 30m pylons are a major contributor to the night image of Olympic Plaza and incorporate light sources within each pylon structure, a reactor assembly near the top and coloured spilt light to give night image form to the structures themselves. The pylons also incorporate solar energy collectors, which generate in parallel with the mains.

## Lighting of Places and Squares

These spaces will be illuminated to meet the requirement of Category P7 of AS/NZ 1158.3.1. Places and Squares will be lit with 7m poles carrying 70W metal halide fittings, spaced nominally at 15–20m. The arrangement must be developed in conjunction with the landscape and paving design. The Sydney Olympic Park standard poles carry provision for audio-visual equipment and effects, for example, television and security cameras, sound system equipment and special effect lighting fittings. The same facilities are to be provided in any supplementary poles.

## Road and Street Lighting

The light technical parameters for illuminating roadways and streets are defined by Australian Standard AS/NZ 1158, where lighting categories are assigned based on usage. The lighting categories should be confirmed by SOPA, based on their specialist advisors’ analysis of the site as a whole and its interface to the surrounding thoroughfares. The attached schedules forming part of this Manual provide a summary of the arrangement in principle for lighting each street.

### **Car Park Lighting**

AS/NZS 1158.3.1 recommends various lighting levels for car parks based on the night time occupancy rates. The occupancy rates will vary greatly depending on the events. Car parks that are adjacent to a venue should be illuminated to Category P11a while car parks that are more likely to be used as overflow for major events should be illuminated to Category P11c. Designated parking for people with disabilities should be illuminated to category P12. This should generally be achieved by co-ordination of the lighting locations and the carparking spaces. Homebush Standard pedestrian poles are the preferred method of lighting new car parks.

### **Lighting for Water Features**

There is no Australian Standard for the lighting of water features. Lighting designs for the water features will be developed as the water feature design progresses. Colour changing will be incorporated into the lighting design to add to the night imagery and visual interest of the water features. Particular care must be exercised to ensure the safety of people entering wet areas, whether or not such areas are intended to accommodate the public.

### **Lighting for Soft Landscaping and Parks**

There is no Australian Standard covering these areas, except where intersected by roads or pathways. The lighting design will take into account the planting and seek to give it relevant illumination in terms of colour, noting particularly colours of flowers and the creation of night images by direct or silhouette lighting techniques. Attention is required to reinforce pedestrian pathways and allow ready vision into parks and forests.

### **Procurement**

Procurement of urban elements must comply with the NSW Government's procurement policies.

Light Pole Plan

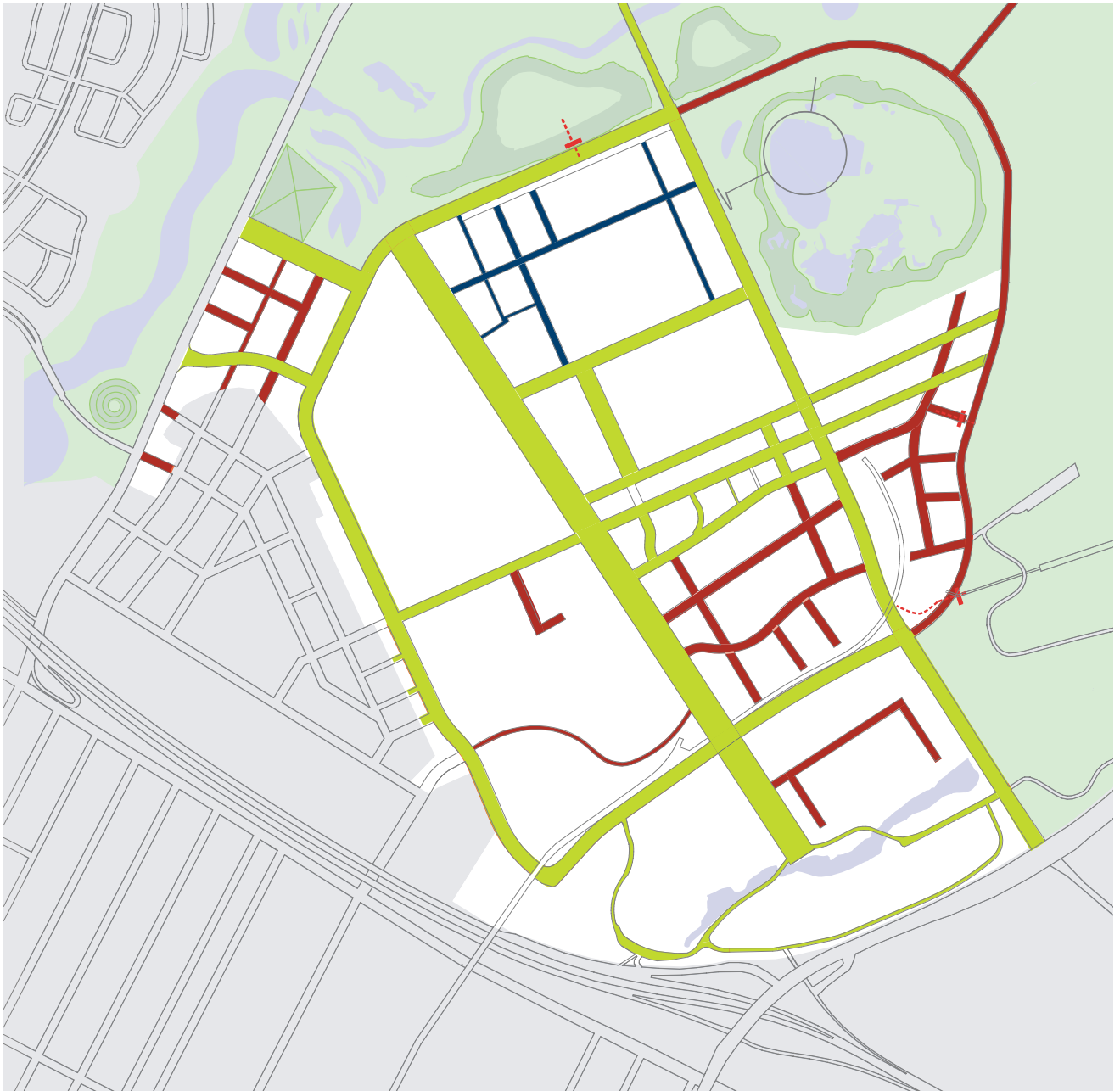

Light Pole Locations

Note: Refer Table LA3 for details

-  Custom Sydney Olympic Park Pole L2, L3, L4, L5, L6, L7
-  Pole 8, 8a, 8b, 8c, 8d
-  Special Showground Pole 9
-  Multi-function Pole L9

Light – Type 2

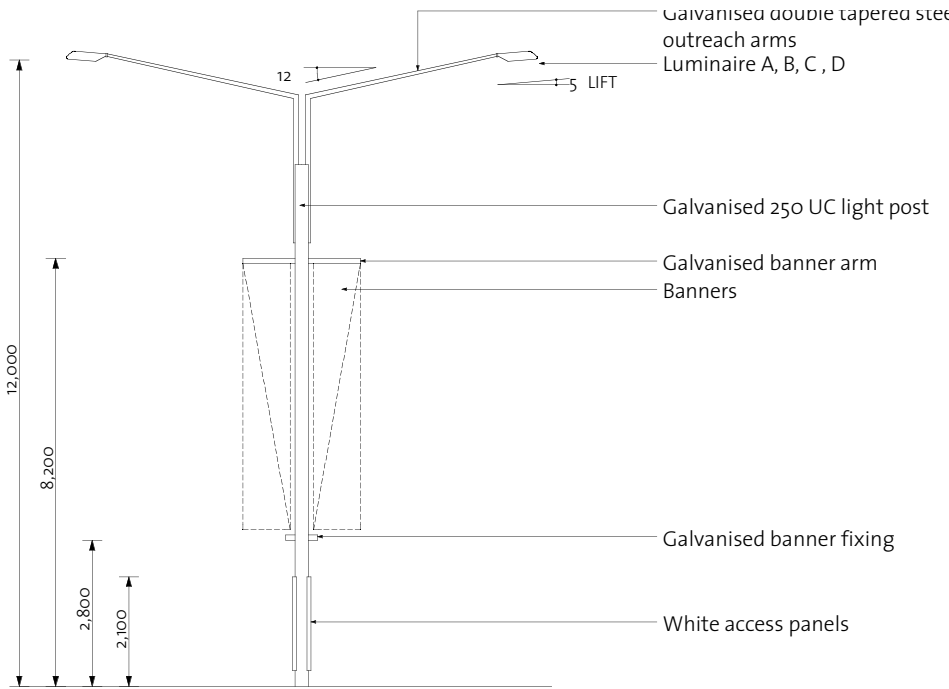

ELEVATION

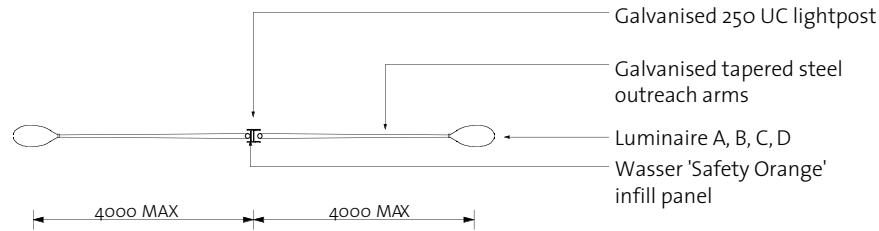

PLAN

Light – Type 3

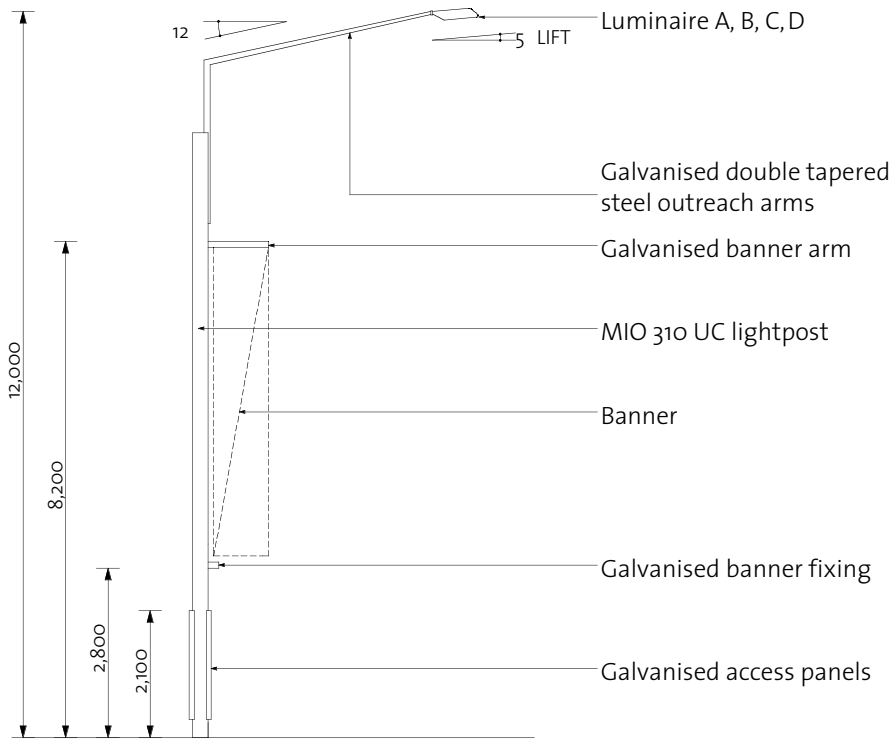

ELEVATION

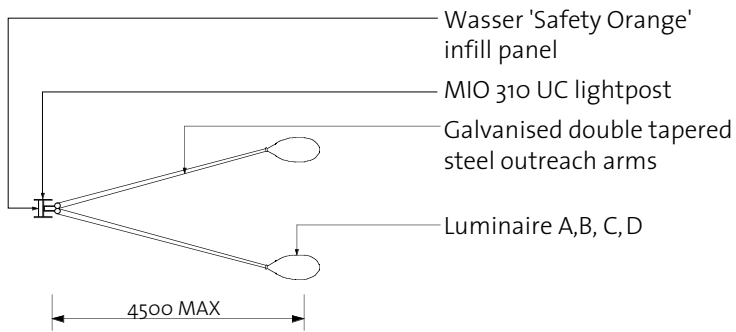

PLAN

Principle

Ceremonial fixture, two luminance levels as existing.

2008

Section 3.3  
Lighting

DESIGN INTENT ONLY

Light – Type 4

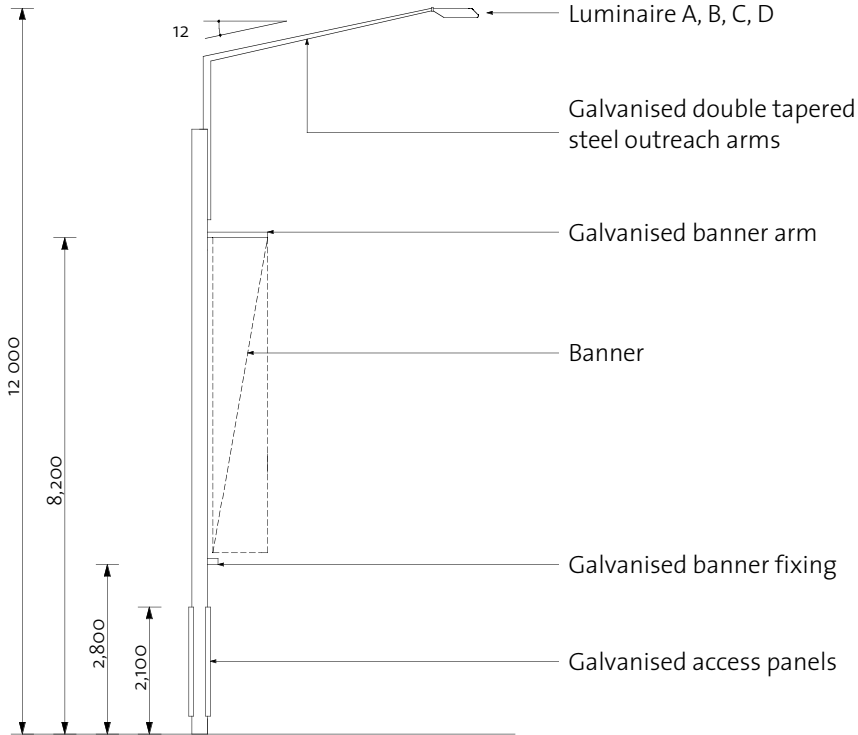

ELEVATION

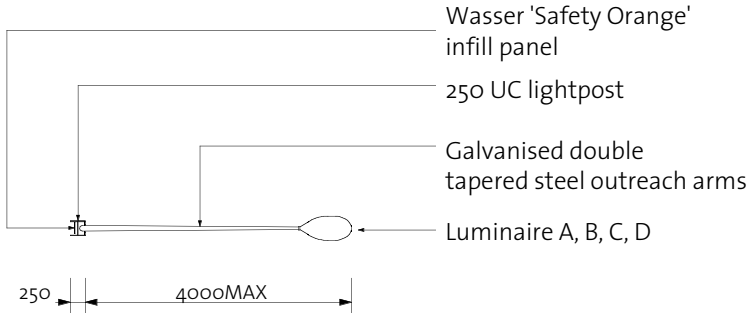

PLAN

Light – Type 5

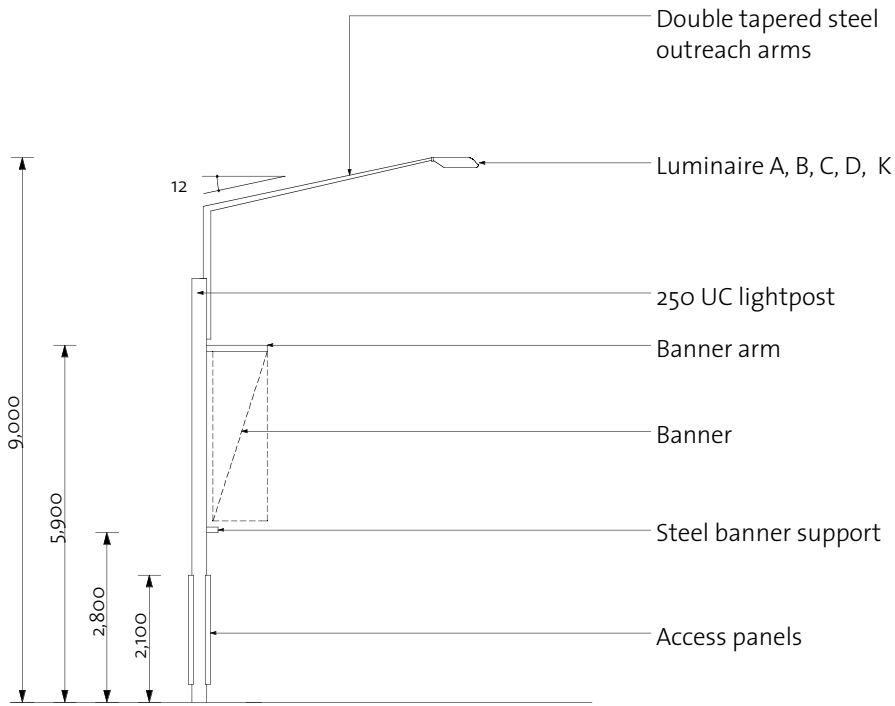

ELEVATION

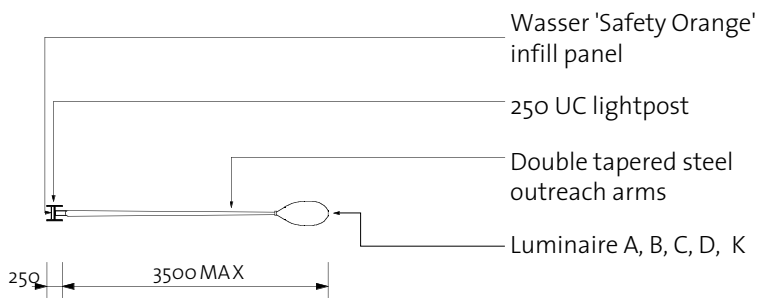

PLAN



Principle

9m pole for double-sided arrangement as existing.

2008

Section 3.3 Lighting

DESIGN INTENT ONLY

Light – Type 6

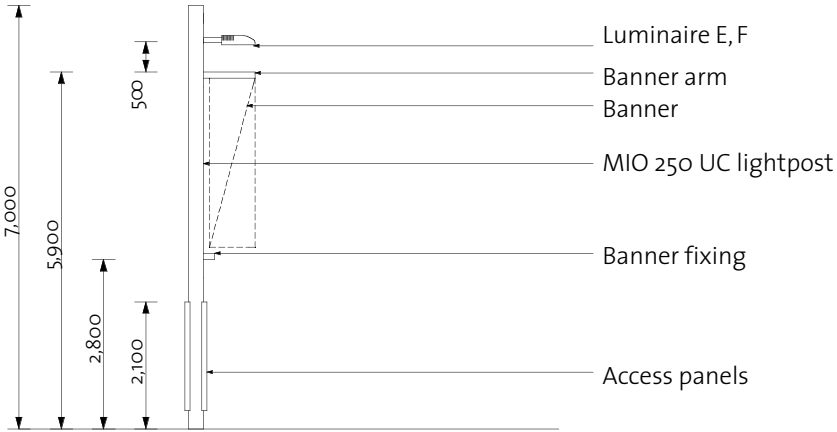

ELEVATION

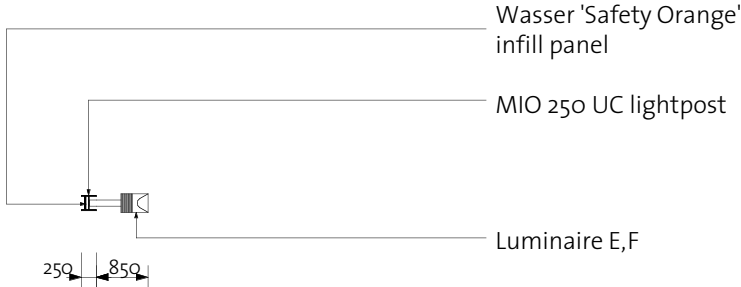

PLAN



Light – Type 7

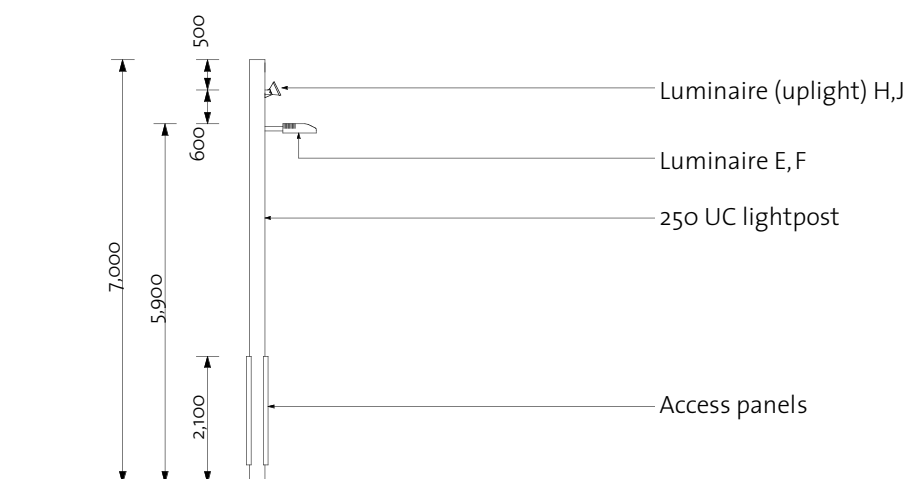

ELEVATION

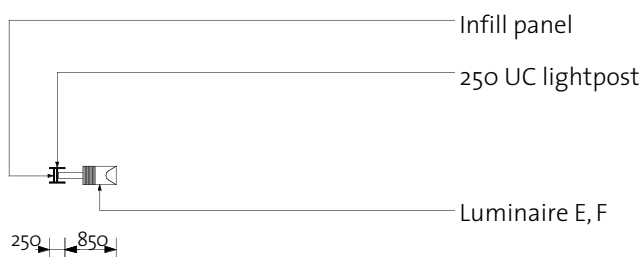

PLAN

**Principle**

For use on custom designed light poles as existing.

2008

Section 3.3  
Lighting

DESIGN INTENT ONLY

Light – Type 8

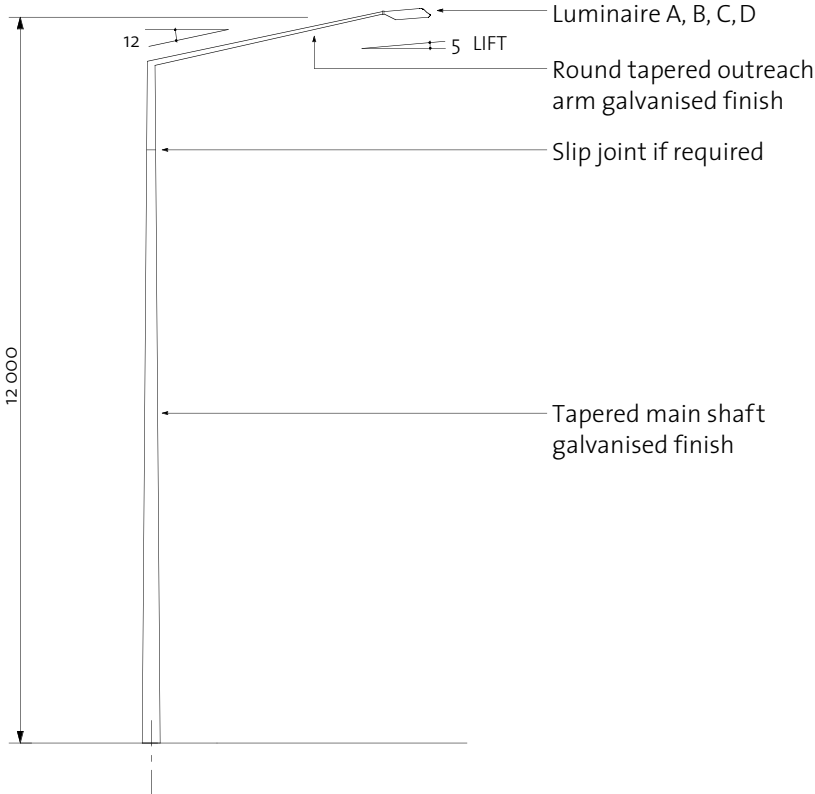

ELEVATION

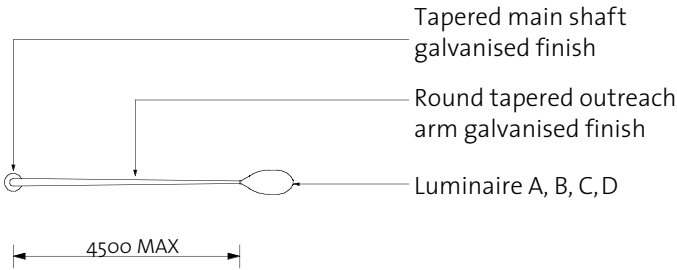

PLAN

Light – Type 8a

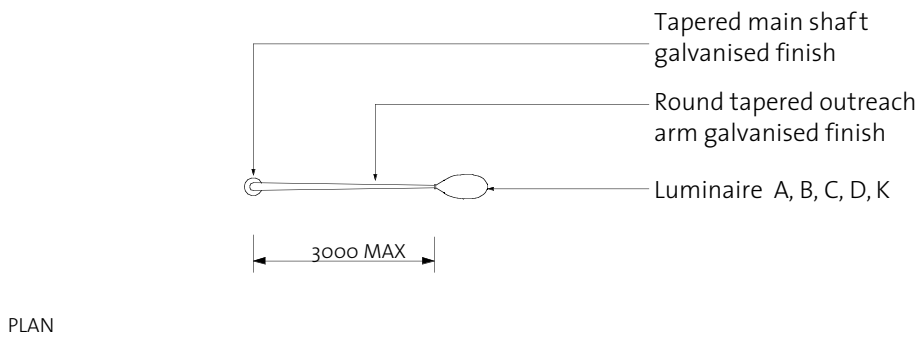
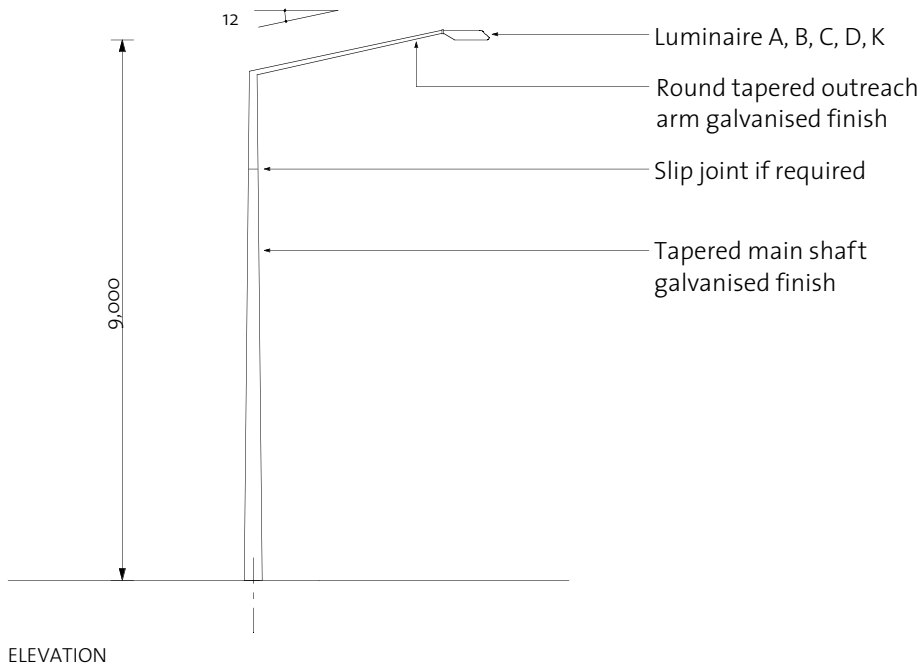

Principle

Standard pole for peripheral roads.

2008

Section 3.3  
Lighting

DESIGN INTENT ONLY

L8A

Light – Type 8b

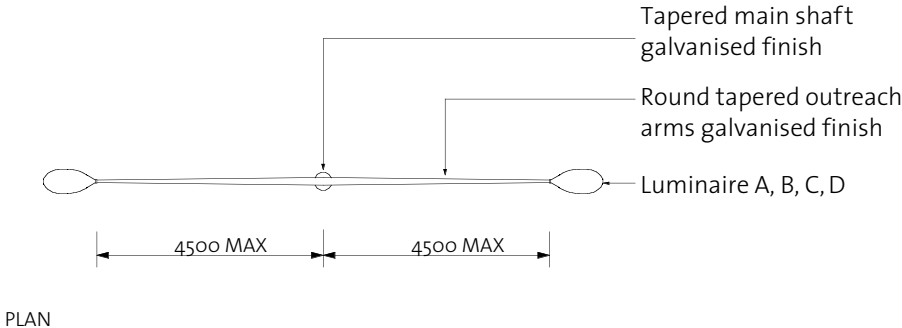
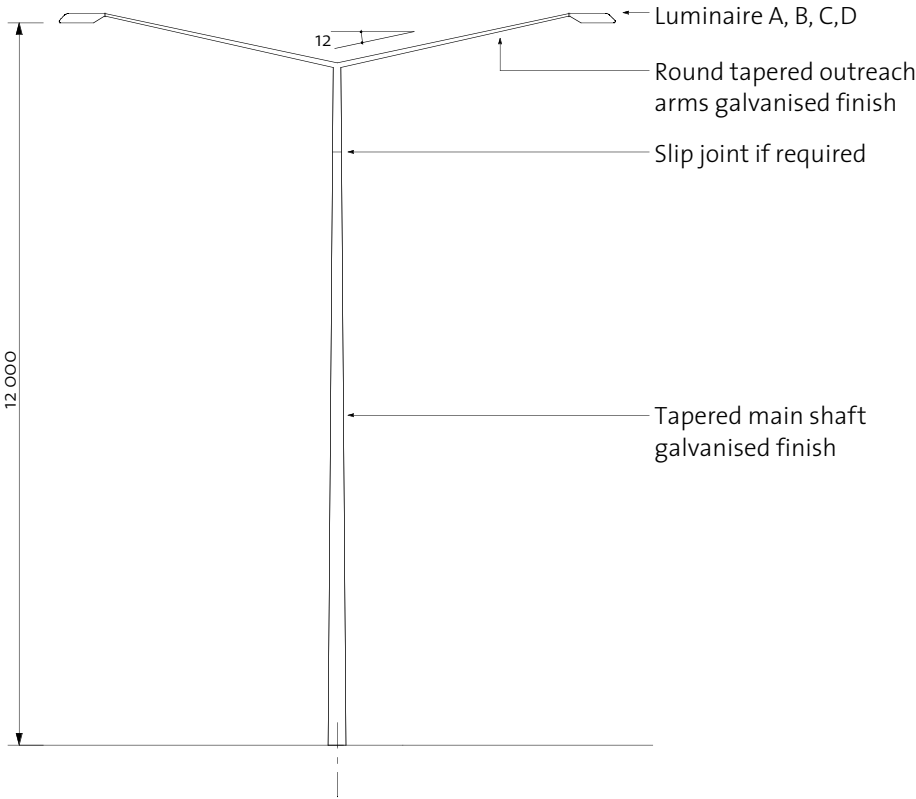

Light – Type 8c

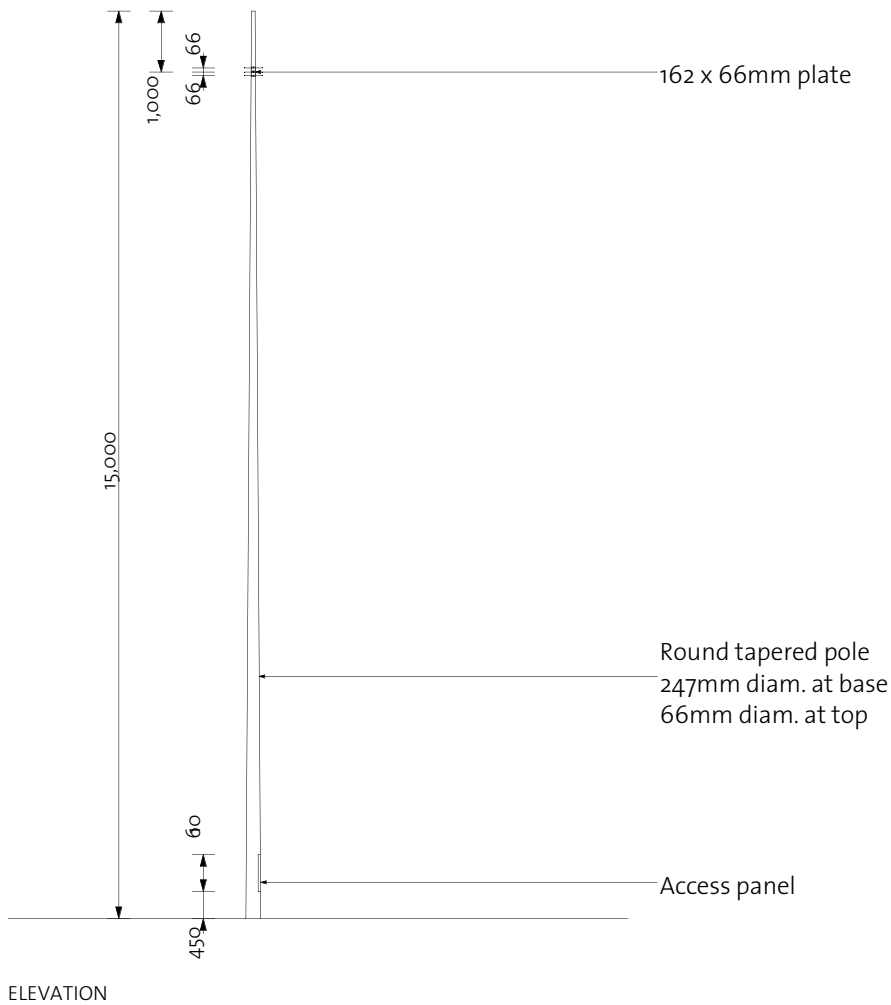

Principle

Standard pole for car parks.

2008

Section 3.3  
Lighting

DESIGN INTENT ONLY

L8c

Light – Type 8d

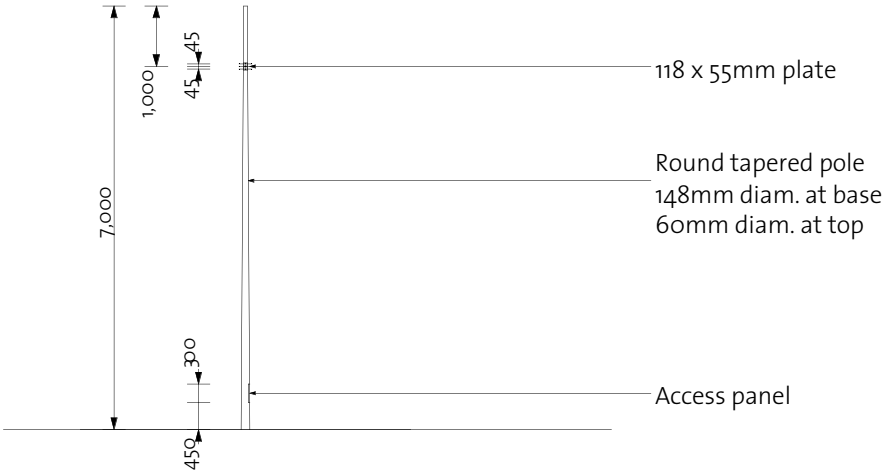

ELEVATION

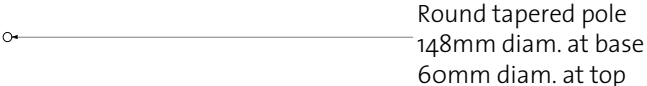

PLAN

Light – Type 9

Multi Function Pole

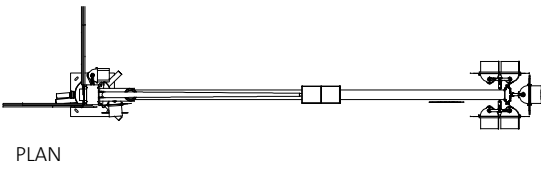
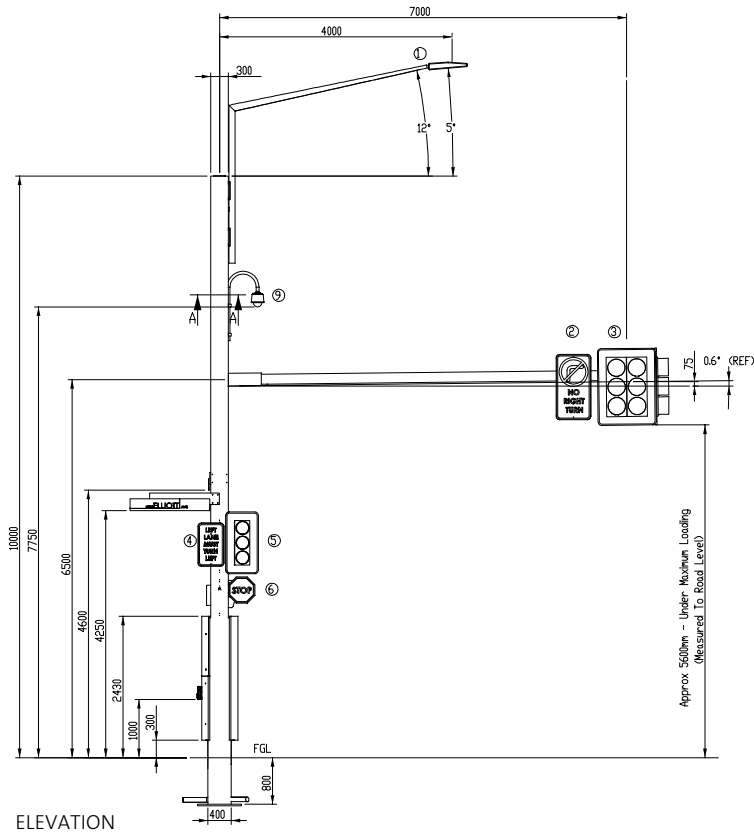

Principle

Standard pole for signalised intersections.

2008

Section 3.3  
Lighting

DESIGN INTENT ONLY

Light – Type 9a

Multi Function Pole – No Outreach

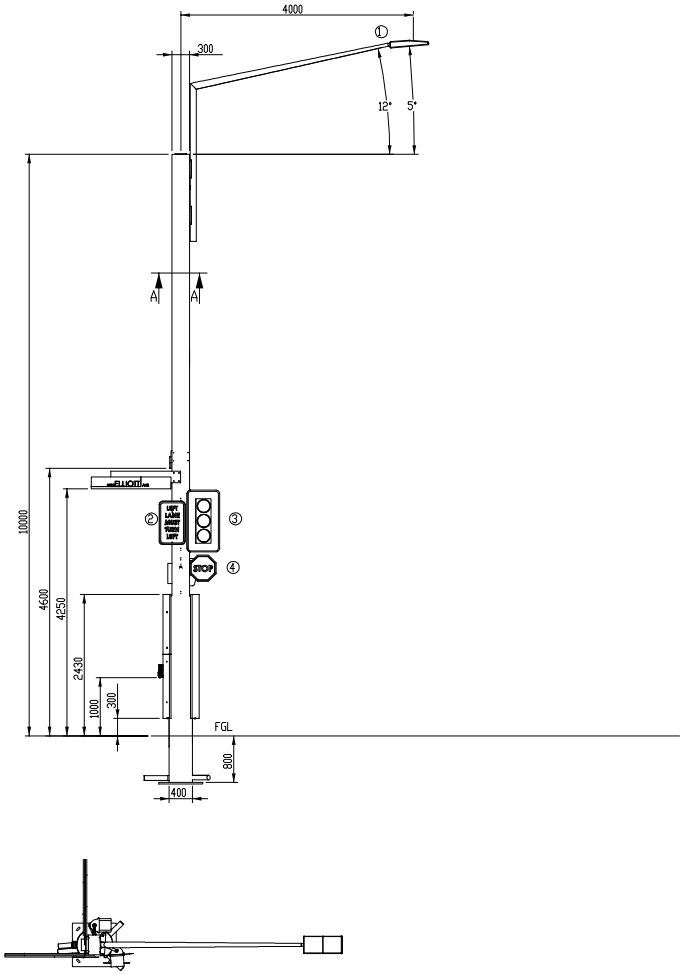

DESIGN INTENT ONLY

L9A

2008

Section 3.3 Lighting

Principle

Standard pole for signalised intersections.



Luminaire Table 1

**Sydney Olympic Park**  
Standard Luminaires (LED LUMINAIRES)

Road and area lighting

Luminaire Code	Description	Manufacturer	Supplier	Model	Typical Lamp Wattage (Note 1)	Distribution	Control Gear	Finish	Applications	Remarks
LaL	General Street Luminaire	Philips		xCeed	64 Watt LED	Standard	Integral	Grey	Pole L2	
		Philips			3000K	Australian Street			Pole L3	
LbL	General Street Luminaire	Philips		IP66	>80 CRI	Standard	IP24		Pole L4	
		Philips		xCeed	90 Watt LED	Australian Street	Integral	Grey	Pole L2	
LeL	Pedestrian Light	WE-EF		IP66	3000K		IP24		Pole L3	
		Light Culture		PFL	>80 CRI	Side throw	Integral	Black	Pole L6	
LfL	Coach parking Luminaires Area Luminaire	WE-EF		Aeroscreen	48 Watt LED	S60			Pole L7	
		Light Culture		IP66	3000K	Forward Throw				
Lg	Coach parking Luminaires Area Luminaire	WE-EF		IP66	72 Watt LED	Side throw	Integral	Black	Pole L8c	
		Light Culture		Aeroscreen	3000K	S60				
Lk1	Pedestrian Crossing Light	KIM		IP66	>80 CRI	Forward Throw				
		International Lighting		ArchWyle	400 Watt Metal Halide	Side throw	Integral	Black	Pole L8c	
Lk1	Pedestrian Crossing Light	Sienco		SiCompact	>70 CRI	Type 2				
		International Lighting		A1 Midi	400 Watt Metal Halide	Planar	Integral	Black	Pole L5	
				IP65	3200K	File to suit distribution			Pole L8a	

Notes

- 1 The Wattage may be varied to improve the energy efficiency while still achieving the specified lighting criteria requirements
- 2 Lg and Lk1 fittings are unchanged pending further development in LED floodlights

Luminaire Table 2

Sydney Olympic Park Standard Luminaires (LED LUMINAIRES)											
Landscape and Architectural Lighting											
Luminaire Code	Description	Manufacturer	Model	Lamp Wattage	Distribution	Control Gear	Finish	Applications	Remarks		
		Supplier		Lamp Type Colour Temperature Colour Rendering Index	Photometric File		Fitting				
LhL1	Landscape and Architectural Spotlight	We-ef Light Culture		FLC131	Narrow, medium, Wide and Linear Spread lens as required	In base	Black	Pole L6 Pole L7 Pole L8c			
				IP66	>80 CRI						
				FLC141	36-48 Watt LED 3000K	Narrow, medium, Wide and Linear Spread lens as required	In base	Black	Pole L6 Pole L7 Pole L8c		
LhL2	Landscape and Architectural Spotlight	We-ef Light Culture		IP66	>80 CRI						
				FLC240	150W Watt Metal halide 3000K	Narrow, medium, Wide and Linear Spread lens as required	Integral	Black	Pole L8d Pole L6 Pole L7 Pole L8c		
				IP66	>80 CRI						
Lj1	Landscape and Architectural Spotlight	We-ef Light Culture		FLC240	Narrow, medium, Wide and Linear Spread lens as required	Integral	Black	Pole L8d Pole L6 Pole L7 Pole L8c			
				IP66	>80 CRI						
				FLC240	250W Watt Metal Halide HQI TS 3000K	Narrow, medium, Wide and Linear Spread lens as required	Integral	Black	Pole L8d Pole L6 Pole L7 Pole L8c		
Lj2	Landscape and Architectural Spotlight	We-ef Light Culture		IP66	>80 CRI						
				ETC100/300	12W-36W Watt LED 3000K	Narrow, medium, Linear Spread, Asymmetrical as required	Integral	Stainless Steel face Plate	Uplighting trees wall washing sculpture lighting		
				IP67	>80 CRI						
LlL1	Inground Uplight	We-ef Light Culture		ETC100/300	Narrow, medium, Linear Spread, Asymmetrical as required	Integral	Stainless Steel face Plate	Uplighting trees wall washing sculpture lighting			
				IP67	>80 CRI						
				ETC100/300	12W-36W Watt LED 3000K	Narrow, medium, Linear Spread, Asymmetrical as required	Integral	Stainless Steel face Plate	Uplighting trees wall washing sculpture lighting		

NOTE

1 The Wattage may be varied to improve the energy efficiency while still achieving the specified lighting criteria requirements  
 2 Lj fittings are unchanged pending further development in LED floodlights

**Sydney Olympic Park**  
Road Lighting Classification ( LED LUMINAIRES)

Ver 3 - 16 Feb 2016

Street Types	Street Name	Lighting Category (Normal Operation)	Lighting Category (Event Operation)	Pole Type	Luminaire Type	Nominal Luminaire Power (Note 4)	Mounting Height	Outreach	Arrangement	Typical Maximum Spacing (Refer Note 1)	Preferred spacing	Notes
<b>Civic Streets</b>												
1	Olympic Boulevard North	V3	V1	L3	2 x LaL	90	2	4.5	SS		60	2
				L6/L7	LeL	48	6.4	0.85	AR	As Required		2
2	Olympic Boulevard South	V3	V1	L3	LaL	90	12	4.5	OP		60	2
				L6/L7	LeL	48	6.4	0.85	AR	As Required		2
3	Dawn Frazer Ave East	V5	V3	L4	LaL	90	12	4	SS	55	32	
4	Dawn Frazer Ave Station	V5	V3	L4	LaL	90	12	4	SS	55	32	2
5	Dawn Frazer Ave West	V5		L4	LaL	90	12	4	SS	33	32	
6	Murry Rose Ave East	V5		L4	LaL	90	12	4	SS	44	32	
7	Murry Rose Ave Station	V5	V3	L4	LaL	90	12	4	SS	64	32	2
<b>PerimeterAvenues</b>												
8	Australia Ave	V3		L2	LbL	155	12	4	M	56	50	
				L4	LbL	155	12	4	OP	55	50	
				L6/L7	LeL	48	6.4	0.85	AR	As Required		
9	Kevin Coombs Ave	V3		L2	LbL	155	12	4	M	56	50	
				L4	LbL	155	12	4	OP	55	50	
				L6/L7	LeL	48	6.4	0.85	AR	As Required		
10	Edwin Flack Ave	V3		L2	LbL	155	12	4	M	56	50	
				L4	LbL	155	12	4	OP	55	50	
				L6/L7	LeL	48	6.4	0.85	AR	As Required		
11	Sarah Durack Ave	V3		L2	LbL	155	12	4	M	56	50	
				L4	LbL	155	12	4	OP	55	50	
				L6/L7	LeL	48	6.4	0.85	AR	AsRequired		
12	Holker St	V3		L8	LbL	155	9	3	SS		32	
				L8	LbL	155	9	3	OP		30	
13	Pondage Link	V3		L2	LbL	155	12	4	M			Existing
14	Old HillRoad	V3		L2	LbL	155	12	4	M			Existing
<b>Town Streets</b>												
15	Herb ElliottAve	V5		L8a	LaL	90	9	3.5	ST	32	24	
16	Campus Walk	P3- no vertical		L8d	LeL	48	6.4	0.85	SS	41	35	
17	Showground Road	V5	V3	L5	LaL	90	9	3.5	SS	25	25	road reserveonly
		P3							SS	40		road reserveonly
18	Grand Parade	V5	V3	L6/L7	LeL	48	6.4	0.85	AR	AsRequired		Verge
				L4	LbL	105	12	4	OP	55	50	
<b>Local Streets</b>												
19	Median Street	P3 - no vertical		L8d	LeL	48	6.4	0.85	SS	40	35	
20	Figtree Ave	V5		L5	LaL	90	9	3.5	ST		25	Existing
21	Verge Street	P3 - no vertical		L8d	LeL	48	6.4	0.85	SS	16		
22	Pedestrian Street	P3		L8a	LaL	90	9	3.5	SS	36		
23	Shared Way	P4		L8d	LeL	48	6.4	0.85	SS	21		
24	CarParking Street	P2		L8d	LeL	48	6.4	0.85	SS	25-29	25	
25	Coach Parking Street	P2		L8a	LaL	90	9	3.5	ST	21	20	
26	Paved Street	P3 - no vertical		L6/L7	LeL	48	6.4	0.85	ST	21	20	
									2	21	20	4
27	Showground Street	P3 - novertical		L6/L7	LeL	48	6.4	0.85	SS	6		Existing
									SS	29		Existing
<b>Park Edge Streets</b>												
28	Bennelong Road	V5		L8	LaL	90	12	4.5	SS	46		
				LbL	155	12	4.5	SS	59			
29	Marjorie JacksonParkway	V5		L8	LaL	90	12	4.5	SS	46		
				LbL	155	12	4.5	SS	59			
30	Shirley Strickland Ave/ Rod LaverAve	P4		L6/L7	LeL	48	6.4	0.85	SS	40-45	32	
31	Park Edge StreetFigtree	P4		L8d	LeL	48	6.4	0.85	SS	47	45	
32	Park Edge Street Haslam's	P4		L8d	LeL	48	6.4	0.85	SS	47	45	
33	Park Edge Street Golf	P3 with vertical		L8d	LeL	48	6.4	0.85	SS			
					LeL							
	Park Edge Street 1	P4		L8d	LeL	48	6.4	0.85	ST	49	45	
	Park Edge Street 2	P4		L8d	LeL	48	6.4	0.85	SS	47	45	
	Park Edge Street 3	P4		L8d	LeL	48	6.4	0.85	SS	46	45	

SS = Single Sided  
ST = Staggered  
OP = Opposite  
M = Median  
AR = As required

Notes  
1

Spacing information is provided to assist initial design. The lighting of the roads and paths should be designed to comply with AS1158 allowing for interseclions, curves, kerb entries, trees, street furniture and other local co-ordination issues.

- 2 Event lighting shall have the ability to reduce to a lower level in not event times either by dimming or switching part of the LED array
- 3 A Light Loss Factor/ Maintenance Factor of 0.7 shall be used in all calculations. The Nominal Luminaire Power is indicative only. The designer needs to confirm compliance with the relevant category in AS/NZS1158. TheWattage may be varied to improve the energy efficiency while still achieving the specified lighting category requirements.
- 4



# Engineering Elements

Urban Elements Design Manual  
Section

# 3.4

ISBN 978-0-9805976-1-5

© All rights reserved. No part of this work will be reproduced, translated, modified, transmitted or stored in any form by any means without the prior permission of Sydney Olympic Park Authority.

## 3.4 Engineering Elements

### Introduction

Engineering Elements within this section include kerbs, gutters, grates and service covers. These elements define pedestrian areas and incorporate the necessary drainage and utility functions.

### Objectives

A range of kerbs are used in different streets and pedestrian areas at Sydney Olympic Park to:

- express the street hierarchy
- visually define the footpath areas
- signify different levels of pedestrian and vehicular priorities
- direct water into the storm water system
- implement water sensitive urban design measures

### Relevant Standards

The paving strategy is to be read in conjunction with the latest edition of all relevant Australian Standards. Where Australian Standard do not exist, appropriate International Standards will apply.

Relevant Australian Standards include but are not limited to the following:

AS 2758 Aggregates and rock for engineering purposes

AS 1379 Specification and supply of concrete

AS 2876 Concrete kerbs and channels (gutters) –  
Manually or machine placed

AS 1428 Design for access and mobility

### Procurement

Procurement of urban elements must comply with the NSW Government's procurement policies.

**Typical Precast Kerb**

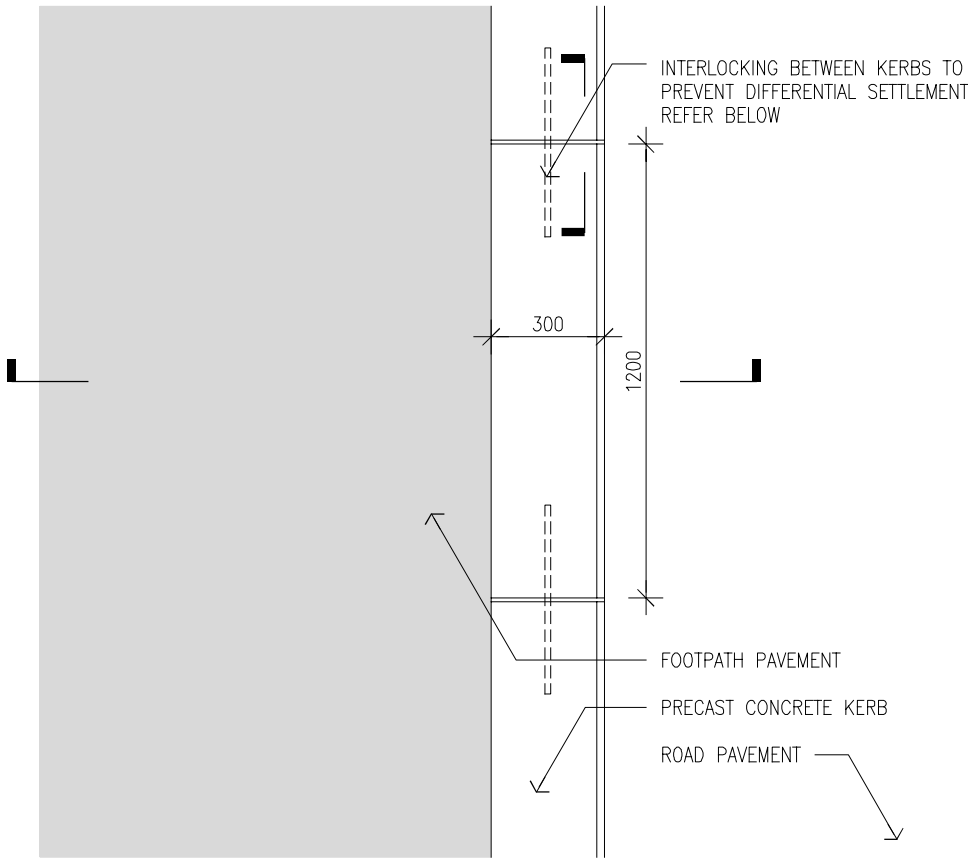

**Material**

- Precast concrete kerb 300mm width x 1200mm length.
- Strength – 20MPa.
- Large aggregate – Marrangaroo gravel or similar.
- Fine aggregate – washed river sand.
- Off-white cement.

**Finish**

- Acid etch finish.

**Construction**

- To engineers final specification.
- Placement and installation of kerbs to manufacturers specification.
- Recycled base material to engineers final specification.

PLAN

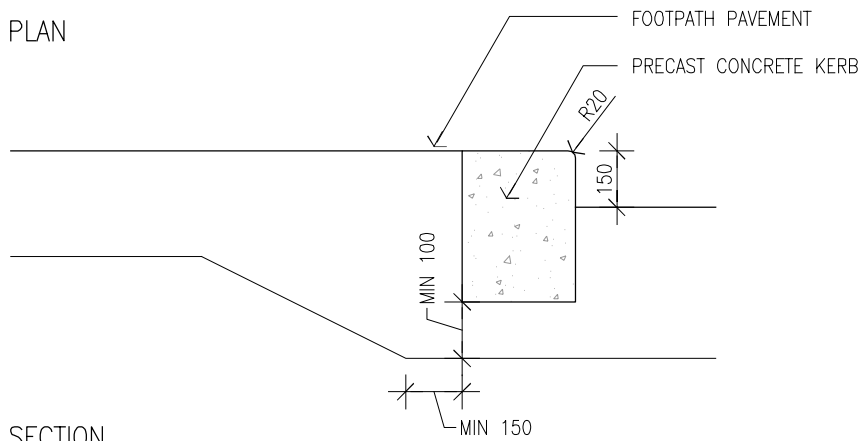

SECTION

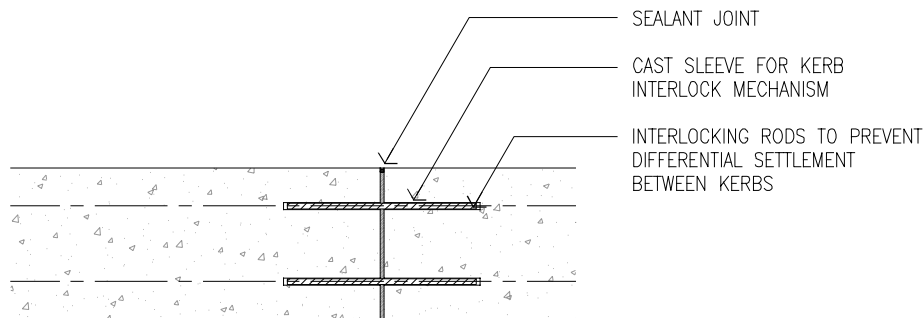

SECTION

S1 S2

**Principle**

High quality finish for use in Civic Streets.

2008

Section 3.4  
Engineering Elements

DESIGN INTENT ONLY

**2.3 Typical Precast Flush Kerb**



**Material**

- Precast concrete flush kerb 300mm width x 1200mm length.
- Strength – 20MPa.
- Large aggregate – Marrangaroo gravel or similar.
- Fine aggregate – washed river sand.
- Off-white cement.

**Finish**

- Acid etch finish.

**Construction**

- To engineers final specification.
- Placement and installation to manufacturers specification.
- Recycled base material to engineers final specification.
- Refer detail P21 for tactile ground surface indicators.
- Flush kerb to comply with AS1428 requirements.

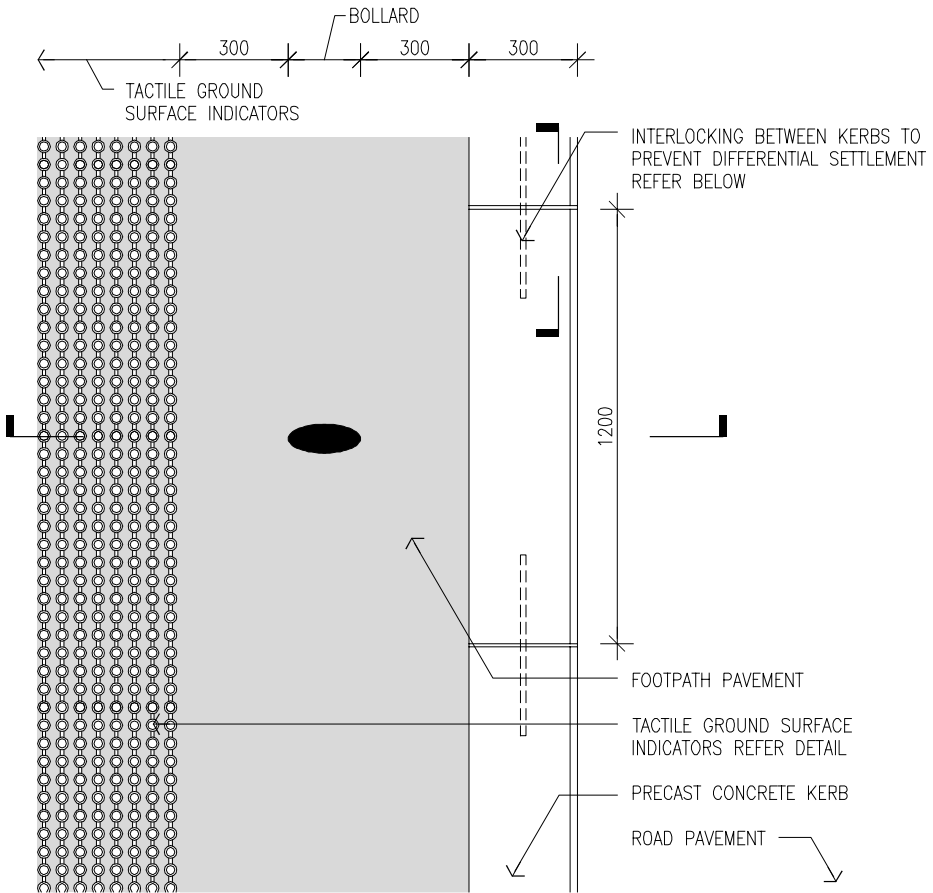

**PLAN**

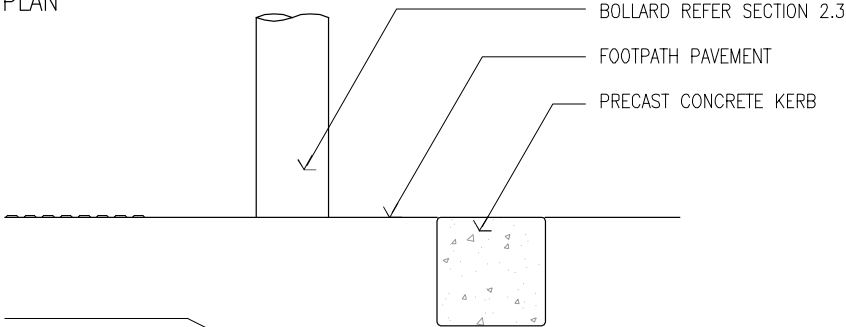

**SECTION**

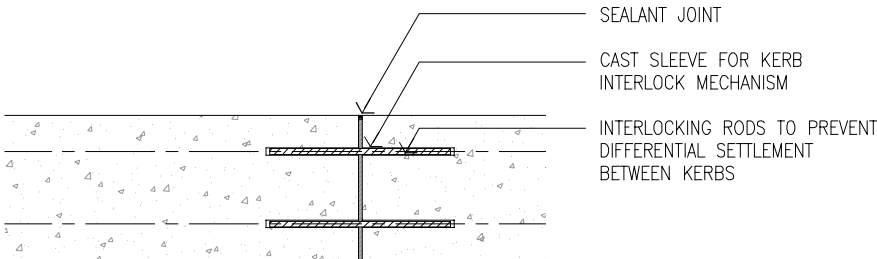

**SECTION**

S1

**Typical Insitu Kerb and Gutter Preferred Size**

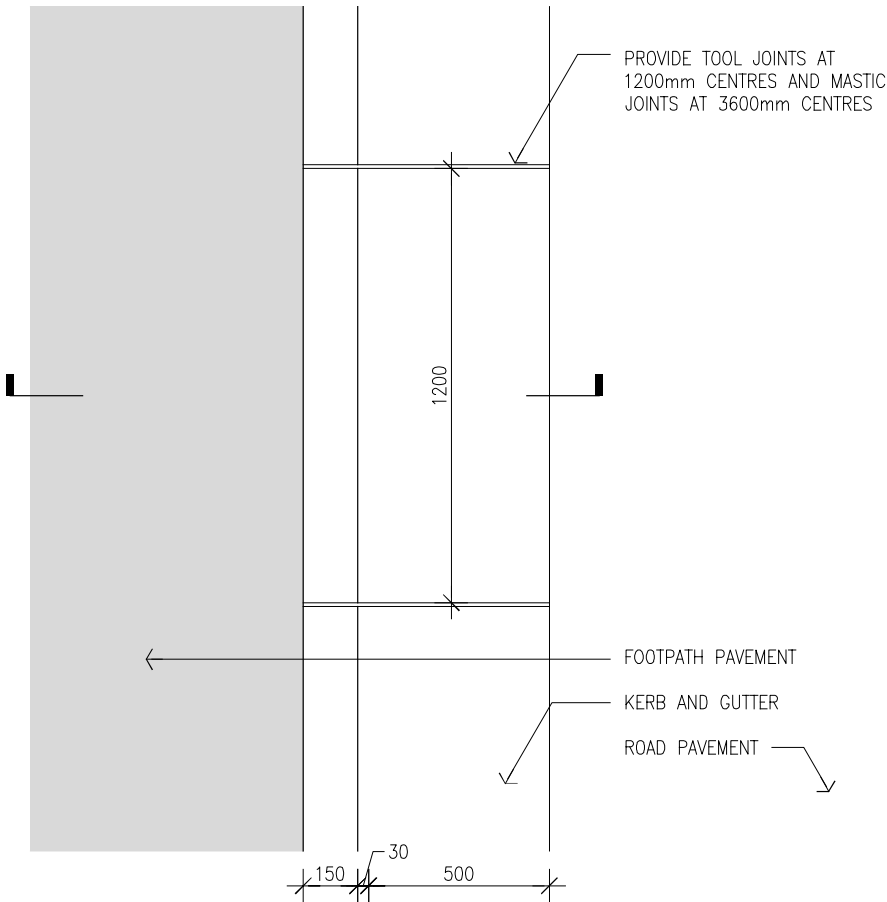

PLAN

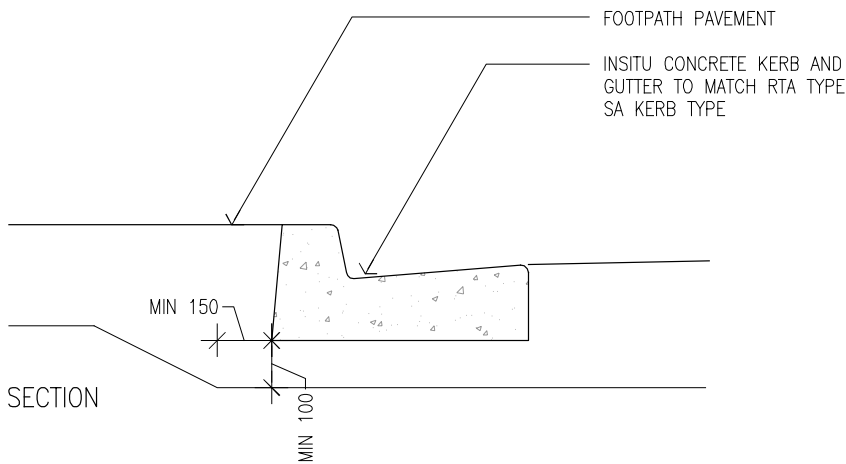

**Material**

- Insitu concrete kerb and gutter, (to match RTA SA kerb type).
- Strength – 20MPa.
- Standard concrete mix to match approved sample.

**Finish**

- Standard concrete finish.

**Construction**

- To engineers final specification.
- Tool joints at 1200mm centres.
- Mastic joints at 3600mm centres.
- Recycled base material to engineers final specification.

			S8	S9	S10
S11	S12	S13	S14	S19A	S19B
S20	S21A	S21B	S24	S25	S26
S28	S29	S30	S31	S32	S33

**Principle**  
Standard finish and dimension for secondary streets.

**2008**  
Section 3.4  
Engineering Elements

**DESIGN INTENT ONLY**



**Typical Insitu Concrete Kerb Large**



- Material**
- Insitu concrete kerb and gutter, 1200mm length nominal.
  - strength – 20MPa.
  - Standard concrete mix to match approved sample.
- Finish**
- Standard concrete finish.
- Construction**
- To engineers final specification.
  - Tool joints at 1200 centres.
  - Mastic joints at 3600mm centres.
  - Recycled base material to engineers final specification.

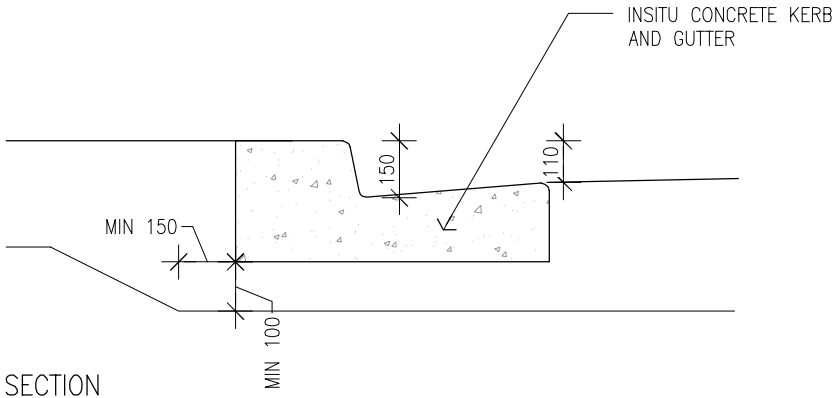
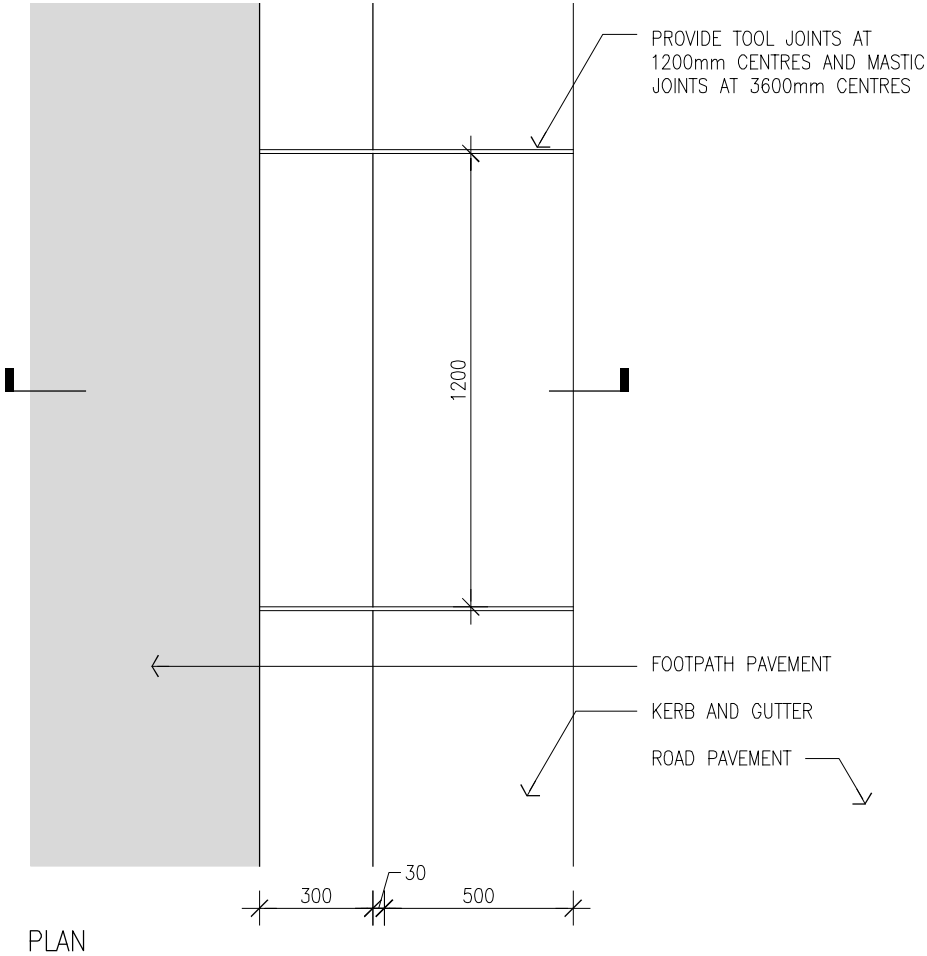

				S3	S4
S5	S6	S7	S15	S16A	S16B

DESIGN INTENT ONLY

E4

2008

Section 3.4 Engineering Elements

Principle

High quality finish, large scale for use in principal streets.

**Typical Insitu Swale**

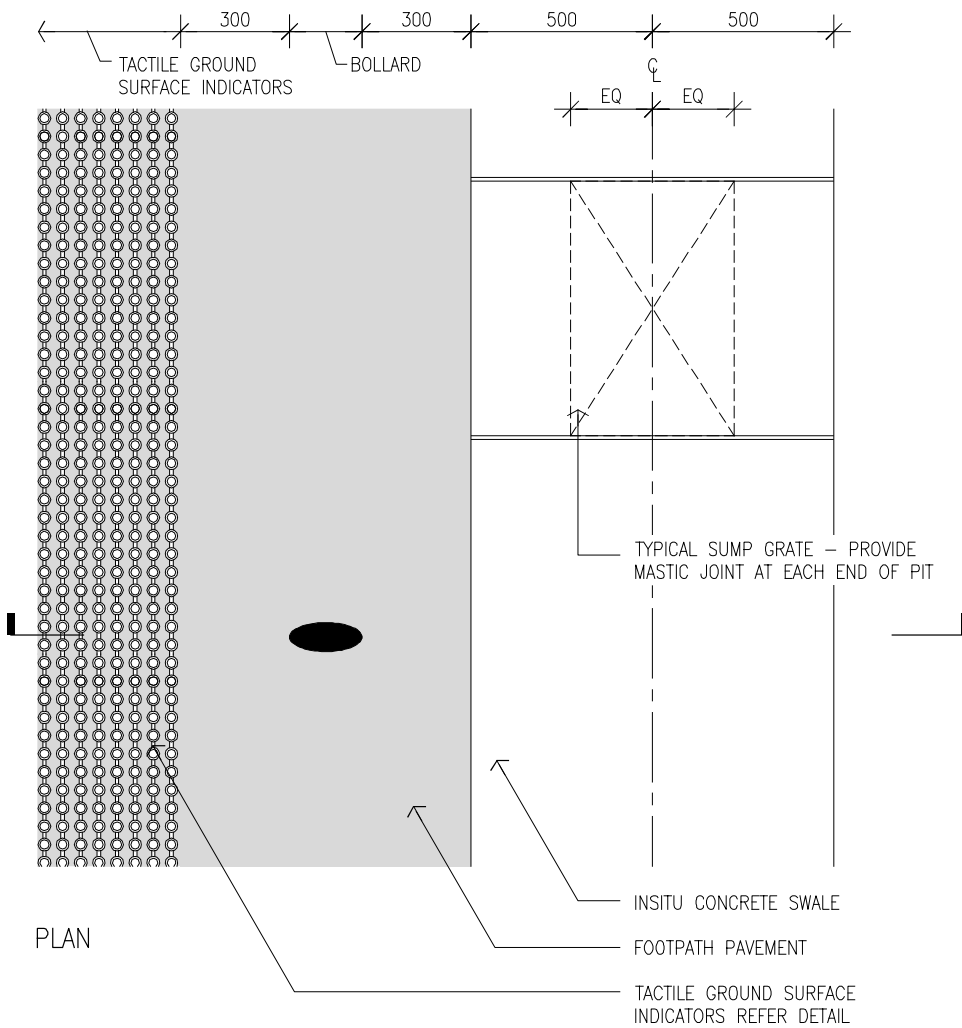

PLAN

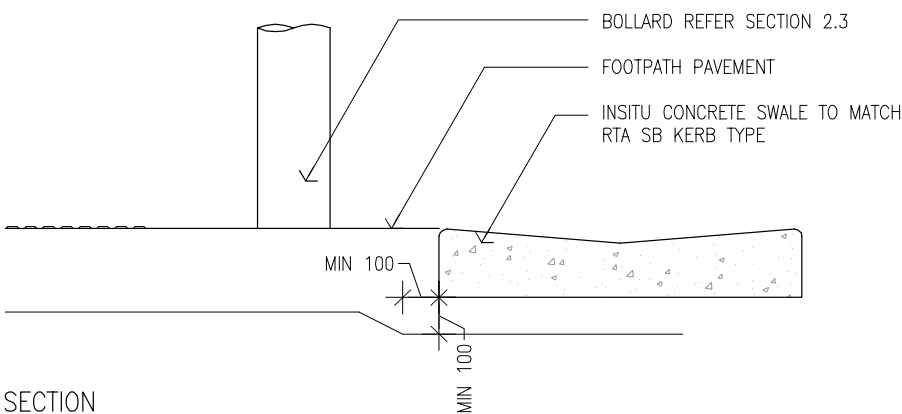

SECTION

**Material**

- Insitu concrete swale equal to RTA SB type.
- Strength – 20MPa.
- standard concrete mix.

**Finish**

- Standard concrete finish.

**Construction**

- To engineers final specification.
- Tool joints at 1200mm centres.
- Mastic joints at 3600mm centres.
- Recycled base material to engineers final specification.
- Refer detail P21 for tactile ground surface indicators.
- Insitu swale to comply with AS1428 requirements.

**Principle**

For drainage and to signal road edge where kerbs are not required.

**2008**

**Section 3.4 Engineering Elements**

**DESIGN INTENT ONLY**

**Typical Insitu Flush Kerb**



- Material**
- Insitu concrete 680mm width flush kerb, jointing 1200mm nominal.
  - Insitu concrete 800mm width flush kerb, jointing 1200mm nominal.
  - Strength – 20mpa.
  - Standard concrete mix.

- Finish**
- Standard concrete finish.

- Construction**
- To engineers final specification.
  - Tool joints at 1200mm centres.
  - Recycled base material to engineers final specification.
  - Refer detail P21 for tactile ground surface indicators.
  - Insitu swale to comply with AS 1428 requirements.

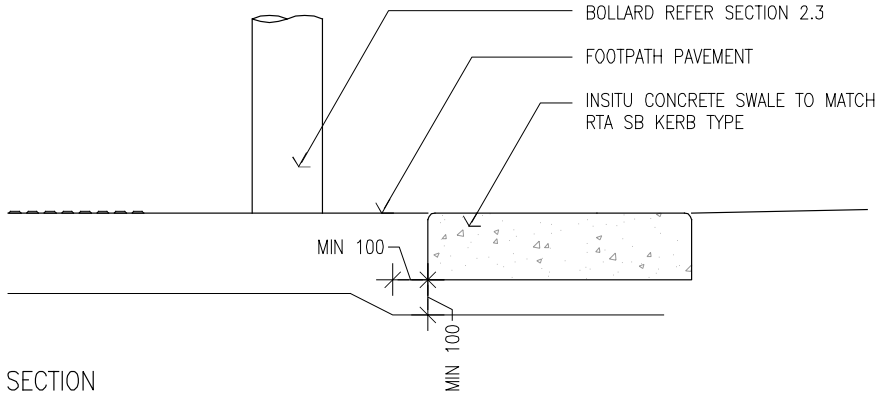
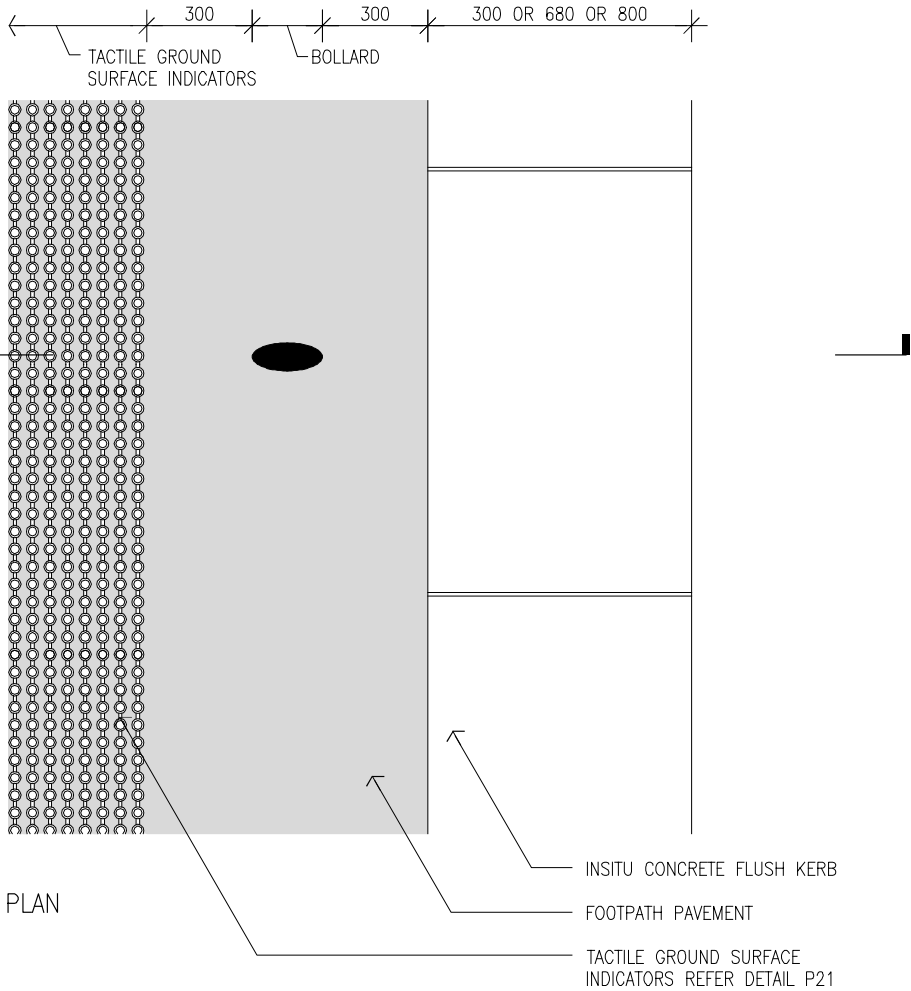

S17 S18

### Typical Permeable Kerb

**Material**

- In situ concrete flush kerb with starter bars to accommodate permeable kerb.
- In situ concrete permeable kerb.
- Standard concrete mix.
- Strength – N20.

**Finish**

- Standard concrete finish.

**Construction**

- To engineers final specification.
- Tool joints at 3m typical centres (locate joints centrally between kerbs).
- Expansion joints at 9m typical centres (locate joints centrally between kerbs).

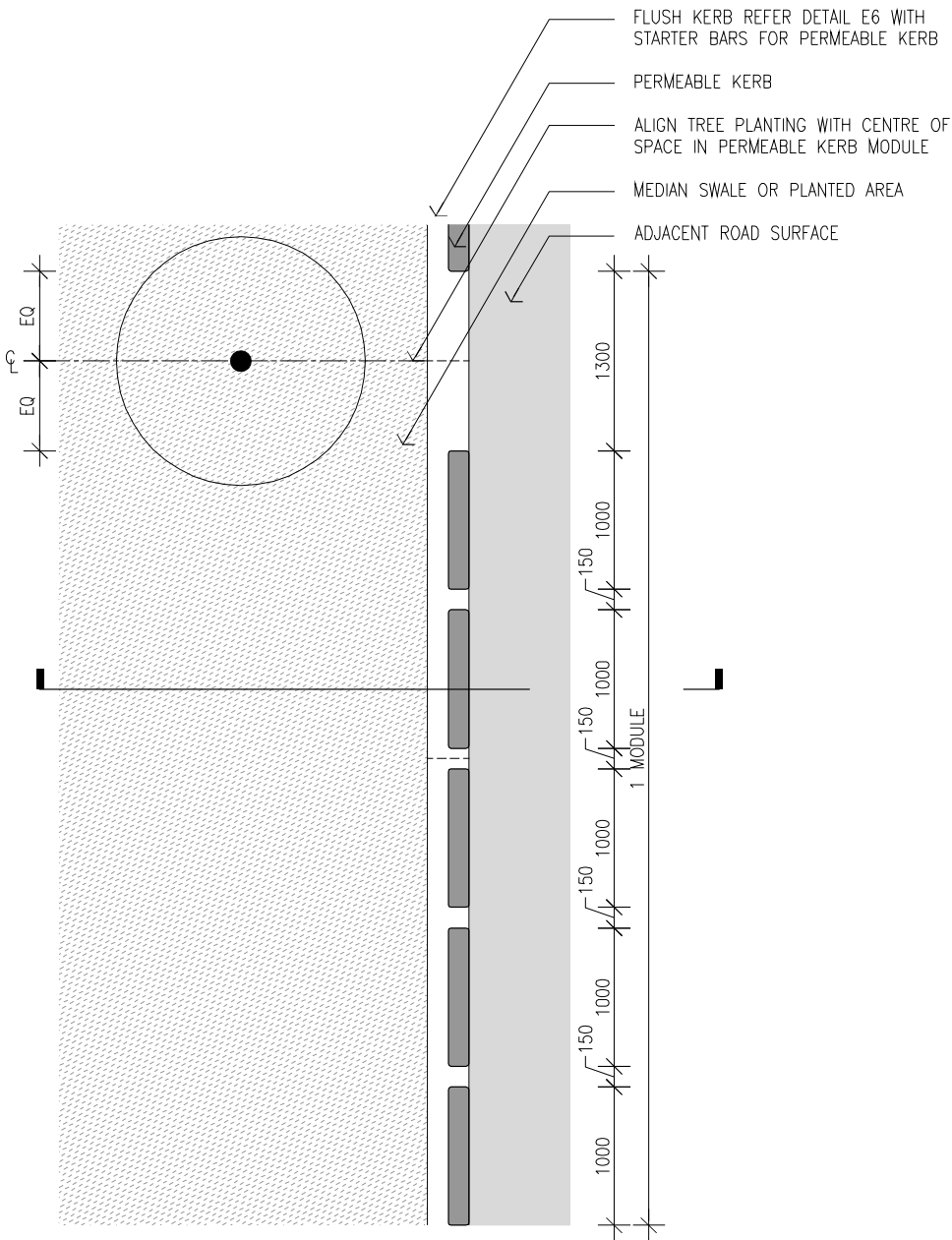

PLAN

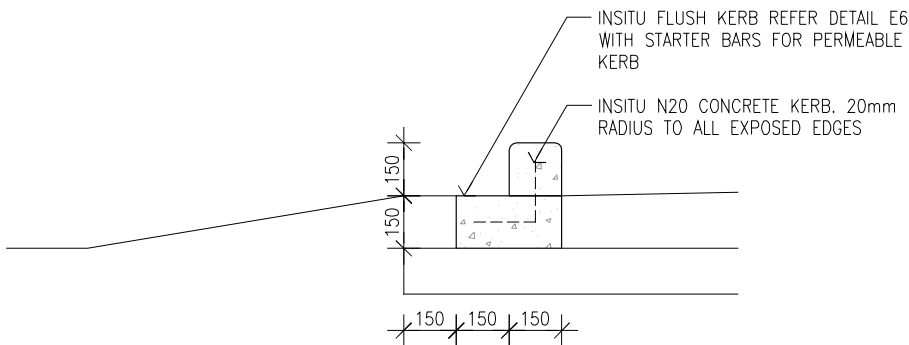

SECTION

S19A	S19B	S24	S33
------	------	-----	-----

<p><b>Principle</b></p>	<p>2008</p>	<p>DESIGN INTENT ONLY</p>
<p>For water sensitive urban design initiatives to be used as a permeable edge to swales and other planted areas to receive surface water.</p>	<p>Section 3.4 Engineering Elements</p>	<p>E7</p>

## Typical Vehicle Crossover



### Material

- Construct vehicle crossover in surrounding pavement material.
- Form kerb set down as shown.

### Construction

- To engineers final specification.
- Recycled base material to engineers final specification.

### Comment

- Driveways to comply with AS/NZS 2890.1: 2004 Parking Facilities Part 1 – Off Street Parking.

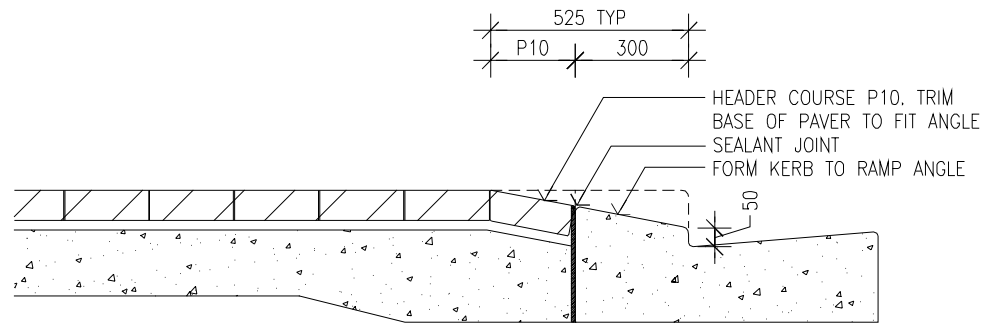
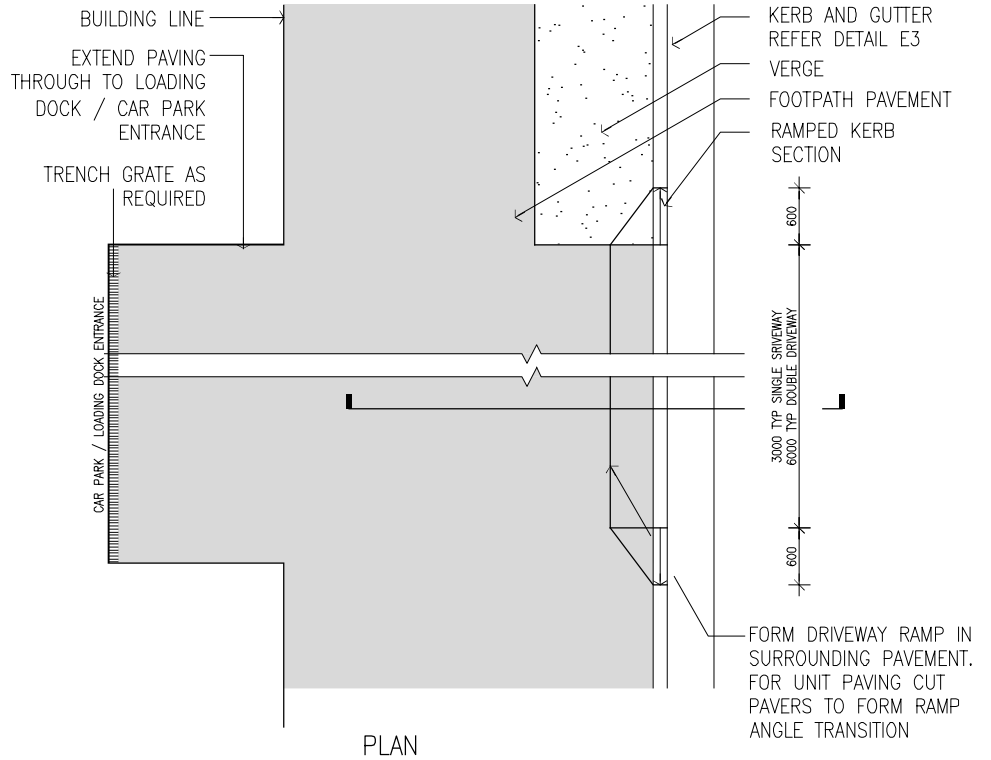

SECTION

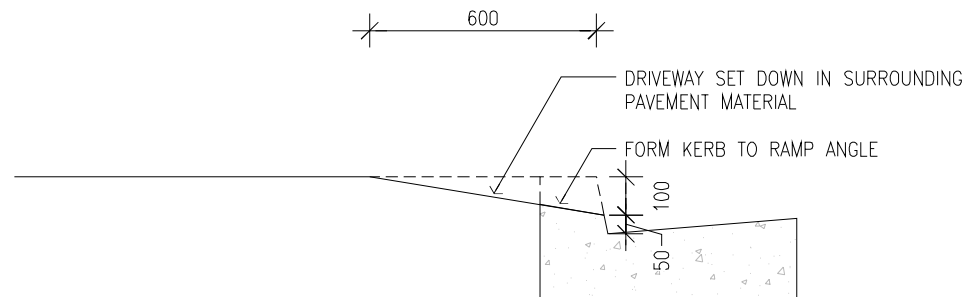

SECTION

AR

### Typical Trench Grate

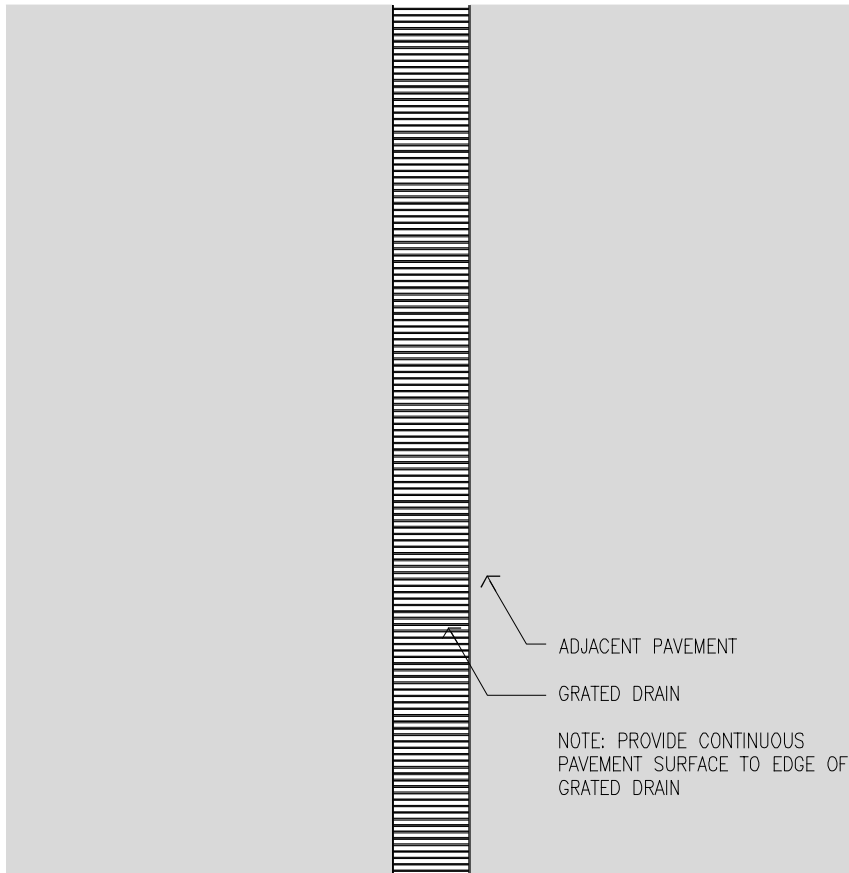

PLAN

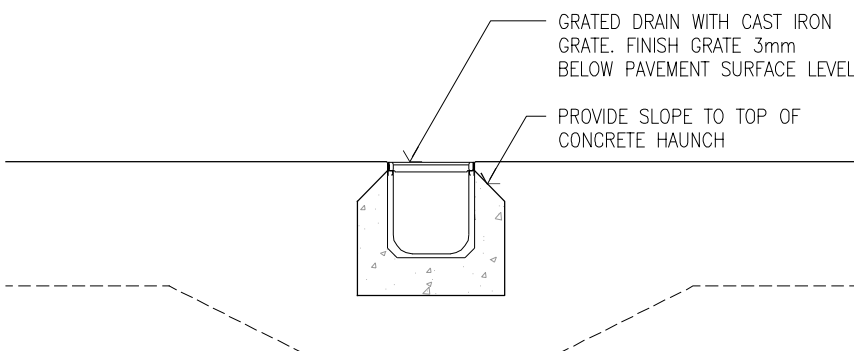

SECTION



**Material**

- Continuous cast iron trench grate as selected by landscape architect.

**Construction**

- Concrete surround to be set down below pavement surface.
- Openings to comply with AS 1428.
- Grate to be lockable.
- Concrete haunch to final design by engineer.
- Drainage requirements to final design by hydraulic engineer.

AR

**Principle**

Flush detail for integrated grated trench drain.

**2008**

**Section 3.4 Engineering Elements**

**DESIGN INTENT ONLY**

## Typical Sump Grate

### Material

- 600mm maximum cast iron sump grate and frame as selected by landscape architect.

### Finish

- Finish grate and frame flush with adjacent pavement.

### Construction

- Concrete surround to be set down below pavement surface.
- Openings to comply with AS 1428.
- Grate to be lockable.
- Concrete haunch to final design by engineer.
- Drainage requirements to final design by hydraulic engineer.
- Orientate grate square with adjacent elements.

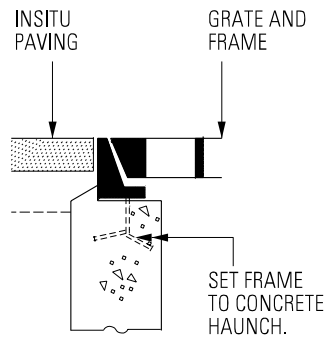

TYPICAL INSITU SECTION NTS

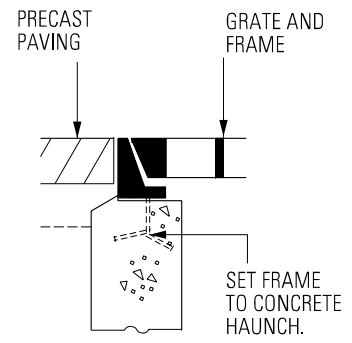

TYPICAL PRECAST SECTION NTS

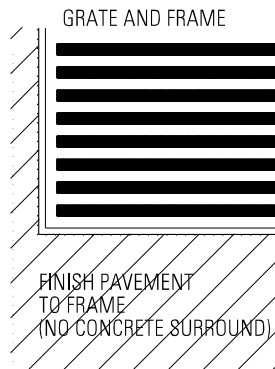

TYPICAL INSITU PLAN NTS

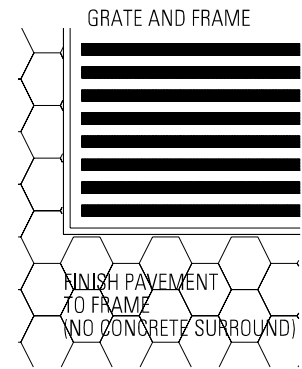

TYPICAL PRECAST PAVING PLAN NTS

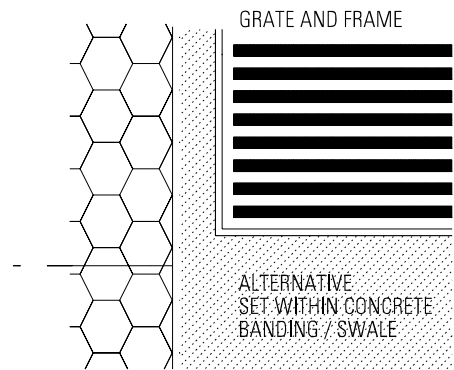

TYPICAL PRECAST PAVING PLAN NTS

AR

**Typical Service Cover General**

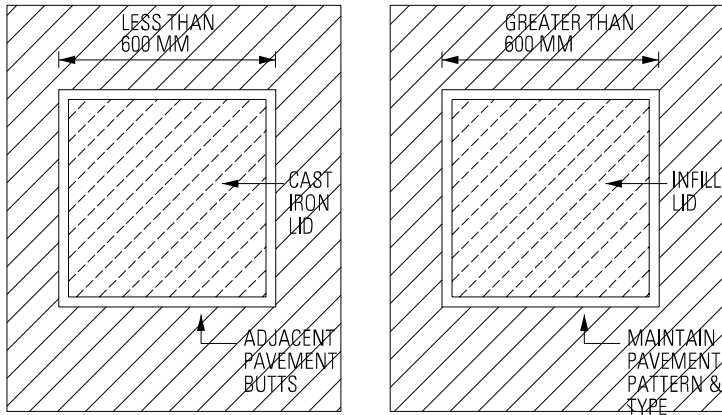

**CAST IRON**  
(LESS THAN 600MM)

**INFILLED**  
(GREATER THAN 600MM)

**TYPICAL PLAN NTS**

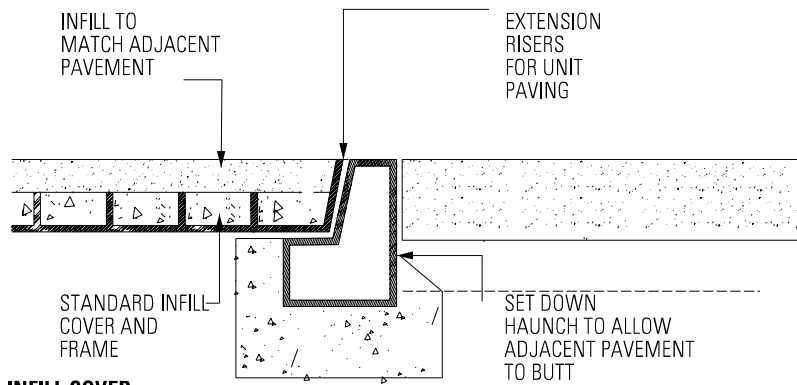

**INFILL COVER**

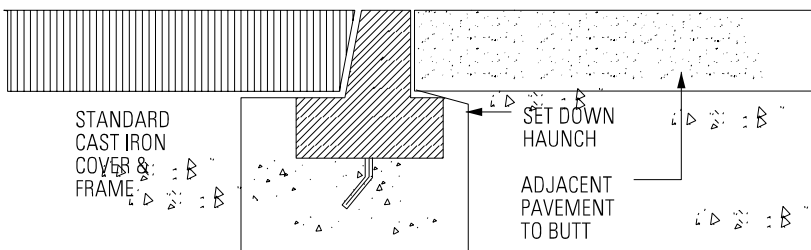

**CAST IRON COVER**

**TYPICAL SECTIONS NTS**

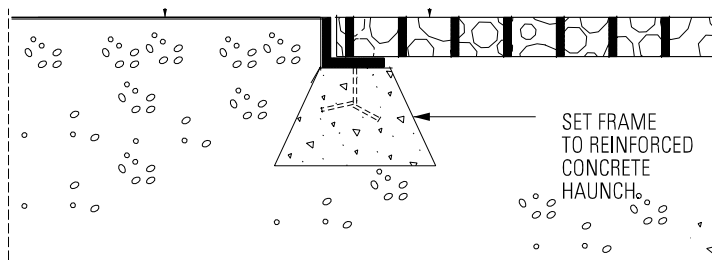

**TYPICAL SECTION 1:10**

**Materials**

- Service covers less than 600mm shape to be cast iron.
- Service covers greater than 600mm to be infilled with material to match the surrounding pavement.

**Finish**

- Concrete surround to be set down below pavement surface.
- Cover to be lockable.
- Concrete haunch to final design by engineer.
- Drainage requirements to final design by hydraulic engineer.
- Orientate cover square with adjacent elements.
- Metal pits only to be used.

**Principle**

To minimise impact of service covers and ensure integration with surrounding pavement.

**2008**

**Section 3.4 Engineering Elements**

**DESIGN INTENT ONLY**





# Street Tree Planting

Urban Elements Design Manual  
Section

# 3.5

ISBN 978-0-9805976-1-5

© All rights reserved. No part of this work will be reproduced, translated, modified, transmitted or stored in any form by any means without the prior permission of Sydney Olympic Park Authority.

## 3.5 Street Tree Planting

### Introduction

Appropriate trees are essential for beauty and amenity in the public domain. They provide shade, cooler temperatures and higher humidity during the hot summer months as well as wind mitigation, fauna habitat and ambience generally. Sydney Olympic Park has a strong legacy of landscape and street tree plantings established for the Games which is to be protected and enhanced. However, it has also become evident that some species originally planted for the Games are not sufficiently robust for the site and alternative species have been proposed to replace them. The parklands provide a natural setting to the town which can be enhanced by creating landscape links to the park and reinforcing indigenous plantings. The street trees have been selected to suit the strategy described below. The street tree plan shown on TP has been developed to meet the following objectives and incorporating extensive consultation with Landscape Architects, Arborists and in house staff with direct and enduring experience of the site.

### Objectives

Street trees at Sydney Olympic Park are to achieve the following objectives:

- retain and strengthen the existing plantings and landscape character;
- introduce colour and variety to the public domain through increased use of flowering trees and trees with autumn colour and coloured barks;
- prioritise species that are sufficiently hardy to flourish in the difficult soil and exposed, windy conditions;
- ensure the scale and form of the trees suits their location and the design of the street;
- choose suitable forms for the different footpath widths and building setback conditions in the streets;
- retain and enhance existing heritage plantings; and
- gradually replace species that have not flourished and are incapable of reaching appropriate height and form.

### Street Tree Strategy

- Extend the palette of indigenous rain forest trees on Olympic Boulevard to other civic streets to ensure the largest streets have the biggest and most formal tree plantings.
- Extend the Eucalyptus framework on major east west streets and the avenue streets to new east west and median streets.

- Extend the existing palette of endemic and indigenous trees in park edge streets to new park edge streets and in exposed sites.
- Use deciduous and semi deciduous trees in new north-south streets, preferably with colourful leaves or flowers for variety and to allow winter sun into these mostly residential streets.
- Use larger flowering, ornamental and rainforest trees in parks and pedestrian streets where there is sufficient space and easier growing conditions.
- Augment the urban forest with additional eucalypts with colourful bark and capacity to withstand the hot, dry and exposed conditions.

### Relevant Standards

Relevant Australian Standards include but are not limited to the following:

AS 3743 Potting mixes

AS 4419 Soils for landscaping and garden use

AS 4454 Composts, soil conditioners and mulches

AS 4373 Pruning of amenity trees

Other guidance documents include but are not limited to the following:

NATSPEC Guide: Specifying Trees – a guide to assessment of tree quality (Clark R. 2003)







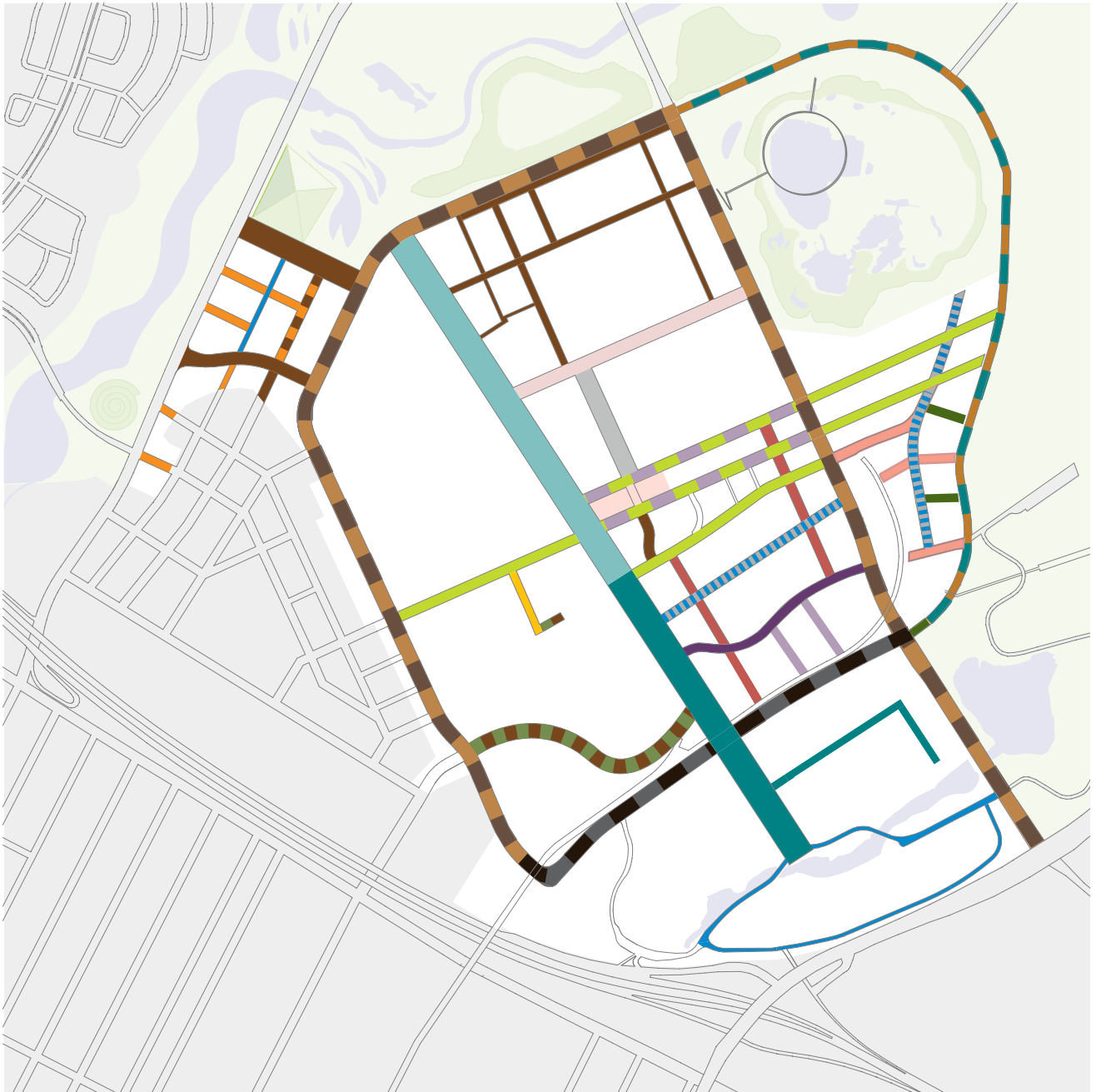











### Procurement

Procurement of urban elements must comply with the NSW Government's procurement policies.

**Street Tree Master Plan**



**Street Tree Key**

 <i>Ficus Hillii</i>	 <i>Corymbia maculata</i>	 <i>Eucalyptus pilularis</i> <i>Eucalyptus punctata</i> <i>Melaleuca quinquenervia</i> <i>Melaleuca decora</i> <i>Melaleuca styphelioides</i>	 <i>Pyrus calleryana</i> <i>Brachyciton x roseus</i>
 <i>Araucaria cunninghamiana</i>	 <i>Eucalyptus saligna</i>	 <i>Melaleuca leucadendra</i>	 <i>Flindersia australis</i>
 <i>Lophostemon confertus</i>	 <i>Fraxinus oxycarpa</i>	 <i>Eucalyptus sideroxylon</i> <i>Corymbia maculata</i> <i>Eucalyptus microcorys</i> <i>Eucalyptus punctata</i>	
 <i>Lophostemon confertus</i> <i>Pyrus calleryana</i>	 <i>Elaeocarpus eumundii</i>	 <i>Eucalyptus citriodora</i>	
 <i>Corymbia maculata</i> <i>Eucalyptus microcorys</i>	 <i>Acmena smithii</i> <i>Melaleuca leucadendra</i>		
 <i>Eucalyptus citriodora</i> <i>Eucalyptus sideroxylon</i>	 <i>Phoenix canariensis</i>		
	 <i>Celtis australis</i> <i>Platanus X acerifolia</i>		

## Street Tree Planting Species

Refer to table for street tree and understorey planting species listed by street type.

Refer also Section 2.1.2 Street Types for street tree master plan and arrangement of other urban elements.

### Tree Placement Notes:

- All new/replacement trees to be minimum 200L pot size to Natspec.
- Where new planting is required on existing streets, tree and understorey species and spacing are to match existing.
- Street tree and understorey planting is to comply with intersection sightline and other relevant traffic requirements.
- Service locations are to be checked and required clearances are subject to SOPA and relevant service authority requirements.
- No trees are to be planted along the length of a bus stop.
- Tree planting clearance to centre of a traffic signal pole is to be 10m.
- Transplanted trees subject to SOPA program.

Street	Street Type	Tree Species	Location	Nominal Spacing	Understorey Planting
<b>Civic Streets</b>					
1	Olympic Boulevard North	Ficus microcarpa 'Hilli'	Footpath	(Existing)	(Existing)
2	Olympic Boulevard South	Araucaria cunninghamiana	Verge	(Existing)	(Existing)
3	Dawn Fraser Avenue East	Lophostemon confertus	Parking	12m	
4	Dawn Fraser Avenue Station	Pyrus ussuriensis Lophostemon confertus	Parking Footpath	(Existing) (Existing)	(Existing) (Existing)
5	Dawn Fraser Avenue West	Lophostemon confertus	Footpath	10m	
6	Murray Rose Avenue East	Lophostemon confertus	Verge	(Existing)	(Existing)
7	Murray Rose Avenue Station	Pyrus ussuriensis Lophostemon confertus	Parking Footpath	(Existing) (Existing)	(Existing) (Existing)
<b>Perimeter Avenues</b>					
8	Australia Avenue	Eucalyptus microcorys Corymbia maculata	Verge Median	(Existing) (Existing)	(Existing) (Existing)
9	Kevin Coombes Avenue	Eucalyptus microcorys Corymbia maculata	Verge Median	(Existing) (Existing)	(Existing) (Existing)
10	Edwin Flack Avenue	Eucalyptus microcorys Corymbia maculata	Verge Median	(Existing) (Existing)	(Existing) (Existing)
11	Sarah Durack Avenue	Eucalyptus sideroxylon Eucalyptus citriodora Eucalyptus paniculata	Verge Verge Median	(Existing) (Existing) (Existing)	(Existing) (Existing) (Existing)
12	Holker Street	No planting	-	-	-
13	Pondage Link	Corymbia maculata	Verge	(Existing)	(Existing)
14	Old Hill Road	Corymbia maculata Corymbia maculata Corymbia maculata	Median Verge Median	(Existing) (Existing) (Existing)	(Existing) (Existing) (Existing)
<b>Town Streets</b>					
15	Herb Elliott Avenue	Lophostemon confertus	Footpath	(Existing)	(Existing)
16	Campus Walk	Pyrus ussuriensis var. ovoidea Pyrus ussuriensis var. ovoidea	Parking Footpath	12m 12m	
17	Showground Road	Phoenix canariensis	Footpath	(Existing)	(Existing)
18	Grand Parade	Platanus acerifolia	Footpath	(Existing)	(Existing)
<b>Local Streets</b>					
19	Median Street	Eucalyptus citriodora Melaleuca quinquinervia	Footpath Median	10m 10m	
20	Figtree Avenue	Eucalyptus saligna	Verge	(Existing)	(Existing)
21a	Verge Street	Fraxinus oxycarpa	Verge	10m	
21b	Verge Street	Flindersia australis	Verge	10m	
21c	Verge Street	Celtis australis	Verge	10m	
21d	Verge Street	Eucalyptus	Verge	(Existing)	(Existing)
22	Pedestrian Street	Acmena smithii	Verge	8m	
23	Shared Way	No planting	-	-	-
24	Car Parking Street	Lophostemon confertus	Parking	Every 6th bay	
25	Coach Parking Street	Celtis australis Celtis australis	Verge Footpath	8m 8m	
26a	Paved Street	Eucalyptus maculata	Footpath	(Existing)	(Existing)
26b	Paved Street	Flindersia australis	Footpath	(Existing)	(Existing)
27	Showground Street	Corymbia maculata	Footpath	(Existing)	(Existing)
<b>Park Edge Streets</b>					
28	Bennelong Street	Melaleuca quinquinervia Melaleuca decora Melaleuca stypheloides Eucalyptus pilularis Eucalyptus punctata	Verge Verge Verge Verge Verge	(Existing) (Existing) (Existing) (Existing) (Existing)	(Existing) (Existing) (Existing) (Existing) (Existing)
29	Majorie Jackson Parkway	Melaleuca quinquinervia Casuarina torulosa	Verge Verge	(Existing) (Existing)	(Existing) (Existing)
30	Shirley Strickland Avenue	Melaleuca leucadendra	Verge	(Existing)	(Existing)
31a	Park Edge Street Town Figtree	Flindersia australis	Verge	10m	
31b	Park Edge Street Town Figtree	Melaleuca leucadendra	Verge	10m	
32	Park Edge Street Haslam	Araucaria cunninghamiana	Park	15	
	Park Edge Street Haslam	Celtis australis	Footpath	10m	
33	Park Edge Street Golf	Melaleuca leucadendra Melaleuca leucadendra	Verge Parking	10m Every 6th bay	
34	Rod Laver Drive	Melaleuca leucadendra	Verge	-	
<b>Open Public Space</b>					
<b>New Parks</b>		Brachychiton acerifolius Brachychiton discolor Hymenosporum flavum Jacaranda mimosifolia Stenocarpus sinuatus Eucalyptus ficifolia gr. summer beauty Ficus rubiginosa Macadamia sp. Backhousia myrtifolia			
<b>Urban Forest</b>		Eucalyptus sideroxylon Corymbia maculata Eucalyptus microcorys Eucalyptus punctata			
<b>Station Square</b>		Pyrus calleryana Brachychiton x roseus		(Existing) (Existing)	(Existing) (Existing)

### Tree Planting in Verge

(Verge width < 1.5m wide.)

**Material/Finish**

- Tree planting.
- Massed groundcover planting.
- Spade edge to massed planting.

**Comments**

- Tree planting in centre of verge.
- Clear trunk height of 2m.
- Service clearances to be maintained.
- Tree planting to be carried out by a Landscape Contractors Association (LCA) affiliated contractor with demonstrated experience in landscape work, tree planting and tree establishment.
- Planting establishment period to commence at date of practical completion.
- Required establishment period of 2 years.
- All new/replacement trees to be minimum 200L pot size to Natspec.
- All soil volumes to be calculated by qualified arborist/registered Landscape Architect.

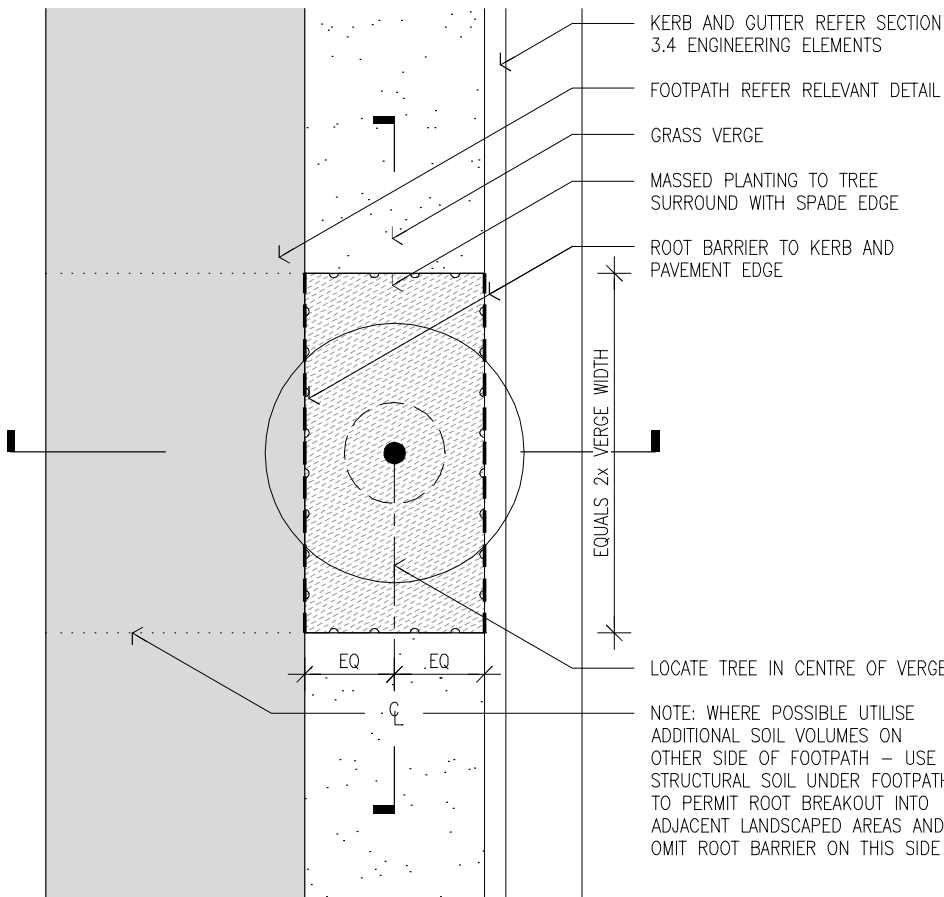

PLAN

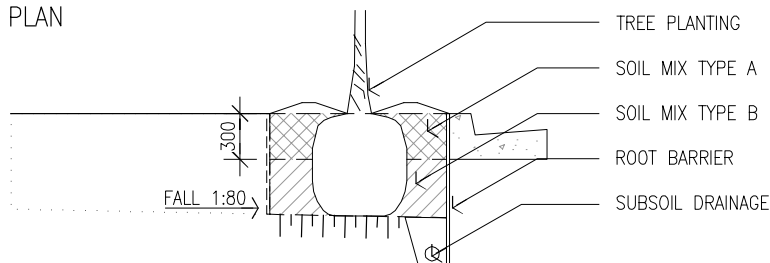

SECTION

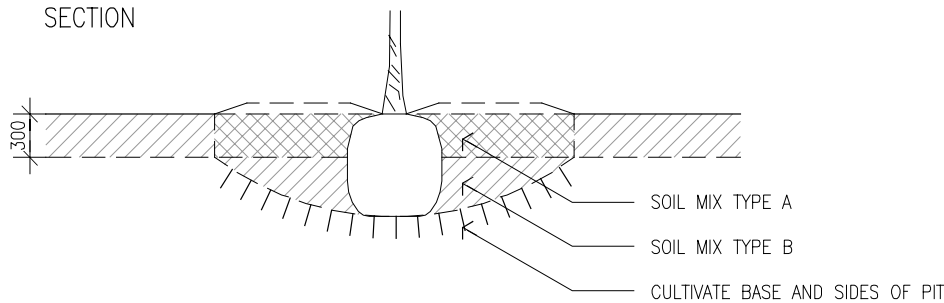

SECTION

**Principle**

Street tree planting in verge width less than 1.5m.

**2009**

**Section 3.5  
Street Tree Planting**

**DESIGN INTENT ONLY**

Section 3.5 Street Tree Planting

**Tree Planting in Verge**

(Verge width 1.5m or greater.)

**Material/Finish**

- Tree planting.
- Massed groundcover planting.
- Spade edge to massed planting.

**Comments**

- Tree planting in centre of verge.
- Maintain clear trunk height of 2m.
- Service clearances to be maintained.
- Tree planting to be carried out by a Landscape Contractors Association (LCA) affiliated contractor with demonstrated experience in landscape work, tree planting and tree establishment.
- Planting establishment period to commence at date of practical completion.
- Required establishment period to be 2 years.
- All new/replacement trees to be minimum 200L pot size to Natspec.
- All soil volumes to be calculated by qualified arborist/registered Landscape Architect.

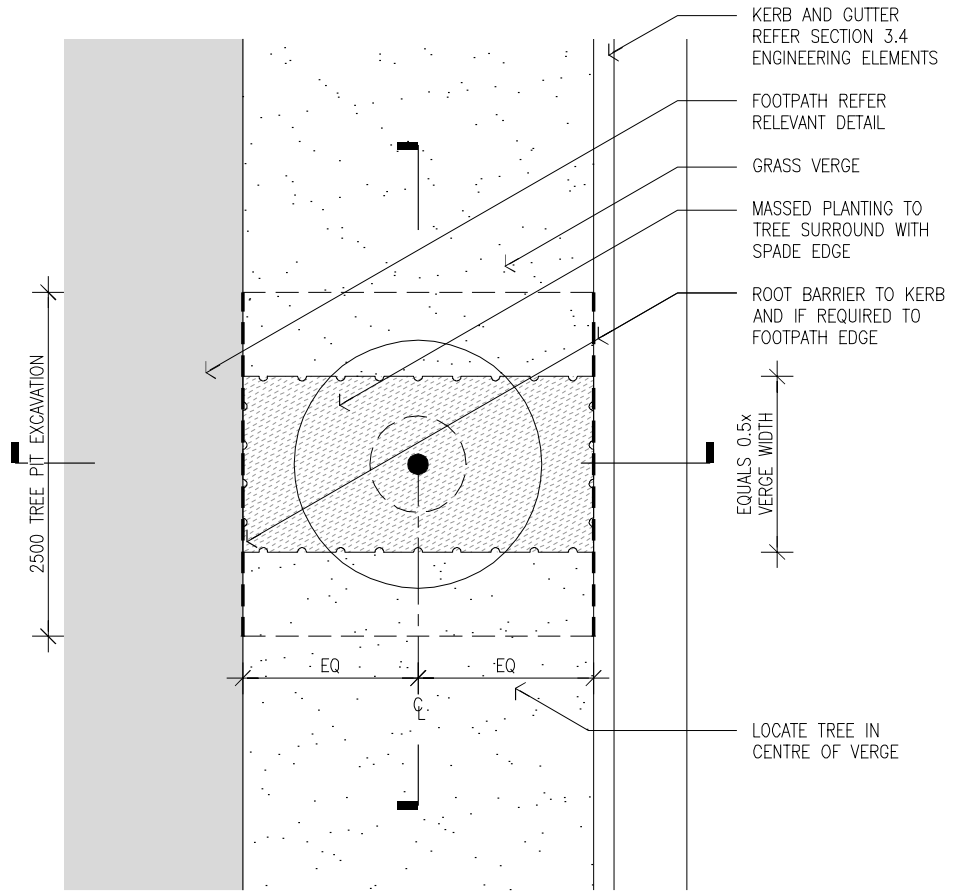

PLAN

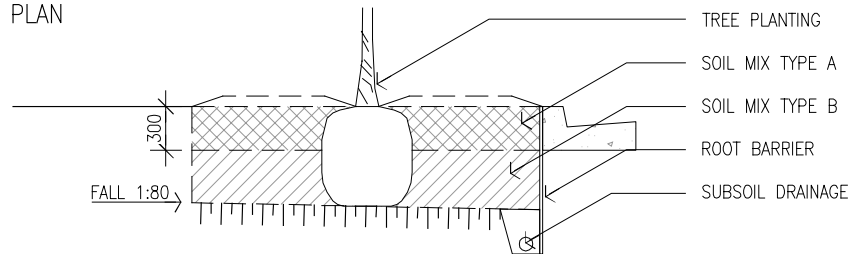

SECTION

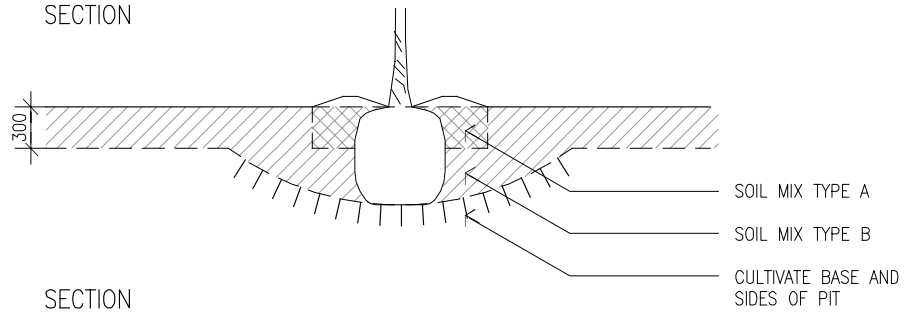

SECTION

S6 S20 S21A

S21B S22 S25 S31 S32 S33

## Street Tree Planting in Carriageway

### Materials/Finish

- Tree planting in kerb island with biofiltration tree pit materials.

### Comments

- Run-off water is directed via a GPT and biofiltration media to provide additional moisture to tree planting and improvement of water quality.
- Tree spacing as nominated in T1.
- Maintain clear trunk height of 2m.
- Service clearances to be maintained.
- Tree planting to be carried out by a Landscape Contractors Association (LCA) affiliated contractor with demonstrated experience in landscape work, tree planting and tree establishment.
- Planting establishment period to commence at date of practical completion.
- Required establishment period to be 2 years.
- All new/replacement trees to be minimum 200L pot size to Natspec.
- All soil volumes to be calculated by qualified arborist/registered Landscape Architect.

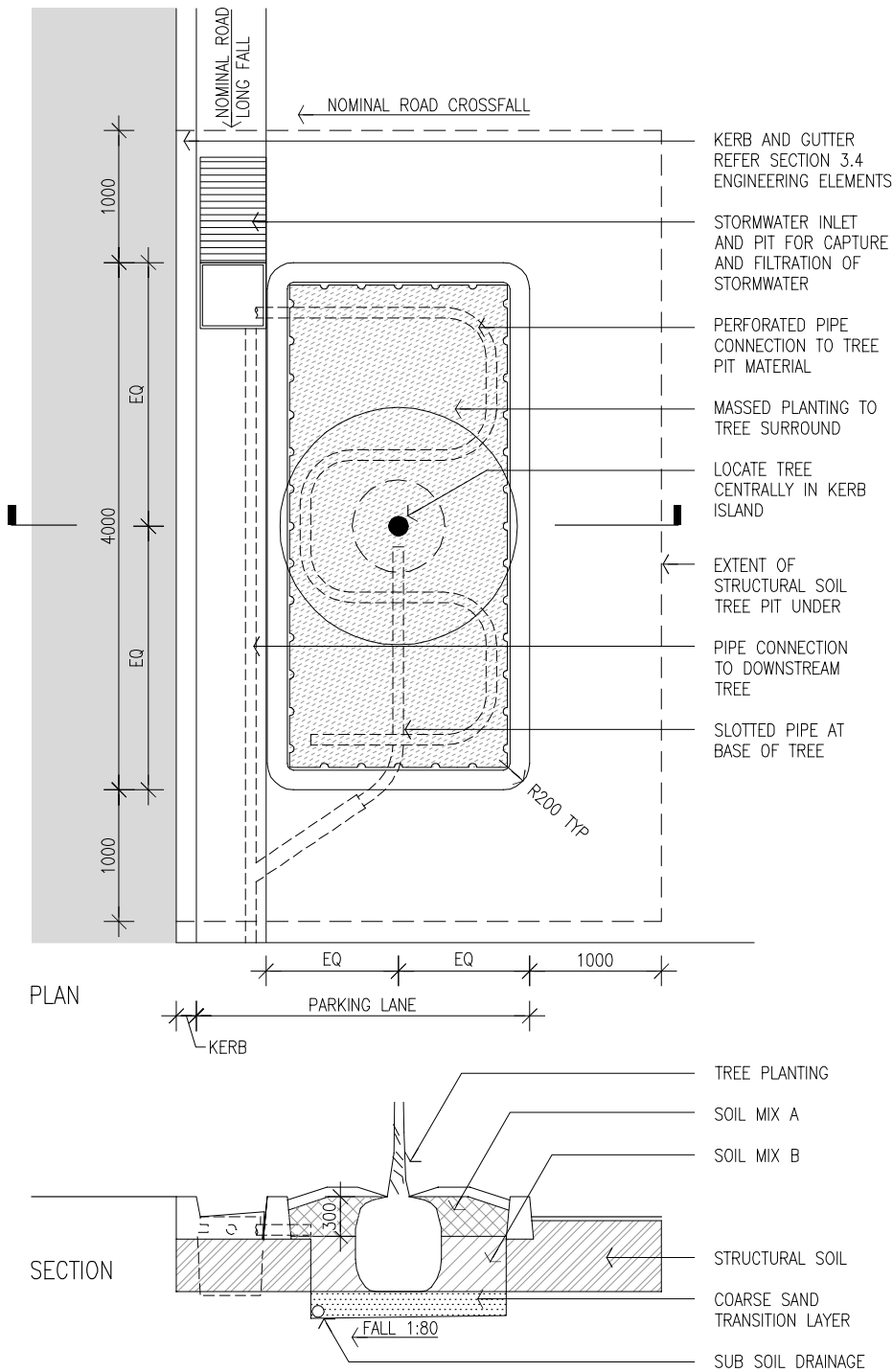

### Principle

Street tree planting in street carriageway to incorporate water sensitive urban design initiatives.

### 2009

Section 3.5  
Street Tree Planting

### DESIGN INTENT ONLY

## Street Tree Planting in Paved Footpath



### Materials

- Tree planting.
- Tree grate (refer detail SF26).
- Permeable pavement band adjacent to tree grate.

### Comment

- Maintain clear trunk height of 2m.
- Service clearances to be maintained.
- Tree planting to be carried out by a Landscape Contractors Association (LCA) affiliated contractor with demonstrated experience in landscape work, tree planting and tree establishment.
- Planting establishment period to commence at date of practical completion.
- Required establishment period to be 2 years.
- All delivery, handling and placement of structural to be under supervision of qualified Arborist.
- All new/replacement trees to be minimum 200L pot size to Natspec.
- All soil volumes to be calculated by qualified arborist/registered Landscape Architect.

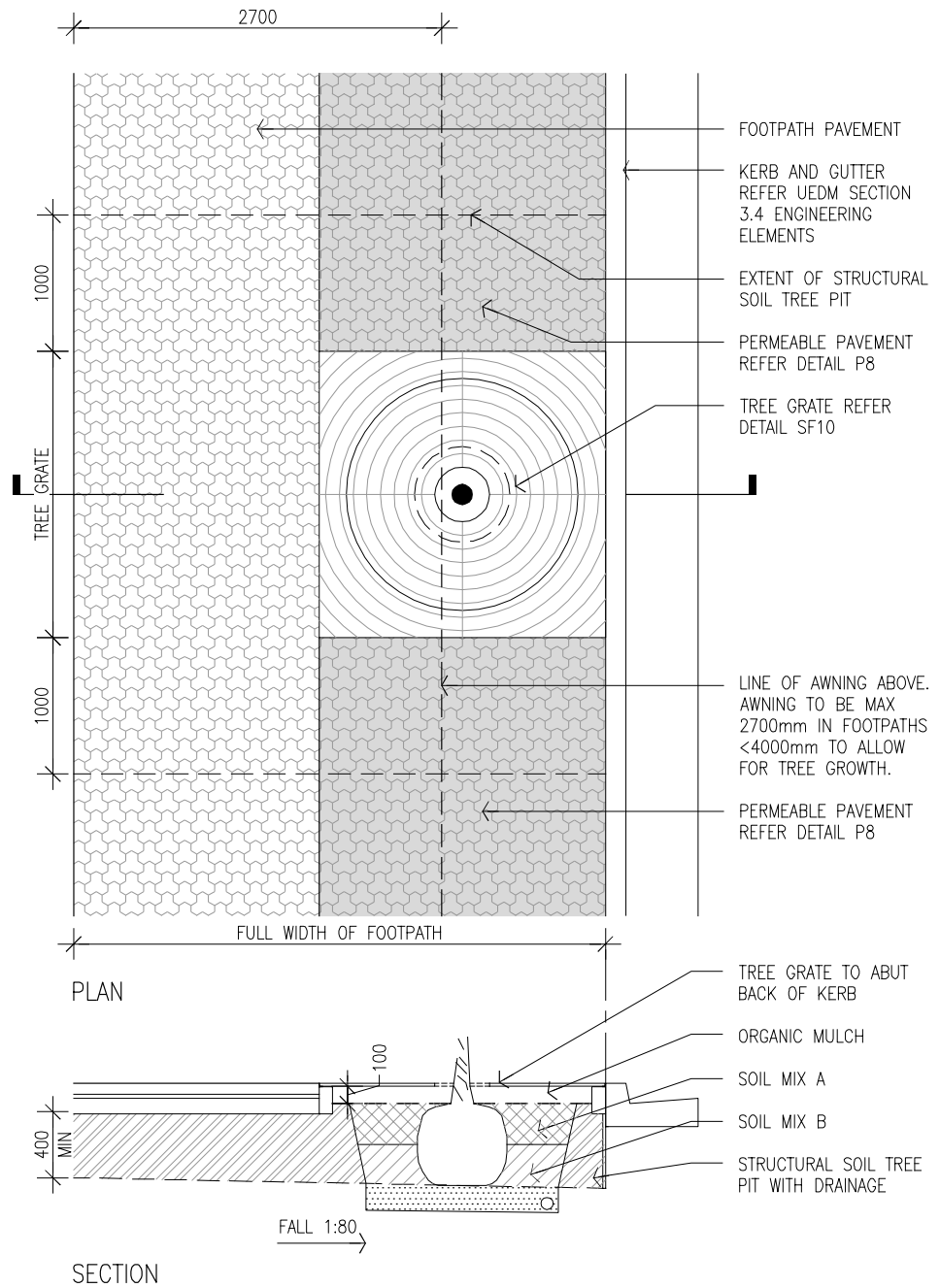

S4

S5

S7

S15

S16A

S16B

S25



**Structural Soil**

**1.0 GENERAL**

**1.1 GENERAL DESCRIPTION**

A structural soil mix creates a large particle matrix composed of aggregates used in sufficient volume or proportions so that they define the packing limitation of the soil and determine the resulting pore space.

Ideally, aggregates should be angular and the larger aggregates must be touching; the load is then transferred mainly for large aggregate to large aggregate. With intermediate particle sizes missing from the mix, resulting pores between the larger aggregates are then filled with a finer filler soil that will be relatively free from compactive stress. It is this correctly formulated filler soil that provides the moisture holding nutrient buffer capacity. Together with high aeration properties provided by the large voids, suitable space and conditions are provided for root growth. The size of voids is dependent on the base material aggregate size.

**1.2 INTERPRETATION**

**Definitions**

Structural soil mixture: Aggregate, filler soil and compost or other additives, thoroughly pre-mixed before placing.

**2.0 SCOPE OF WORK**

All works will be executed as part of the Works package.

Tree planting will include but is not limited to:

- Excavation of subgrade for continuous tree pit/trenches.
- Supply and installation of structural soil mix.
- Supply and installation of subsoil drainage.
- Installation of nominated trees.
- Establishment and maintenance following completion of planting.

This specification describes the appropriate techniques to be used to install trees in tree pits incorporating structural soil. There may be allowance for some variation in the techniques to be used by the contractor, however any change to techniques from those described here must be submitted in a Work Methods Statement for approval by the SOPA Site Representative SOPA Site Representative prior to work being carried out.

**2.1 STANDARDS**

All work shall be in accordance with the relevant standards. The following standards are referred to in this section:

AS4419 Soils for landscaping and garden use – 1998

AS4454 Composts, soil conditioners and mulches - 1997

Principle	2009	DESIGN INTENT ONLY
	Section 3.5 Street Tree Planting	<b>T6</b>

**Structural Soil****3.0 QUALITY****3.1 EXPERIENCE**

All tree planting works will be carried out by a Landscape Contractors Association (LCA) affiliated contractor who has demonstrated experience with and knowledge of the use of structural soil, tree planting and tree establishment. Allocate or engage the services of personnel experienced in each of the specialised trades as nominated at the time of the tender, including personnel with appropriate licenses for the operation of machinery and the use of chemical sprays.

All tree planting, tree establishment and maintenance work will be carried out by qualified horticulturists with a minimum of 3 years experience in the horticultural/landscape industry. It is a requirement that the foreman will have the minimum qualification of a NSW TAFE Course Certificate in Urban Horticulture, or its recognised equivalent, with a minimum 5 years demonstrable experience in similar landscape projects.

All tree surgery work will be carried out by an approved, qualified Arborist; defined as having as a minimum, the NSW TAFE Course Certificate in Urban Horticulture, including a pass in the elective Tree Care and Maintenance, or NSW TAFE Tree Surgery Certificate or its recognised equivalent. The Arborist shall also have a minimum of five years experience in practical arboriculture including demonstrated experience in tree diagnosis and tree surgery.

**3.2 INSPECTION****Hold points**

Provide not less than 48 hours notice so that the SOPA Site Representative can make the following inspections:

- Tree pits/trenches excavated and prepared for backfilling with structural soil.
- Delivery of structural soil prior to unloading.
- Structural soil mixture spread and compacted within tree pits/trenches.
- Completion of installation of subsoil drainage and connection to pits to ensure adequate drainage.

Work shall not proceed until approved by the SOPA Site Representative.

**Witness points**

Provide not less than 48 hours notice so that the SOPA Site Representative can make the following inspections:

- Set out completed.
- Tree trench excavations set out prior to excavation.
- Temporary protective sheeting to stockpiled structural soil.
- Temporary protective sheeting installed to structural soil surface
- Soil testing prior to installation of aggregate base course and pavers
- Completion of all soil remediation works prior to installation of aggregate base course and pavers (where applicable).

**3.3 TESTS****Soil Testing**

Separate soil tests will be carried out at the following stages:

AR

**Structural Soil**

- Initial testing of structural soil mix and filler soil prior to installation.
- Testing following installation but prior to installing aggregate base course and permeable pavers.

Test results provided with structural soil mix samples must be current for the material supplied. Test results from old batches will not be accepted.

Provide chemical tests from the nominated soil laboratory confirming that the structural soil mix meets the required specification. Take samples in the manner indicated by the testing authority, including carefully labelling of bags and providing copies of the soil specification.

The purpose of tests is to ensure that the structural soils meet the required specification and has not been contaminated by concrete washings or other waste material that may adversely affect the growth of the trees.

The contractor shall incorporate all necessary amendments and undertake all remediation or amelioration recommendations arising from the soil laboratory’s results. All remediation or amelioration of structural soil chemistry arising from the contractors non compliance with the tree and rootzone protection specifications will be at the contractor’s own cost. The nominated soil laboratory is:

**Sydney Environmental and Soil Laboratory.**

**16 Chilvers Road, Thornleigh NSW 2120**

**Telephone: (02) 9980-6554**

**Sampling**

As recommended in AS 4419 (Int) 1996 Appendix A and as recommended by the soil testing authority.

**Type of test required on structural soil filler mix**

"Basic Soil Test" as provided by Sydney Soil and Environmental Laboratory or approved equal. Test results should include pH in water, pH in CaCl<sub>2</sub>, electrical conductivity – salinity, exchangeable Na, K, Ca, Mg & Al and available PO<sub>4</sub>

**Number of tests and timing**

Collect separate representative soil filler samples, comprising at least 6 composites samples, obtained from the top 300mm of the tree pit/trenches. Collect samples of structural soil mix before installation of aggregate base course and pavers. All costs of testing including transport to the laboratory, to be borne by the contractor.

**Locations**

Collect composite samples at random from separate representative tree pits/trenches and or where there is evidence of contamination, as directed by the SOPA Site Representative. Ensure that there is no mixing of composites from separate tree pits/trenches. Ensure that separate soil samples are accurately labelled, indicating which tree pit/trench they were collected from. Collect and test only structural soil samples.

**Test Results**

Provide copies of all soil analysis tests a programme of any remediation works base on test results to the SOPA Site Representative. Remediation of the in situ structural soil will be at the contractor’s cost.

**3.4 SAMPLES**

General: Submit representative samples of each material, packed to prevent contamination and labelled to indicate source and content.

AR

Principle	2009	DESIGN INTENT ONLY
	Section 3.5 Street Tree Planting	T6

## Structural Soil

### Samples Schedule

Item	Quantity
Structural Soil Mix	As required by Soil Testing
Imported Soil Mix	500g
Soil Amendments	500g of each amendment type

## 4.0 MATERIALS

### 4.1 MACHINERY AND EQUIPMENT

Ensure all machinery and equipment brought on to site has been thoroughly cleaned off site using high pressure water cleaning equipment and detergent prior to the commencement of all works to ensure that the fungal diseases or inoculum of *Phytophthora cinnamomi* are not brought on to the site.

### 4.2 WATER

Connection points for water are to be advised by the SOPA Site Representative.

The Contractor shall provide flexible hoses etc as required for the works from water points in locations.

### 4.3 IMPORTED SOIL MIX

Where imported soil mix is required for backfilling to planted tree rootballs, imported soil mix will be a 60:40 mix comprising 60% 2mm washed sand and 40% screened premium loam soil.

### 4.4 STRUCTURAL SOIL MIX

The structural soil growing medium shall be a thoroughly combined mix of 4 parts aggregate to 1 part filler soil as described below.

Structural soil components should be equivalent to: 80% by volume 40mm basalt aggregate or Nepean River gravel, 10% by volume screened sandy loam, 10% by volume screened dolerite and additives. Aggregate/gravel to be clean and free from clay clods and other matter.

#### Required Filler Soil Properties

Filler soil shall be thoroughly combined mix of 1 part Menangle sandy loam to 1 part screened dolerite with the following properties:

Organic matter	<1% by weight
Optimum Moisture Content	12.5%
Maximum dry density (t/m <sup>3</sup> )	1.95 STD
CBR	20-30%
Total Porosity	42%
pH in water	5.5-6.5
pH in CaCl <sub>2</sub>	5.5-6.5

AR

## Structural Soil

Electrical conductivity	1.0 – 1.8 mS/cm
Chlorides	30-85mg/kg
Sodium	<5% ECEC
Potassium	5-15% ECEC
Calcium	60-75% ECEC
Magnesium	5-25% ECEC
Calcium / Magnesium ratio	3:6
Phosphorous	10-50mg/kg
Ammonium	<100mg/kg
Nitrate	<100mg/kg
Sulphate	40-100mg/kg

**Filler mix shall be free of stones and other debris greater than 15mm.**

### Additives

The following additives are to be thoroughly mixed with above filler soil prior to blending with crushed aggregate. Additives will be tested for compliance prior to blending with the crushed aggregate:

Additives	Rate
Magrilime	600g/m <sup>3</sup> (to bring pH to 5.5-6.5)
Trace element mix	300g/m <sup>3</sup>
Potassium nitrate	500g/m <sup>3</sup>
Ammonium Nitrate (Nitram)	500g/m <sup>3</sup>
Superphosphate	500g/m <sup>3</sup>
Iron Sulphate	1500g/m <sup>3</sup>
8-9 month control release fertiliser	2000g/m <sup>3</sup>
Gypsum	500g/m <sup>3</sup>
Magnesium Sulphate	400g/m <sup>3</sup>

### Aggregate

Aggregate shall be 40mm crushed Nepean River gravel or crushed basalt. Gravel shall be clean and free from clay or other matter. The aggregate shall be of the following particle size distribution:

A.S Sieve (mm)	Percent Passing
53.0	100
37.5	90-100
26.5	0-75
19.0	<15

AR

## Structural Soil

13.2	<2
9.5	<2
6.7	<2
4.75	<2

**Note: Recycled or railway ballast aggregate (or similar) will not be accepted. Removal of such material for the site will be at the contractor's expense.**

### Moisture Levels

The structural soil mix shall be maintained at a moisture level that ensures that the filler component adheres to the aggregate at all stages of transport, handling on site, installation and compaction.

### Transportation

Structural soil mix shall be delivered to site pre-blended in a covered/tarped vehicle. The soil mix shall be transported in a moist condition to prevent segregation of components. Material delivered to site exhibiting excessive separation of filler will be rejected. Any off-loaded material that does not comply with moisture requirements shall be reloaded and taken off site at the contractor's expense.

### Structural soil delivery

All soil mixes installed on site shall be in accordance with the approved sample. Random sampling and testing of soil mixes will be undertaken by the SOPA Site Representative during the progress of the works. All soil mixes that do not comply with the specification will be rejected and must be removed from site at the contractor's cost.

Each load of soil mix delivered to site must be accompanied by the supplier's delivery docket which identifies the load, batch and confirms the volume and weight and certifies that the soil mix complies with the specification. All dockets must be available for presentation to the SOPA Site Representative prior unloading of the soil mix. All deliveries without the above documentation may not be accepted onto the site. Acceptance of a soil mix delivery will be at the sole discretion of the SOPA Site Representative.

## 4.5 STORAGE

### Storage

Stockpiled structural soil shall be covered if it is to be stored for any longer than 8 hours or prior to any rain events. If not covered, the aggregate/filler mix shall be re-mixed before use as described below ensuring uniform distribution of filler within the stone.

### Re-Mixing Materials

Re-mix structural soil as directed by the SOPA Site Representative where separation of materials occurs. Structural soil shall be thoroughly re-mixed on a flat sealed surface free of other soil and debris. Mix the layered material until the soil is uniformly distributed within the stone, adding sufficient water to the mix to ensure that soil filler does not fall away from aggregates. Generally, correct moisture content is apparent when the filler material is "tacky" and sticks as a thin layer across the entire surface of individual aggregates. Filler soil that is too dry or too wet will not adhere to aggregates and will be rejected.

**Structural Soil**

**5.0 TREE PIT PREPARATION**

**5.1 EXCAVATION OF TREE PITS/TRENCHES**

**Requirement**

Excavate tree pits and linked continuous tree trenches to the required depths. Remove all excavated materials from site. Do not disturb services, excavate by hand around services as required.

**Excavation Depths**

Tree pits: Depth of excavation for tree pits shall be as indicated on the details.

Allow additional excavation as required to achieve specified falls to subsoil drainage lines.

**5.2 SUBGRADE PREPARATION**

**Cultivation**

Cultivate or rip subgrade at base and sides of tree pits and continuous trenches to a depth of 100mm. Cultivate manually within 300 mm of existing structures or services. Do not disturb services, excavate by hand around services as required. During cultivation, thoroughly mix in any materials required to be incorporated into the subsoil. Remove stones greater than 50mm and any debris, rubbish or deleterious material brought to the surface during cultivation. Trim the base of tree pits and trenches to the required design levels, falls and shapes after cultivation.

**Additives**

Apply Gypsum during cultivation incorporate into the upper 100 mm layer of the subgrade of tree pits and trenches as scheduled.

**Soil Additives Schedule**

Location	Additive Type	Rate
Upper 100mm of subgrade	Gypsum	0.2kg/sq.m

**5.3 PLACING SOIL MIX**

**Contamination**

Where diesel oil, cement or other phytotoxic materials have been spilt on the subsoil or soil mix, excavate the contaminated material, dispose off site and replace with new site subsoil and/or soil mix as directed to restore design levels.

**Placing structural soil mix**

General: Spread the structural soil on the prepared subsoil following installation of subsoil drainage lines. Grade evenly and compact, making the necessary allowances to permit compliance with the required finished levels and contours.

Backfill and compact structural soil mix in all nominated tree pits areas in layers 150mm maximum thickness. Repeat backfilling and compaction in layers until desired levels are achieved. Avoid differential subsidence and excess compaction.

The structural soil is to remain in a thoroughly blended composition and be kept moist during backfilling and compaction to prevent segregation of soil mix components. **Watering in the structural soil during installation is not permitted.** If any segregation of the aggregate and filler soil occurs, excavate the segregated material and re-mix to an even and uniform consistency prior to continuing backfilling and compaction.

AR

## Structural Soil

Confirm that the excavated tree pit is free draining. If not, notify SOPA Site Representative and seek instructions before backfilling.

### Compaction

Thoroughly and evenly consolidate each layer using approved mechanical equipment to achieve a uniform density of not less than 95% maximum dry density as determined by AS1289.5.1.1 at design levels

### Existing Services

Do not disturb services during backfilling and compaction.

### Structural soil depths

Spread and compact structural soil to a finished minimum depth as shown on the Detail.

## 5.4 TREE PLANTING LOCATIONS

### Installation

Tree planting locations should be left uncompacted to allow ease of planting. Three accepted methods of locating the tree planting area include:

- Use of a preformed steel or timber formwork constructed to a size large enough to permit installation of the nominated tree rootball dimensions.
- Use of sandbags placed in a setout large enough to permit installation of the nominated tree rootball dimensions.
- Excavation of compacted structural soil in the nominated tree planting locations. Excavation of compacted material should avoid undue disturbance. Re-compact surrounding structural soil mix following tree installation to ensure no less than 95% maximum dry density.

## 5.5 SURPLUS

General: Dispose off site.





# Signage

Urban Elements Design Manual  
Section

# 3.6

ISBN 978-0-9805976-1-5

© All rights reserved. No part of this work will be reproduced, translated, modified, transmitted or stored in any form by any means without the prior permission of Sydney Olympic Park Authority.

# Permanent Signage Design Strategy

## Introduction and General Objectives

### Signage objectives for Sydney Olympic Park

- to provide clear public information
- to unify the site through signage
- to extend the urban planning intentions
- to convey a dynamic spirit and identity for a major recreational venue
- to recognise two conditions: major event and 'normal' mode.

### There are two basic signage site conditions

- the overall Sydney Olympic Park site
- the Boulevard and Plaza.

### Signage reinforces the Boulevard as the defining urban element.

### Key signage design issues

- urban legibility
- sense of place and place making
- an identity for Sydney Olympic Park
- integrating a large site.

The signage extends beyond the site, to signal Sydney Olympic Park at airports, transport interchanges and along approach roads.

## Sign Strategy

Sydney Olympic Park requires two sign systems

1. permanent signs
2. a temporary overlay of promotional and events signs.

## Permanent sign

### Six sign types

1. Identification – naming places and destinations.
2. Circulation – directions to and from places and destinations.

3. Services – naming of toilets and public facilities.
4. Regulatory – authorities' regulatory, prohibitive and safety information, including fire, building and statutory.
5. Information – general information for operations.
6. Promotion – advertising information for promotion of special events and facilities.

These six sign types all occur right across the site.

In each type a hierarchy of messages conveys different levels of information: primary and secondary.

A modular sign system accommodates the repetition of signs and hierarchy of messages.

Public way-finding information is clearly differentiated from promotional or regulatory information.

Colour coding differentiates between circulation, service information and warnings.

### Number of signs

- as a general rule, signs should be kept to a minimum and messages kept simple and concise. Too much information is confusing.
- information of the same category should be grouped together to reduce the impact of too many signs.

### Pylon sign structures

- large scale is appropriate for dense crowds
- define boulevard as main circulation and information point
- ordering devices in an extensive landscape
- provide dramatic signal of entry at gateways
- made from recycled steel

The pylon form of sign structures transforms the negative, derided electricity pylons into celebratory icons and major identifiers of Sydney Olympic Park.

### Structures and materials

- robust
- low-maintenance: concrete and metal
- environmentally sound
- Australian-sourced where possible
- to complement architectural design details

### Electronic signs

- public information and imagery on the Boulevard, incorporating text and video
- transit information at venue exit points
- updated car parking information along access routes
- when informative messages, such as those listed above, are not required, it is preferable to display decorative or welcoming messages when possible

### Changeability

#### Signage accommodates

- Olympic mode
- permanent mode
- expansion of sign system with further site development

The modular signage system is flexible for easy updating.

#### Large mapping

- logical
- simple
- easily comprehended

#### Placement of circulation signs

- on logical circulation routes
- at decision points
- at arrival at destination
- at appropriate heights for pedestrians and vehicles
- with clear, unimpeded sight-lines

Placement of signs can increase the legibility of the signage system. Consistency of proportion, orientation and the spatial arrangement of signs in relation to their contexts affects legibility and recognition.

#### Special signage

- tactile mapping, tactile service signs and text for visually impaired
- pictograms for functionally illiterate and non-English speaking

#### Lighting

Signs to be internally illuminated where possible for impact and clarity. Major freestanding sign structures should be face-lit in order to be recognised as markers.

### Typeface

#### The typeface used is a sans serif for

- clarity and legibility
- contemporary
- international image

Specially customised 'Olympic 2000' typeface is used for signage and is an opportunity to signal

- a major occasion in Australia's history
- the new millennium
- Sydney Olympic Park as a special place

### Pictograms

- international standards to overcome language barriers
- spirited pictograms to express individuality of Sydney Olympic Park

Pictograms are used as both a reinforcement of word messages and an independent order of informational elements in their own right. In most instances, written notices convey information more efficiently than pictograms or symbols.

#### Pictograms are used for

- signalling public facilities: toilets, trains, buses, taxis, disabled
- announcing regulations: no smoking, no entry
- signalling directions

#### Prototypes

A selection of signs were prototyped to test

- legibility
- colours
- fixings
- finishes
- performance

This process established a control model which will ensure consistency when using different manufacturers.

### Procurement

Procurement of urban elements must comply with the NSW Government's procurement policies.

Identification Signs

Primary Blade Signs

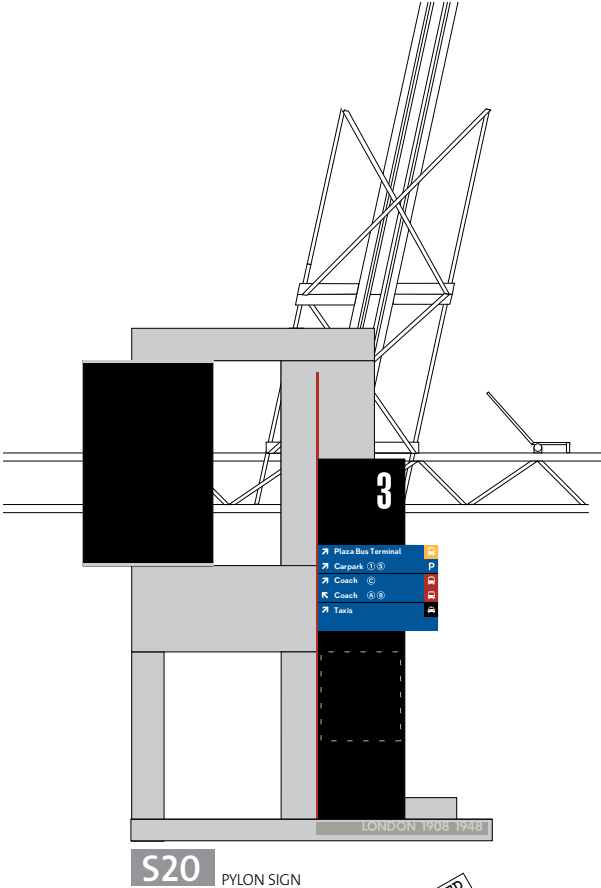

**S20** PYLON SIGN

Primary Blade Signs

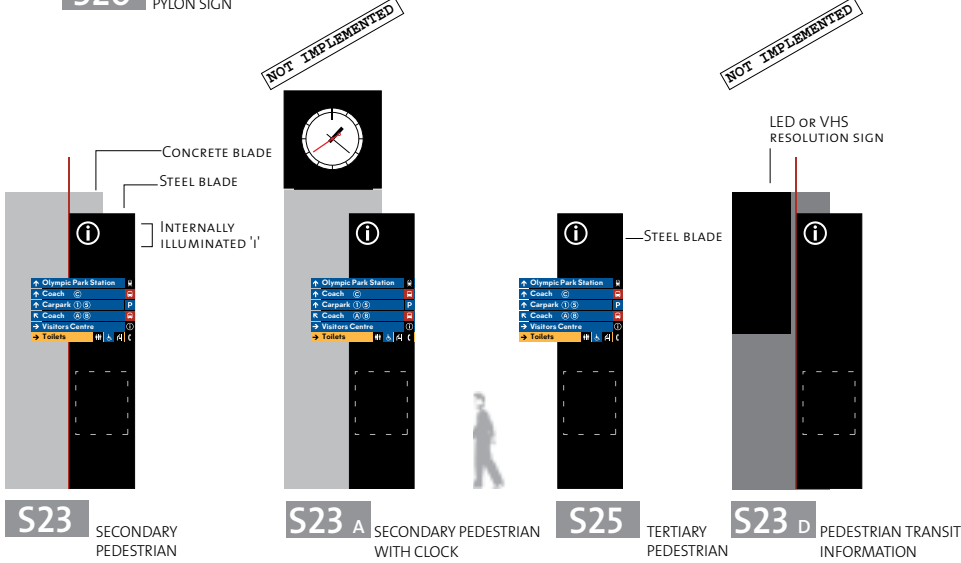

**S23** SECONDARY PEDESTRIAN

**S23 A** SECONDARY PEDESTRIAN WITH CLOCK

**S25** TERTIARY PEDESTRIAN

**S23 D** PEDESTRIAN TRANSIT INFORMATION

Secondary Pole Signs

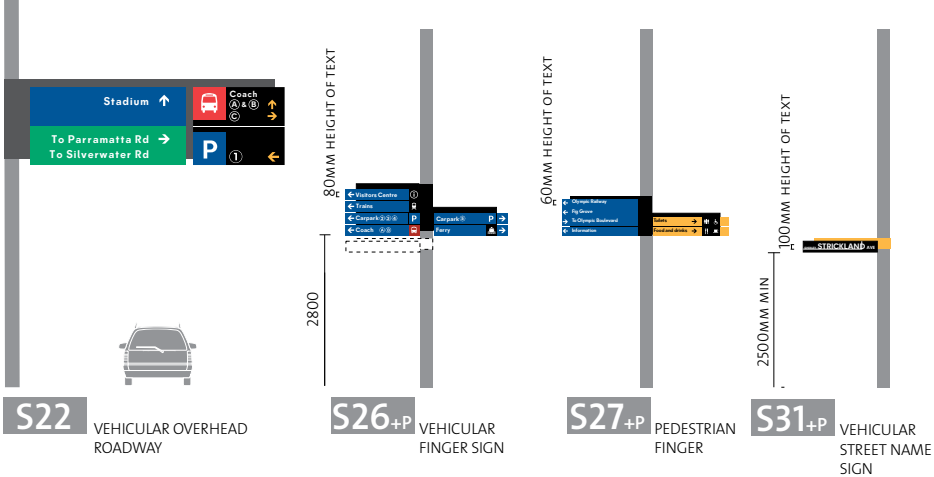

**S22** VEHICULAR OVERHEAD ROADWAY

**S26+P** VEHICULAR FINGER SIGN

**S27+P** PEDESTRIAN FINGER

**S31+P** VEHICULAR STREET NAME SIGN

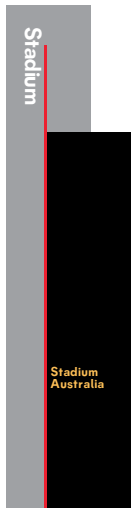

**S37** PRIMARY VENUE MARKER



**S37A** SECONDARY VENUE MARKER

Primary Blade Signs



**S36** PLAZA BUS STOP STATION

**S36 CD** COACH STATION

**S36 VD** CARPARK IDENTIFICATION

**S30** SECONDARY IDENTIFICATION MARKER

Primary Blade Signs

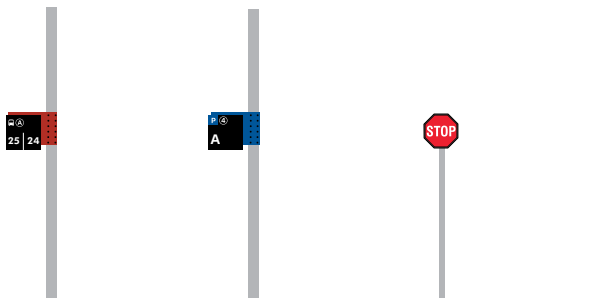

**S33 C+P** COACH BAY NUMBER

**S33 C+P** PARKING AREA NUMBER

**S43 +P** VEHICULAR-REGULATORY TRAFFIC SIGN

Secondary Pole Signs

## Paint

### 2 Pack Polyurethane

The recommended colours for sign panels are referred to as 'Homebush Blue', 'Homebush Yellow' and 'Homebush Red'.

Paint colour formulas can be obtained from Wattyl distributors using the names and code numbers listed.

### Micaceous Iron Oxide

The recommended colour for steel blades are referred to as 'Olympic black' and 'Interfine Light Metallic Grey'.

Paints can be obtained from International Protective Coatings using the names listed. See page S6 for paint specification.

### Anti-graffiti

All painted surfaces to have anti graffiti protective coating applied at 50% gloss.

### Vinyl

The recommended retroreflective vinyl for text and pictograms shall be Australian Standard Class 1A VIP Diamond grade and for fine lines shall be Australian Standard Class 2. Refer to design specification sheet S6 for more information.



WATTYL  
'HOMEBUSH BLUE' 5861



WATTYL  
'HOMEBUSH YELLOW' 5862



WATTYL  
'HOMEBUSH RED' 5860

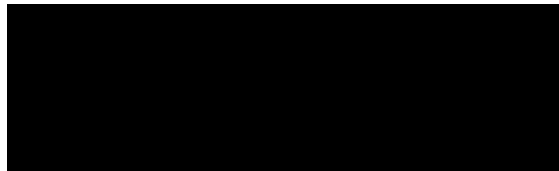

INTERNATIONAL  
PROTECTIVE COATINGS  
'OLYMPIC BLACK'



INTERNATIONAL  
PROTECTIVE COATINGS  
'GREY'

REFER TO DETAILS APPENDICES A AND B

Location

Across site.

Principle

Recommended colours for signage.

Pictograms are used as both a reinforcement of word messages and an independent order of informational elements in their own right.

In most instances, written notices convey information more efficiently than pictograms or symbols.

Pictograms are used for Signalling public facilities: toilets, trains, buses, taxis, disabled. Announcing regulations: no smoking, no entry. Signalling directions.

Colours First aid background to match PMS 347, Parking background Watty 'Hombush Blue,' Fire extinguisher Watty 'Homebush Red,' No smoking and no parking 'slash' and circular warning symbol Watty 'Hombush Red', No entry 'Watty' 'Hombush Red' circle and white rectangle, Coach background Watty 'Homebush Red', Regional bus background 'Homebush Yellow'.

Contractors shall only use this version of pictograms. Copies of these pictograms in either Mac or PC format are available from the SOPA.

The relationship of the pictogram to the background panel shall remain unchanged for its application to signage.

See design guidelines sheet S9 for setout information.

The International Pictograms Standard (incorporating D.O.T. Symbol Signs, ADA Symbols of Accessibility and other recognised standards) is from the book by Todd Pierce, Design Pacifica International, ST Publications, Cincinnati, Ohio.

## Services

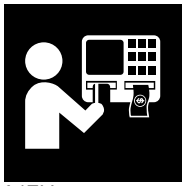

1 ATM



3 Bar

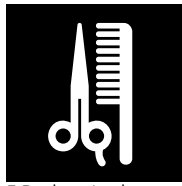

5 Barber / salon

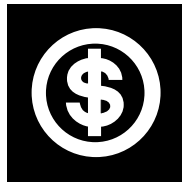

7 Cashier



9 Changing room



11 Chemist



13 Coffee shop

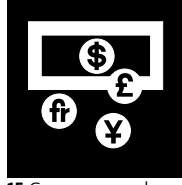

15 Currency exchange

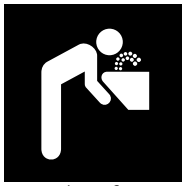

17 Drinking fountain



19 Information

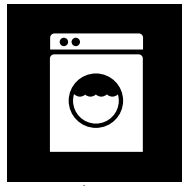

21 Laundry

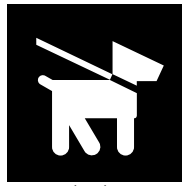

23 Leashed pets



25 Litter disposal

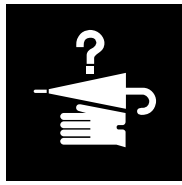

27 Lost and found



29 Mail



31 Parking



33 Pedestrian crossing



35 Restaurant



37 Shop



39 Shower



41 Snacks



43 Strollers

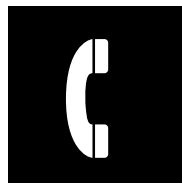

45 Telephone



47 Ticket machine



49 Toilets



51 Toilets female

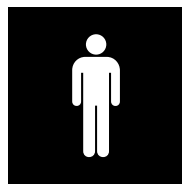

53 Toilets male

### Principle

Reinforcement for word message and an independent strata of information.

### Location

Across site.

REFER TO DETAILS APPENDICES A AND B

## Transportation

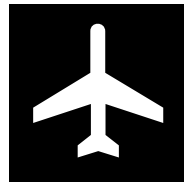

71 Air transportation

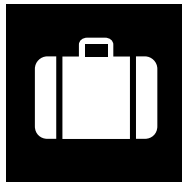

73 Baggage check in



75 Baggage lockers



77 Regional Bus

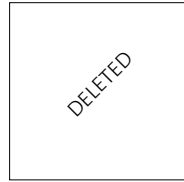

79



81 Car rental



83 Customs



85 Departing flights



87 Ground transportation



89 Ferry transportation

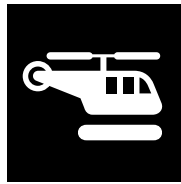

91 Heliport



93 Inspections

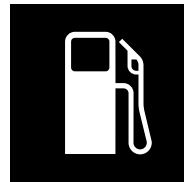

95 Petrol

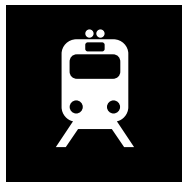

97 Rail transportation



99 Taxi



101 Coach

## Activities



111 Bicycle



113 Boat launch



115 Open fires allowed



117 Play ground



Directional

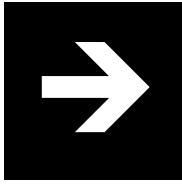

131 Right arrow

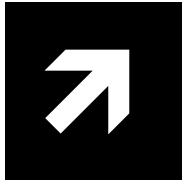

133 Forward and right arrow

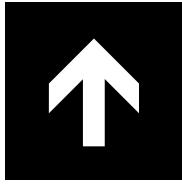

135 Up arrow

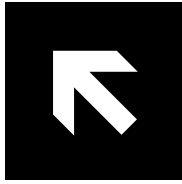

137 Forward and left arrow

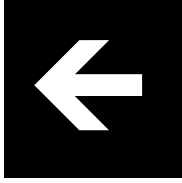

139 Left arrow

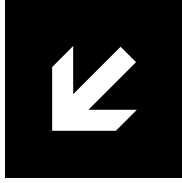

141 Left and down arrow

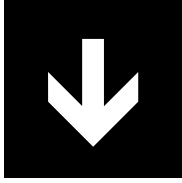

143 Down arrow

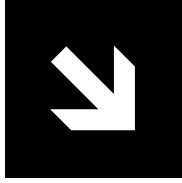

145 Right and down arrow

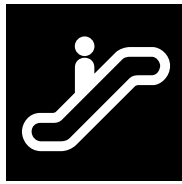

147 Escalator



149 Escalator down



151 Escalator up

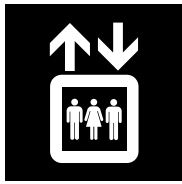

153 Elevator

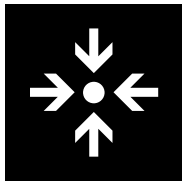

155 Meeting point

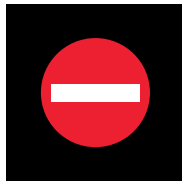

157 No entry

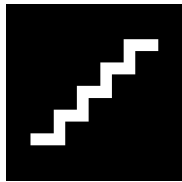

159 Stairs

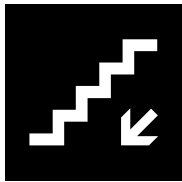

161 Stairs down

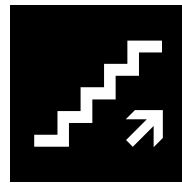

163 Stairs up

Principle

Reinforcement for word message and an independent strata of information.

Location

Across site.

REFER TO DETAILS APPENDICES A AND B

## Rubbish disposal

Background colour to match PMS 1945. Graphics to be white.

Background colour to match PMS 294. Graphics to be white.

Background colour to match PMS 446. Graphics to be white.



171 Paper and food



173 Recyclables



175 Rubbish

## Access



191 Hearing-impaired



193 Disabled access



195 Hearing- and speech-impaired telephone



197 Volume control telephone

Background colour to match B21 Ultramarine A5 2700.

## Regulatory



211 First aid



213 No bicycles



215 No fires



217 No fishing



219 No food



221 No parking



223 No pets



225 No running



227 No skateboarding



229 No smoking



231 No swimming



233 Slippery

### Principle

Reinforcement for word message and an independent strata of information.

### Location

Across site.

REFER TO DETAILS APPENDICES A AND B

### Numbers



For sign types S22, S23, S25, S26, S27 and S33

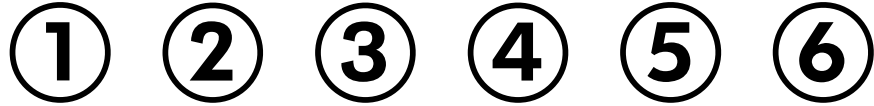

For sign types S23, S25, S26, S27 and S33



For sign type S33 (carpark 6 only)

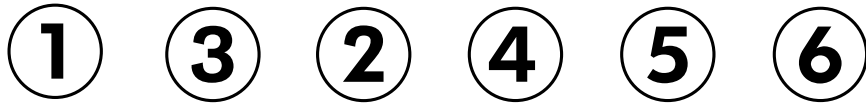

For sign type S22 (parking numbers only)

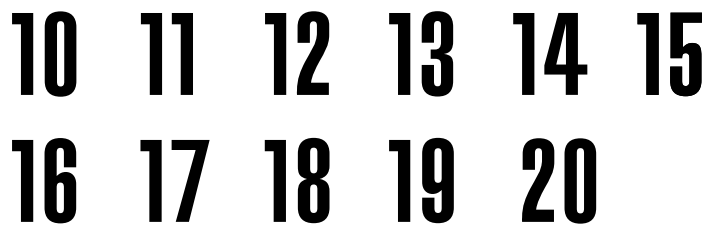

For sign type S20



For sign type S36 along the Olympic Boulevard (permanent)

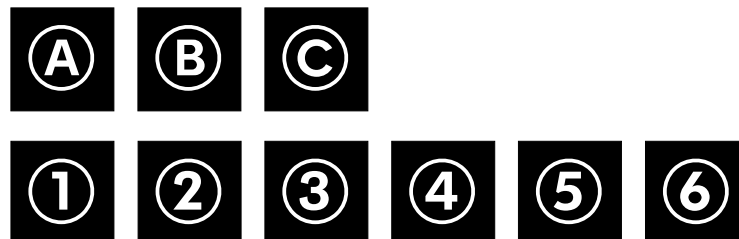

For sign types S36cd, S36vd and S36t

Location	Principle
Across site.	Reinforcement for word message and an independent strata of information.

## Arrows implementation

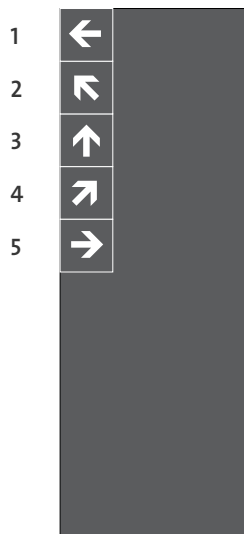

Diagrammatic sign elevation

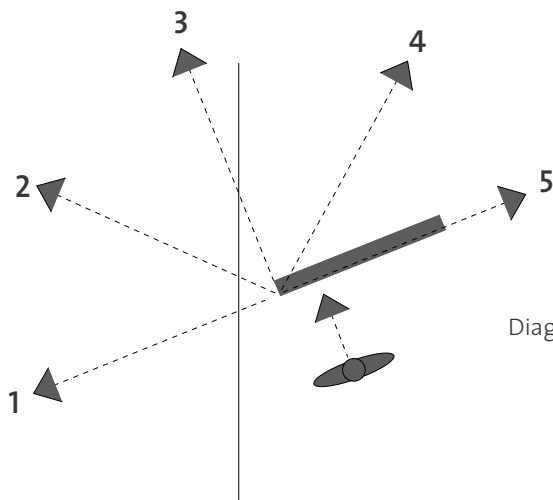

Diagrammatic sign plan view

## Pictograms

The correct selection and usage of arrows are important in conveying effective directions.

### Arrows Facing:

straight down; right and down; and left and down shall only be used where the information/destination is directly in front of the sign or in close proximity to it. These arrows should be used with great care.

Otherwise arrows shall be used to direct the public to destinations in the distance, as shown on the diagrammatic sign, below left.

The relationship of the pictogram to the background panel shall remain unchanged for its application to signage.

See design guidelines sheet S9 for setout information.

The diagrammatic sign elevation and plan view demonstrates the suggested relationship of the arrows to the direction of the information being represented.

### Principle

Reinforcement for word message and an independent strata of information.

### Location

Across site.

REFER TO DETAILS APPENDICES A AND B

## Materials and finishes

### Materials

Materials shall generally be those as specified within this document – steel, concrete, vinyl cut-out letters, acrylic, and sheet metal. See specific design specification sheet for sign type/material requirements.

### Finishes And Fixings Generally

Edges and surfaces should be clean, neat and free from burrs and indentations. Remove sharp edges to a fine pencil radius. All visible joints in materials shall be even, hairline joints unless noted otherwise for specific functional or visual requirements.

Match colour of sheets, extrusions and heads of fastenings in colour finished work. Unless otherwise noted on the drawings or in this specification, all exposed screwheads shall be countersunk phillips, 'posidrive', or socket head screws finishing flush with surface.

### Paint Finishes

It shall be the Contractor's responsibility to ensure that all surfaces are properly prepared and in suitable condition to receive the coating system prior to the first application as follows:

- Unprimed or damage primed steelwork shall be abrasive blasted, or power tool cleaned to near white metal, immediately prior to priming or spot priming.
- Primed steelwork shall be brushed down and degreased using white spirit.
- Galvanised steelwork scheduled to be paint finished shall be degreased using white spirit washed with water.

For steel surfaces, etch priming pretreatment should be fine sanded and three (3) coats of 2 pack polyurethane (approved example 'eurocyl' acrylic urethane) shall be applied to colour specified in the colour schedule. This surface should be lightly baked prior to application of screen-printed graphics. Finally apply a clear coat 2 pack polyurethane with UV stabilisers and lightly bake. All as per manufacturers' details and specifications. No visible rounding off on the edges shall occur or surface build ups generally at any stage of the coating procedure.

Painted finishes shall be checked with the control sample at SOPA for both colour and gloss level prior to manufacture.

- Where 'steel blade' components are noted on drawings International Protective Coatings 'Olympic Black' MIO shall be applied unless otherwise noted as MIO colour 'Light Metallic Grey'. Preparation of steel and application shall comply with manufacturers specifications.
- For ease of removing graffiti, International Protective Coatings 'Epivar' 50% gloss is to be applied to all exposed finished surfaces where MIO finish is specified. Watty Euroclear 50% gloss where 2 pack finish is specified.

### Screen Printing

Where noted on the drawings, all screenprinted graphics shall be applied according to the graphic specification using a screen of 120 threads per inch.

Vinyl graphics where noted on the drawings, Class 1 VIP Diamond grade for text and pictograms shall be used and for fine lines Australian Standard Class 2. Vinyls applied are to conform to AS 1906 part 1 unless otherwise noted.

### Cut-out Metal Lettering

All corners and edges of finished letter forms, numerals, arrows, pictograms, logo types or other symbols shall be sharp and true to the selected typeface or artwork with accurate, even curves and serifs where applicable.

When using laser cutting techniques, care shall be taken that the cut edges are not overheated, and the speed of cutting adjusted to be as slow as is consistent with the achievement of a clean cut.

### Standards and Codes of Practice

All work and materials shall, except where otherwise noted in this specification, comply with the latest editions of all relevant Australian codes or standards.

### LED Display

It is noted in Access Australia's report on LED displays that red wave lengths are not as easily seen as yellow and green wave lengths, therefore all information displayed on LED's is to be yellow. Dynamic characters are to be suitable for outdoor use and provide superior colour luminance contrast. Night time and overcast conditions will require stepped lighting of the sign panel.

### Traffic Signage

RTA and other traffic regulatory signage shall be fixed to poles as documented for sign type S43.

## Finishes Summary

Sign Type	Location	Colour	Material/ Finish	Specification type
S20	Main panel	Black	MIO	MIO Olympic Black
	Illuminated 'i'	White	acrylic	rear illuminated opal acrylic
	Illuminated			
	Slats	Blue	vinyl	rear illuminated translucent
		Yellow	vinyl	rear illuminated translucent
		Red	vinyl	rear illuminated translucent
		White	acrylic	rear illuminated opal acrylic
		Black	vinyl	opaque
S22	Back panel Information	Black	vinyl	opaque
	Panel	Green	vinyl	A.S. Class 1 VIP Diamond grade
	Panel	Blue	vinyl	A.S. Class 1 VIP Diamond grade
	Text	White	vinyl	A.S. Class 1 VIP Diamond grade
	Panel	Black	paint	Satin acrylic enamel
	Arrows	Yellow	vinyl	A.S. Class 1 VIP Diamond grade
	Pictogram	Red	vinyl	A.S. Class 1 VIP Diamond grade
	Pictogram	Blue	vinyl	A.S. Class 1 VIP Diamond grade
S23/S25	Main panel	Black	MIO	MIO Olympic Black
	Slats	Blue	paint	'Homebush Blue', satin acrylic enamel
		Yellow	paint	'Homebush Yellow', satin acrylic enamel
		Red	screenprinted	'Homebush Red', satin acrylic enamel
		Black	screenprinted	Satin acrylic enamel
		White	screenprinted	Satin acrylic enamel
		Yellow	screenprinted	'Homebush Yellow', satin acrylic enamel
S26	Central panel	Black	MIO	'Homebush Blue', satin acrylic enamel
	Slats	Blue	vinyl	A.S. Class 1 VIP Diamond grade
		Red	vinyl	A.S. Class 1 VIP Diamond grade
		Yellow	vinyl	A.S. Class 1 VIP Diamond grade
		White	vinyl	A.S. Class 1 VIP Diamond grade
S27	Central panel	Black	MIO	MIO Olympic Black
	Slats	Blue	paint	'Homebush Blue', satin acrylic enamel
		Red	screenprinted	'Homebush Red', satin acrylic enamel
		Yellow	paint	'Homebush Yellow', satin acrylic enamel
		Yellow	screenprinted	'Homebush Yellow', satin acrylic enamel



Sign Type	Location	Colour	Material/ Finish	Specification type
S30	Main panel	Black	MIO	MIO Olympic Black
		White	vinyl	A.S. Class 1 VIP Diamond grade (text & graphics)
		White	vinyl	A.S. Class 2 (fine line)
S31	Central panel	Yellow	paint	'Homebush Yellow', satin acrylic enamel
	Slat	Black	MIO	MIO Olympic Black
	Text	White	vinyl	A.S. Class 1 VIP Diamond grade
S33b	Central panel	Yellow	paint	'Homebush Yellow', satin acrylic enamel
	Sign panel	Black	MIO	MIO Olympic Black
		White	vinyl	A.S. Class 1 VIP Diamond grade
S33c	Central panel	Blue	paint	'Homebush Red', satin acrylic enamel
	Sign panel	Black	MIO	MIO Olympic Black
		White	vinyl	A.S. Class 2 (fine line only)
S33v	Central panel	Blue	paint	'Homebush Blue', satin acrylic enamel
	Sign panel	Black	MIO	MIO Olympic Black
		White	vinyl	A.S. Class 1 VIP Diamond grade
S36bd	Central panel	White	vinyl	A.S. Class 2 (fine line only)
		Blue	vinyl	A.S. Class 1 VIP Diamond grade
		Yellow	vinyl	A.S. Class 1 VIP Diamond grade
	Main panel	Black	MIO	MIO Olympic Black
	Top Sq. panel	Yellow	paint	'Homebush Yellow', satin acrylic enamel
S36cd	Text	White	vinyl	A.S. Class 1 VIP Diamond grade
	Main panel	Black	MIO	MIO Olympic Black
	Top Sq. panel	Red	paint	'Homebush Red', satin acrylic enamel
S36t	Pictogram	White	acrylic	rear illuminated opal acrylic
	Text	White	vinyl	A.S. Class 1 VIP Diamond grade
	Main panel	Black	MIO	MIO Olympic Black
	Top Sq. panel	Blue	paint	'Homebush Blue', satin acrylic enamel
S36vd	Pictogram	White	acrylic	rear illuminated opal acrylic
	Text	White	vinyl	A.S. Class 1 VIP Diamond grade
	Main panel	Black	MIO	MIO Olympic Black
	Top Sq. panel	Blue	paint	'Homebush Blue', satin acrylic enamel
S37a	Pictogram	White	acrylic	rear illuminated opal acrylic
	Text	White	vinyl	A.S. Class 1 VIP Diamond grade
	Main panel	Black	MIO	MIO Olympic Black
S37a	Vert. text	White	acrylic	rear illuminated opal acrylic
	Horiz. Text	Yellow	screenprinted	'Homebush Yellow', satin acrylic enamel

Sign Type	Location	Colour	Material/ Finish	Specification type
S37	Central panel	Grey	MIO	MIO 'Interfine Light Metallic Grey'
	Vert. text	White	acrylic	rear illuminated opal acrylic
	Sign panels	Black	MIO	MIO Olympic Black
	Horiz. text	Yellow	screenprinted	'Homebush Yellow', satin acrylic enamel
S40	Sign panel	Black	paint	Satin acrylic enamel
		White	screenprinted	Satin acrylic enamel (pictogram)
		Yellow	paint	'Homebush Yellow', satin acrylic enamel
		Black	screen printed	Satin acrylic enamel (text)
		Blue	paint	Satin acrylic enamel
S41	Sign panel	Black	paint	Satin acrylic enamel
		Red	paint	'Homebush Yellow', satin acrylic enamel
		White	screenprinted	Satin acrylic enamel (text)
S47a/				
S47b	Main panel	bronze	brass	chemically bronzed brass
	graphics	etched		
S47c	Main panel	Grey	concrete	Dark grey pigment cast concrete
	Graphics	S.S.	S.S.	10mm thick stainless steel

## Graphic Setout

### Letter, Word and Line Spacing in Signage

When assembling letters into words, careful consideration must be given to the spaces between each character. As the forms of the letters are variable, so are the spaces – and a badly spaced word not only hinders legibility but is also visually irritating.

The principle of letter spacing is that words have to look visually correct and therefore the proportional relationship between the face of the letter, the counter and the space between letters and words is critical. Typography is an art, not a mechanical process, and should only be undertaken by an expert typographer.

The spaces between words should be the minimum necessary to separate them from one another, but at the same time should be sufficient to prevent them from merging together. The space between lines must be more than that between words to ensure that the eye can travel easily along each horizontal line of type and absorb the phrases in sequential order.

Back-illuminated letters such as translucent white letters on opaque black or colour backgrounds will in most instances require the subtle addition of space in order to compensate for light diffusion.

## Sign Slats

Page 2 of 2

Directional information to transport and venues shall be screen printed located at the top of the sign panel.

Directional information to general facilities, such as toilets, shall be located at the bottom of the sign panel. Text and arrows shall be screen printed black with a yellow background.

Regional Bus pictograms shall be white on yellow square and Coach pictogram white on a red square. Parking and Access pictograms shall be white on a blue square. All other transport pictograms shall be white on a black square.

Note that yellow slats are:

- always to be placed at the bottom when required.
- never used if a triple red slat is required.
- maximum number of yellow slats is two per sign.

Directional information to Stadium Gates shall be placed at the bottom and triple slat high. Arrow is to be placed at the top right hand corner. Text and arrow shall be white on red background watty 'Homebush Red'.

### Specific Details

Typeface	S1
Colour	S2
Pictograms	S3, S5, S7

## Other Events and Venues

Directional information to facilities and venues.

## Toilets



Directional information to general facilities, such as toilets.

## Stadium Gates

# JKLMN

Directional information to stadium gates (triple height red slat).



Access pictogram to be white on watty "homebush blue" square.



Regional bus pictogram to be white on watty "homebush yellow" square.



Coach pictogram to be white on watty "homebush red" square.



Parking pictogram to be white on watty "homebush blue" square.

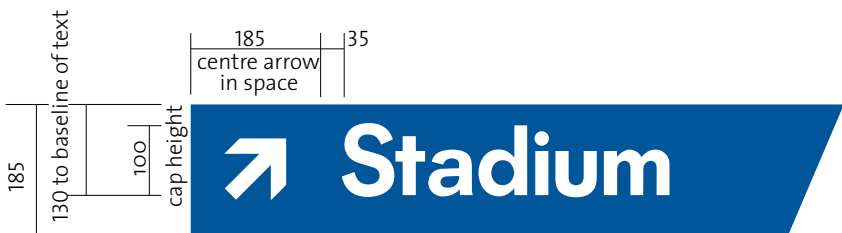
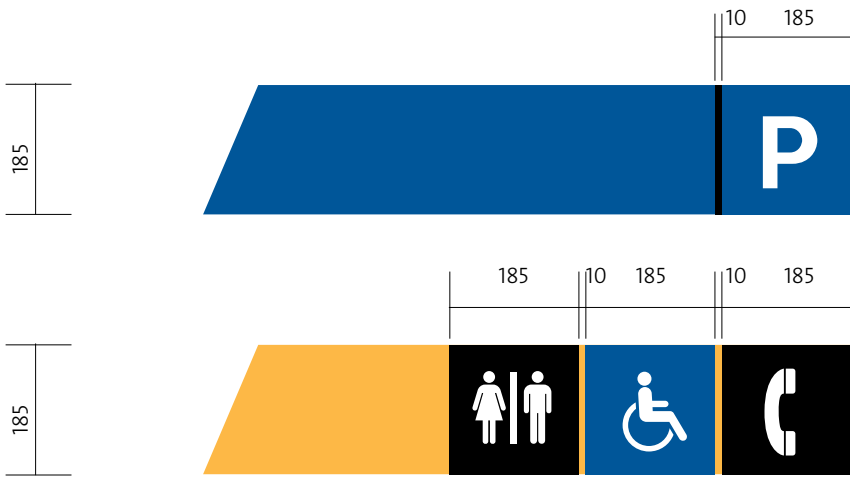

**Luminaire Type a**

**Sign Slats  
Non Illuminated  
(Screen Printed)**

Occur at signs S23, S23a, S25  
Page 1 of 3

Maximum number of slats per sign is 6, except when a red triple slat occurs maximum number of slats is 4, per side of sign.

Maximum number of pictograms per slat with text is 4 and without text is 5 (not including arrows).

Directional information to facilities and venues shall be located at the top of the sign panel. Arrows are always to be placed first (LHS of message).

Directional information to toilet and food facilities shall be located at the bottom of the sign panel.

For all S20, S23 and S25 sign types, six slats will be installed (except if a red triple slat is required). If six messages are not required Watty 'Homebush Blue' blank slats are to be installed.

Note that yellow slats are:

- always to be placed at the bottom when required.
- never used if a triple red slat is required.
- maximum number of yellow slats is two per sign.

**Specific Details**

Typeface	S1
Colour	S2
Pictograms	S3, S5, S7

**Principle**

Component of signage system.

**Location**

Occur at signs S23, S24 and S25.

REFER TO DETAILS APPENDICES A AND B

**Sign Slats**  
**Non Illuminated**  
**Triple Red Slat Option**  
**(Screen Printed)**

Ocur at signs S23 and S25  
 Page 2 of 3

Maximum number of slats per sign is 4.

Maximum number of pictograms per slat with text is 4 and without text is 5 (not including arrows).

Directional information to facilities and venues shall be located at the top of the sign panel. Arrows on blue slats only, are always to be placed first (LHS of message).

Directional information to Stadium Gates shall be placed at the bottom and triple slat high (including space between slats). Arrow is to be placed at the top right hand corner.

For all S20, S23 and S25 sign types, six slats will be installed (except if a red triple slat is required). If six messages are not required Watty! 'Homebush Blue' blank slats are to be installed. Note that yellow slats are: never used if a triple red slat is required.

**Specific Details**

Typeface	S1
Colour	S2
Pictograms	S3,S5,S7

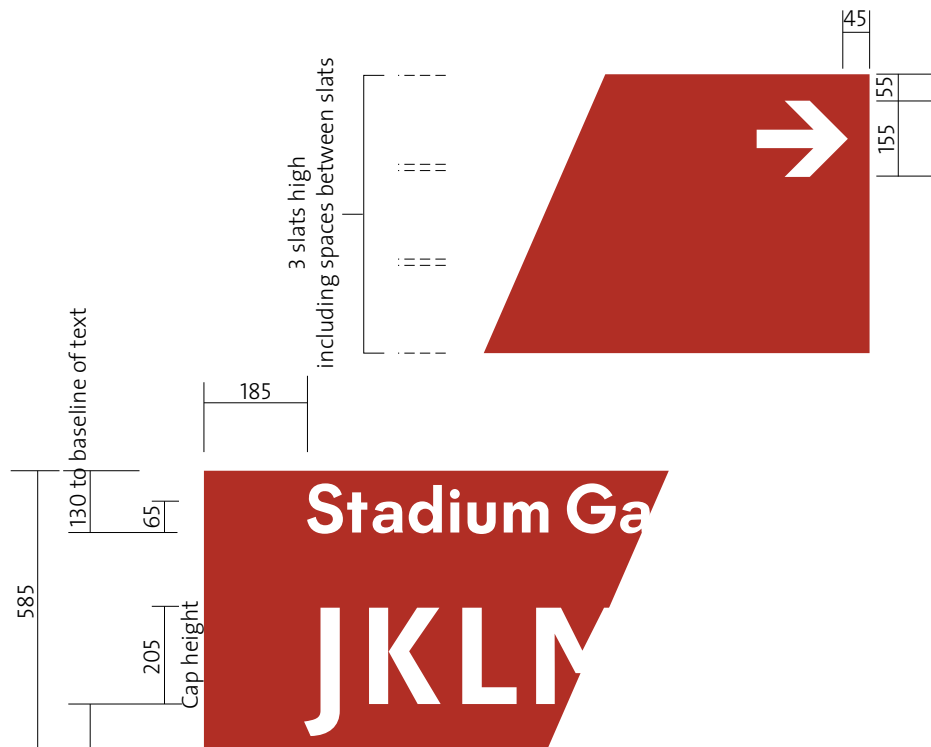
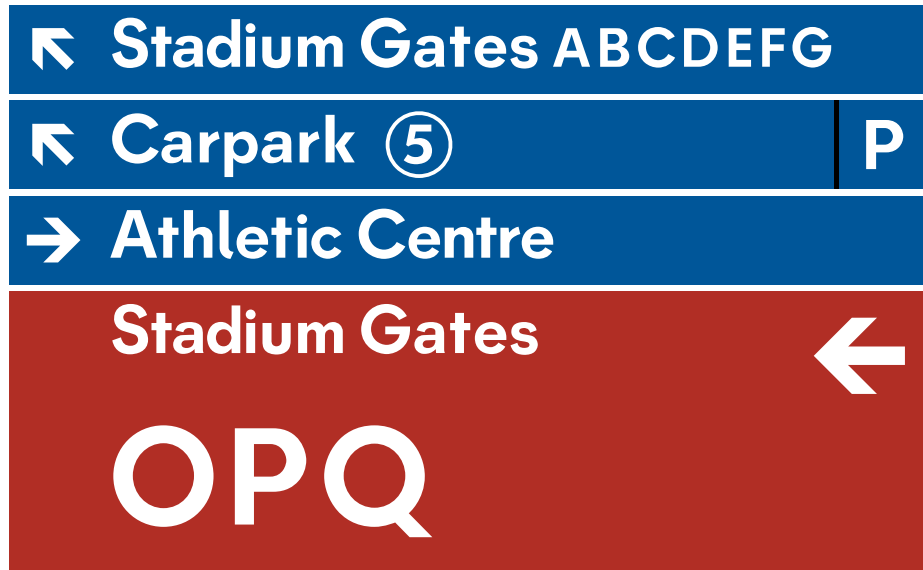

REFER TO DETAILS APPENDICES A AND B

**S9**

Location	Principle
Across site.	For use on custom designed light poles.

**Sign Slats  
Non Illuminated  
(Screen Printed)**

Occur at signs S23,S23a and S25  
Page 3 of 3

185 minimum distance  
To end of text



Slat with directional information to transport facility (maximum with pictogram)

Maximum number of slats per sign is 6, except when a red triple slat occurs where the maximum number of slats is 4, per side of sign.

Maximum number of pictograms per slat with text is 4 and without text is 5 (not including arrows).

Directional information to facilities and venues shall be located at the top of the sign panel. Arrows are always to be placed first (LHS of message).

Directional information to general facilities, such as toilets, shall be located at the bottom of the sign panel.

For all S20,S23 and S25 sign types, six slats will be installed (except if a red triple slat is required). If six messages are not required Watty! 'Homebush Blue' blank slats are to be installed.

Note that yellow slats are:

- always to be placed at the bottom when required.
- never used if a triple red slat is required.
- maximum number of yellow slats is two per sign.



Slat with directional information to venue (maximum without pictogram)

185 minimum distance  
To end of text



Slat with 4 pictograms (maximum with text)

**Specific Details**

Typeface	S1
Colour	S2
Pictograms	S3, S5, S7



Slat with 5 pictograms (maximum without text)



Triple red slat with directional information to stadium

Not to scale

<b>Principle</b>	<b>Location</b>	<b>REFER TO DETAILS APPENDICES A AND B</b>
For use on custom designed light poles.	Across site.	<h1>S9</h1>

**Sign Slats**  
**Non Illuminated**  
**(Reflective Vinyl)**

Occur at Sign S26 (Vehicular)  
Page 1 of 2

Maximum number of transport pictograms per slat is 1.

Maximum number of numbers in circles per slat is 4.

Arrows are to be placed in the direction in which the slat is pointing.

Directional information to venues and transport facilities shall only be listed. Information to all other facilities shall not be listed on this sign type.

Text and arrows shall be white retroreflective vinyl VIP diamond grade complying with AS 1906 part 1. Background shall be blue retroreflective vinyl VIP diamond grade.

Coach pictograms shall be white on a red square. Parking pictograms shall be white on a blue square. All other transport pictograms shall be white on a black square.

**Specific Details**

Typeface	S1
Colour	S2
Pictograms	S3, S5, S7
S26 layout options	S26
S26 slat configuration and orientation	S13

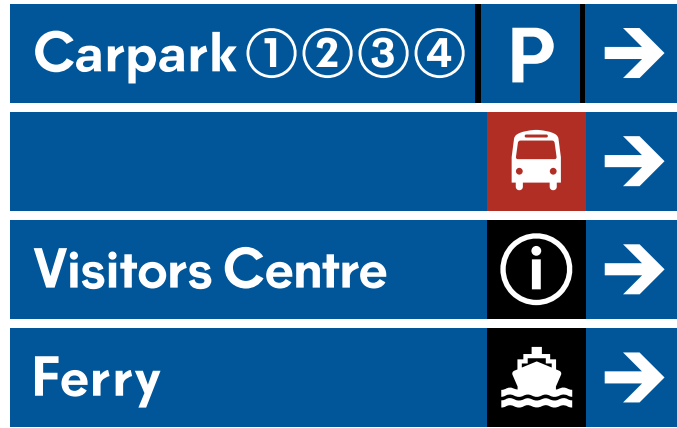

Arrows pointing right



Arrows pointing left

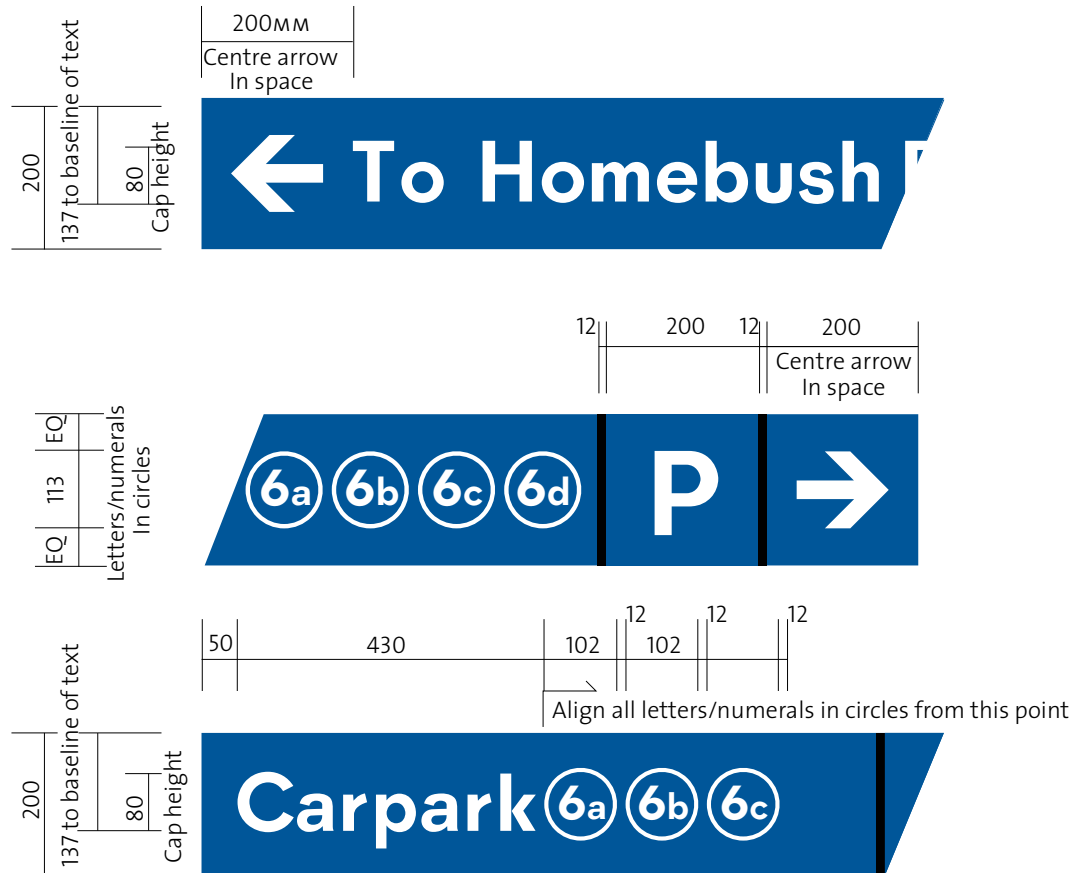

REFER TO DETAILS APPENDICES A AND B

**S10**

Location	Principle
Occur at signs S22 and S27 vehicular.	Component of signage system.





Slat with longest message  
Arrow pointing right



Slat with 4 parking pictograms (maximum)  
arrow pointing right



Slat with longest message  
Arrow pointing left



Slat with 4 parking pictograms (maximum)  
arrow pointing left

Not to scale

## Sign Slats Non Illuminated (Reflective Vinyl)

Occur at Sign S26 (Vehicular)  
Page 2 of 2

Maximum number of transport pictograms per slat is 1.

Maximum number of numbers in circles per slat 1 is 4.

Arrows are to be placed in the direction in which the slat is pointing.

Directional information to venues and transport facilities shall only be listed. Information to all other facilities shall not be listed on this sign type.

Text and arrows shall be white retroreflective vinyl VIP diamond grade complying with AS 1906 part 1. Background shall be blue retroreflective vinyl VIP diamond grade.

Coach pictograms shall be white on a red square. Parking and Access pictograms shall be white on a blue square. All other transport pictograms shall be white on a black square.

### Specific Details

Typeface	S1
Colour	S2
Pictograms	S3, S5, S7
S26 layout options	S26
S26 slat configuration and orientation	S13

### Principle

Component of signage system.

### Location

Occur at signs S22 and S27 vehicular.

REFER TO DETAILS APPENDICES A AND B

# S10

**Sign Slats  
Non Illuminated  
(Reflective Vinyl)**

Occur at Sign S27  
Page 1 of 2

Maximum number of slats per sign is 4.

Maximum number of pictograms per slat with text is 4.

Directional information to facilities and venues shall be screen printed located at the top of the sign panel. Arrows are to be placed in the direction in which the slat is pointing.

Directional information to general facilities, such as toilets, shall be located at the bottom of the sign panel.

Note that yellow slats are:

- always to be placed at the bottom when required.
- never used if a triple red slat is required.
- maximum number of slats is two per sign.

**Specific Details**

Typeface	S1
Colour	S2
Pictograms	S3,S5,S7
S27 slat configuration and orientation	S13

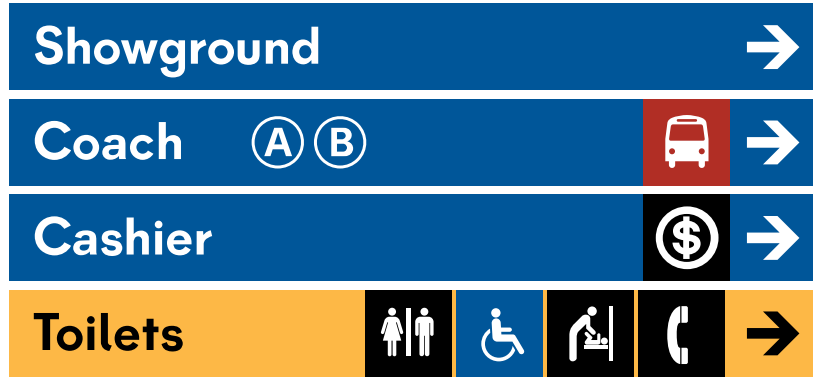

Arrows pointing right

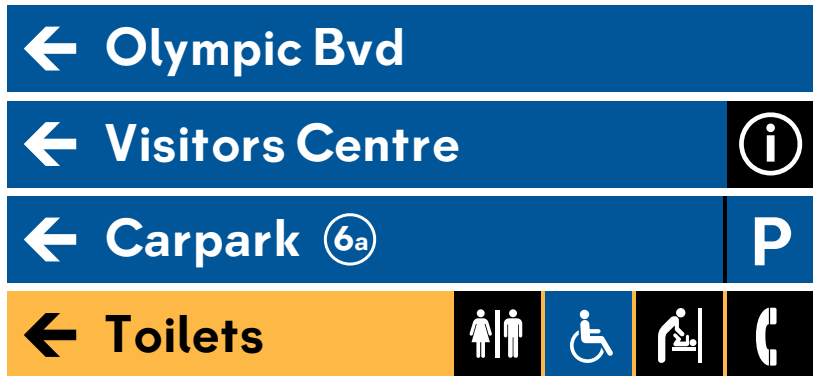

Arrows pointing left

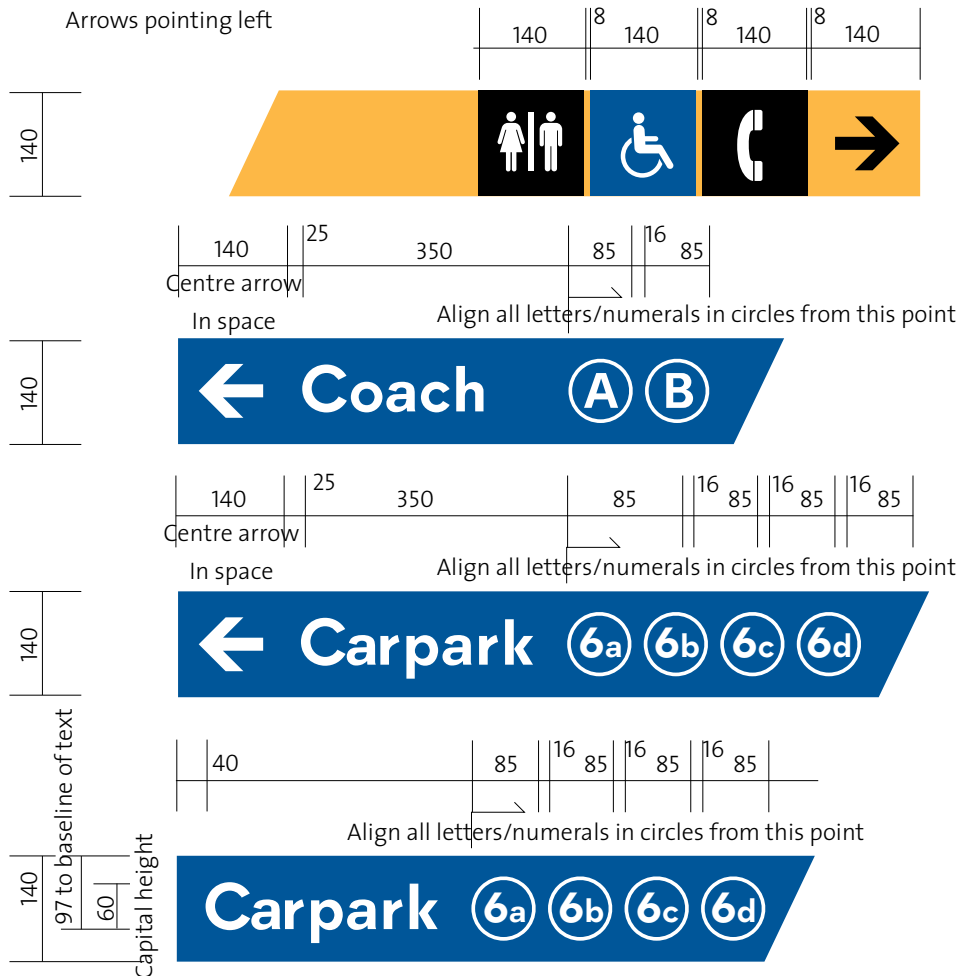

REFER TO DETAILS APPENDICES A AND B

**S11**

Location	Principle
Occur at signs S20 and S21	Component of signage system.



Slat with directional information to venue  
Arrow pointing right



Slat with 4 parking pictograms (maximum)  
arrow pointing right



Slat with 4 pictograms (maximum with text)  
arrow pointing left



Slat with 4 parking pictograms (maximum)  
arrow pointing left

140 minimum distance  
To end of text



Slat with 4 pictograms (maximum with text)  
arrow pointing right

Not to scale

Occur at Sign S27  
Page 2 of 2

Maximum number of slats per sign is 4.

Maximum number of pictograms per slat with text is 4.

Directional information to facilities and venues shall be screen printed located at the top of the sign panel. Arrows are to be placed in the direction in which the slat is pointing.

Directional information to general facilities, such as toilets, shall be located at the bottom of the sign panel.

For all S20, S23 and S25 sign types, six slats will be installed (except if a red triple slat is required). If six messages are not required Watty! 'Homebush Blue' blank slats are to be installed.

Note that yellow slats are:

- always to be placed at the bottom when required.
- never used if a triple red slat is required.
- maximum number of slats is two per sign.

**Specific Details**

Typeface	S1
Colour	S2
Pictograms	S3,S5,S7
S27 slat layout and configuration	S13

## Sign Slats Illuminated

Occur at Sign S20  
Page 1 of 3

Maximum number of slats per sign is 6.

Maximum number of pictograms per slat with text is 5 and without text is 4 (not including arrows).

Directional information to facilities and venues shall be located at the top of the sign panel.

Directional information to toilet and food facilities shall be located at the bottom of the sign panel.

For all S20, S23 and S25 sign types, six slats will be installed (except if a red triple slat is required). If six messages are not required Watty! 'Homebush Blue' blank slats are to be installed.

Note that yellow slats are:

- always to be placed at the bottom when required.
- never used if a triple red slat is required.
- maximum number of slats is two per sign.

### Specific Details

Typeface	S1
Colour	S2
Pictograms	S3, S5, S7

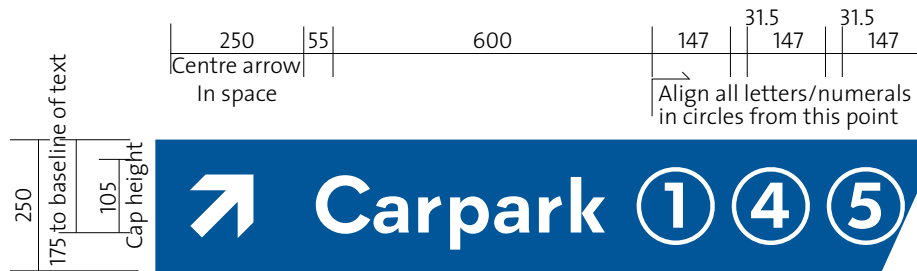
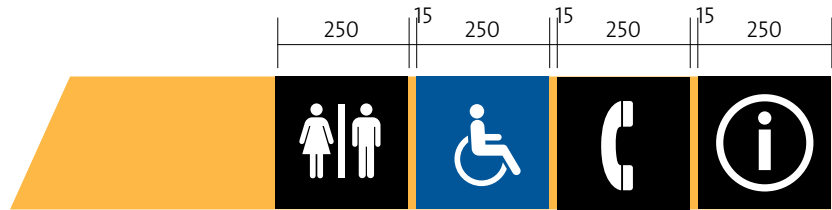

REFER TO DETAILS APPENDICES A AND B

# S12

Location

Occurs at sign S22.

Principle

Component of signage system.

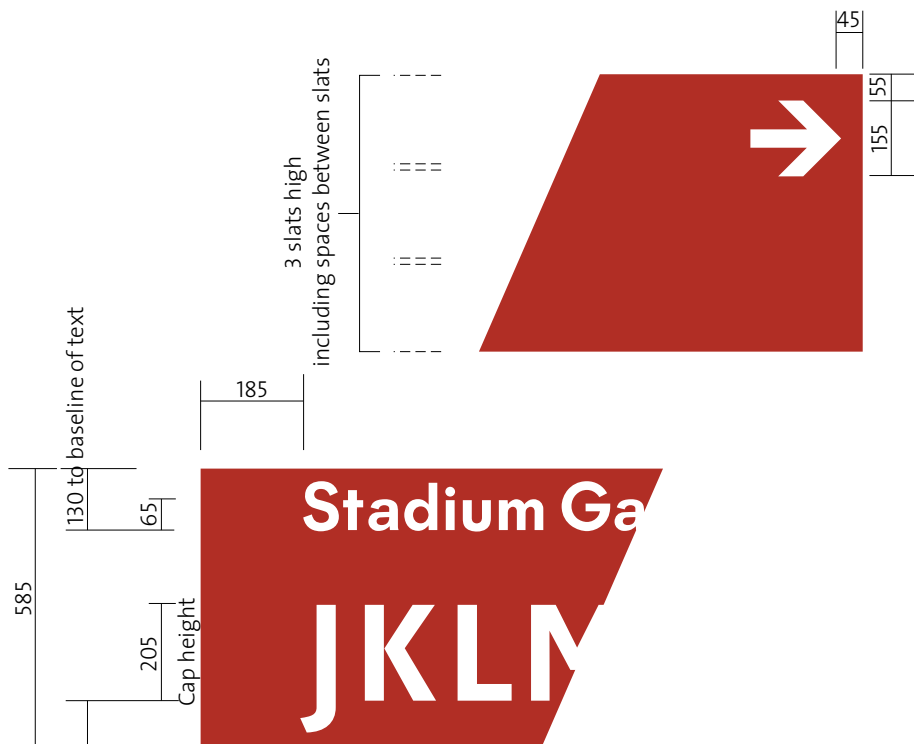

### Sign Slats Illuminated

Occur at Sign S20  
Page 2 of 3

Maximum number of slats per sign is 6.

Maximum number of pictograms per slat with text is 5 and without text is 4 (not including arrows).

Directional information to facilities and venues shall be located at the top of the sign panel.

Directional information to Stadium Gates is to be 'Homebush Red' with white text and arrow. Slat is to be equivalent to 3 slats high (including space between slats) and placed at the bottom.

For all S20, S23 and S25 sign types, six slats will be installed (except if a red triple slat is required). If six messages are not required Watty! 'Homebush Blue' blank slats are to be installed.

Note that yellow slats are:

- always to be placed at the bottom when required.
- never used if a triple red slat is required.
- maximum number of slats is two per sign.

#### Specific Details

Typeface	S1
Colour	S2
Pictograms	S3,S5, S7

<b>Principle</b>	<b>Location</b>	<b>REFER TO DETAILS APPENDICES A AND B</b>
------------------	-----------------	--

Component of signage system.	Occurs at sign S22.	
------------------------------	---------------------	--

**Sign Slats Illuminated**

Occur at Sign S20  
Page 3 of 3

Maximum number of slats per sign is 6.

Maximum number of pictograms per slat with text is 5 and without text is 4 (not including arrows).

Directional information to facilities and venues shall be located at the top of the sign panel.

Directional information to toilet and food facilities shall be placed at the bottom of the sign panel.

For all S20, S23 and S25 sign types, six slats will be installed (except if a red triple slat is required). If six messages are not required Watty! 'Homebush Blue' blank slats are to be installed.

Note that yellow slats are:

- always to be placed at the bottom when required.
- never used if a triple red slat is required.
- maximum number of slats is two per sign.

**Specific Details**

Typeface	S1
Colour	S2
Pictograms	S3,S5,S7



Slat with directional information to car park (maximum with pictogram)



Slat with directional information to venue (maximum without pictogram)

250 minimum distance  
To end of text



Slat with 4 pictograms (maximum with text)



Slat with 5 pictograms (maximum without text)



Triple red slat with directional information to stadium

Not to scale

REFER TO DETAILS APPENDICES A AND B

**S12**

Location	Principle
Occurs at sign S22.	Component of signage system.

**Sign Slats  
Non Illuminated  
(Reflective Vinyl)**

Occur at Sign S22  
Page 1 of 2

- All directional information on the left panel relates to venues and roads.

For information to venues the background is to be blue, for information to roads the background is to be green, text and arrows are to be white.

Background colours and graphics shall be applied retroreflective material class 1A VIP complying with AS 1906 part 1.

- All directional information on the right hand panel relates to transport and parking facilities.

Background is to be black, text and numeric/alphabetic pictograms are to be white and arrows are to be yellow.

All information (excluding black background) shall be applied retroreflective material class 1A VIP complying with AS 1906 part 1.

**Specific Details**

Typeface	S1
Colour	S2
Pictograms	S3,S5,S7
Retroreflective information	S6

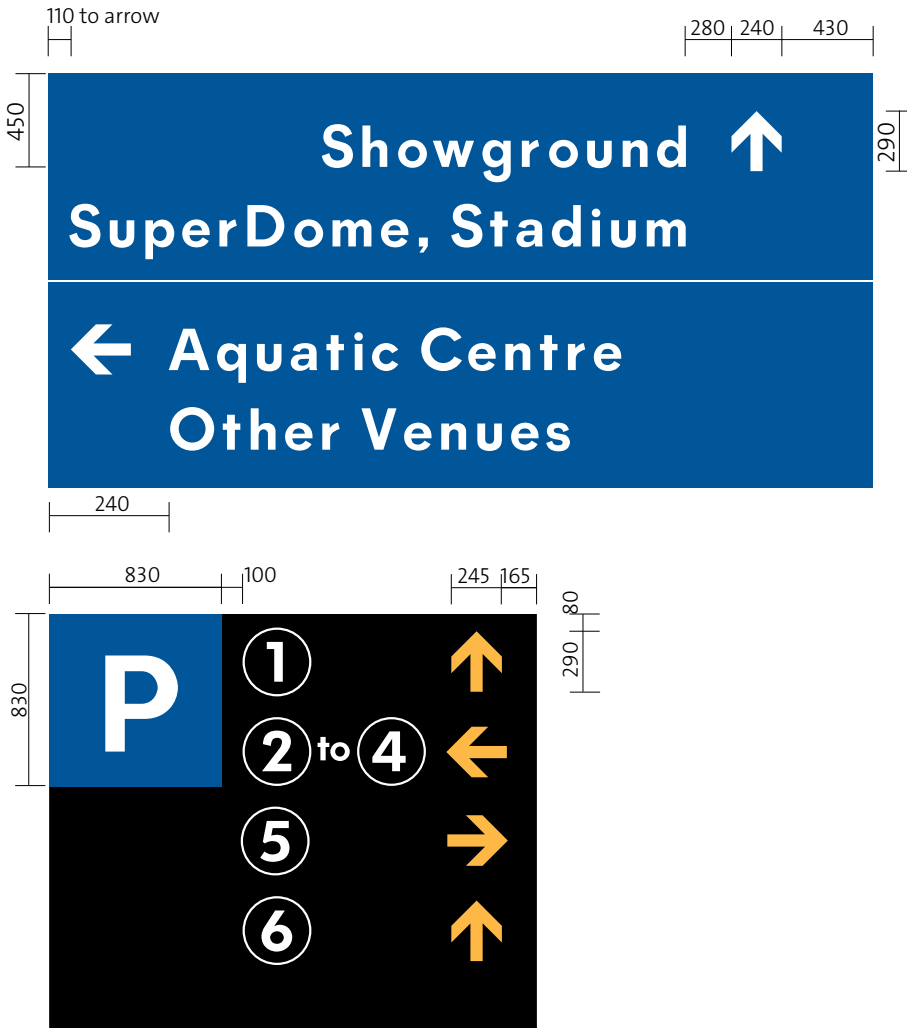
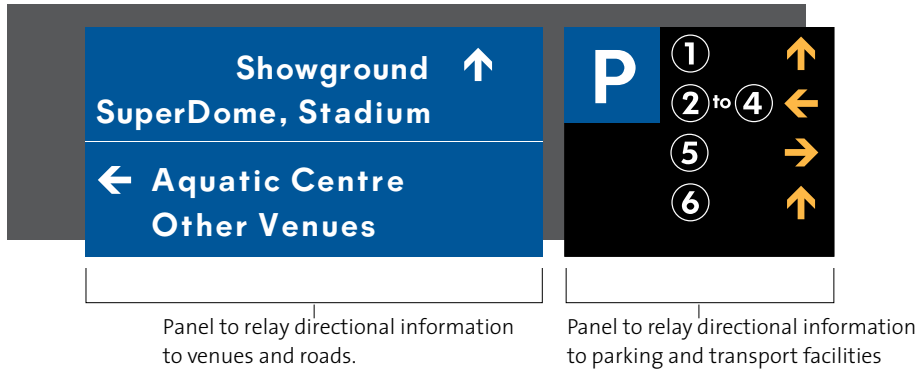

This is a typical graphic set out example only.  
Please note that due to varying messages no graphic set out is identical.  
General dimensioned set outs are shown.

**Sign Slats  
Non Illuminated  
(Reflective Vinyl)**

Occur at Sign S22  
Page 2 of 2

- All directional information on the left panel relates to venues and roads.

For information to venues the background is to be blue, for information to roads the background is to be green, text and arrows are to be white.

Background colours and graphics shall be applied retroreflective material class 1A VIP complying with AS 1906 part 1.

- All directional information on the right hand panel relates to transport and parking facilities.

Background is to be black, text and numeric/alphabetic pictograms are to be white and arrows are to be yellow.

All information (excluding black background) shall be applied retroreflective material class 1A VIP complying with AS 1906 part 1.

**Specific Details**

Typeface	S1
Colour	S2
Pictograms	S3,S5,S7
Retroreflective information	S6

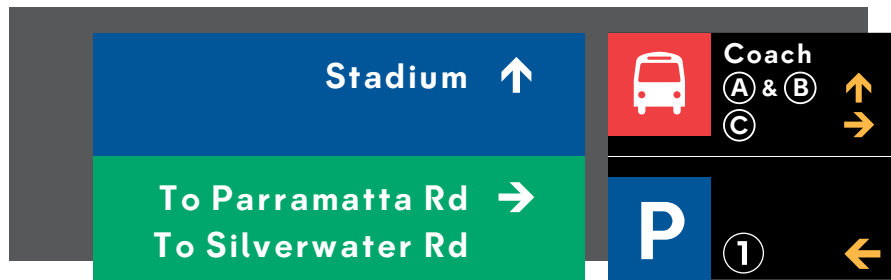
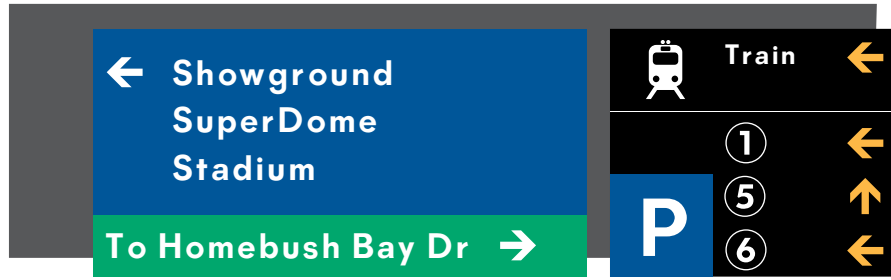

**General rules which apply for information relating to venues and roads:**

Arrows pointing right and straight ahead are to be placed right of the message and text is to be justified right.

Arrow pointing left are to be placed left of the message and text is to be justified left.



**Luminaire Type a  
Circulation  
Vehicular Bus Stop**

Page 1 of 2

**Function**

To identify transit pickup and setdown points, eg bus stops, taxi ranks, etc.

**Location**

At appropriate transit points fixed to posts or blade elements.

**Format**

As per graphic representation shown.

**Specific Details**

Arrows	S5
Pictograms	S3,S7
Colours	S2
Materials and finishes	S6



S33c Coach bay number

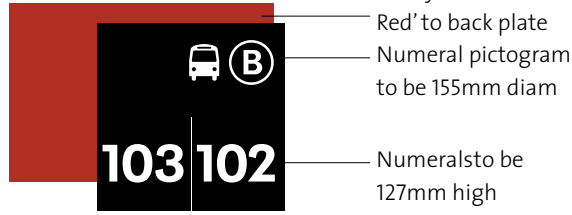

Wattyl 'Homebush Red' to back plate  
 Numeral pictogram to be 155mm diam  
 Numeralsto be 127mm high



S33v Car park bay number

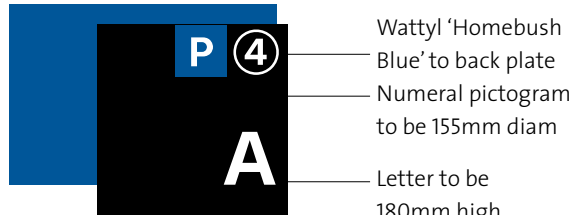

Wattyl 'Homebush Blue' to back plate  
 Numeral pictogram to be 155mm diam  
 Letter to be 180mm high



S33v Car park bay number

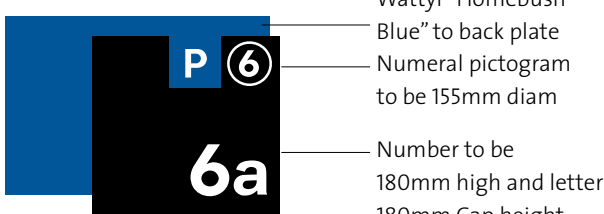

Wattyl "Homebush Blue" to back plate  
 Numeral pictogram to be 155mm diam  
 Number to be 180mm high and letter 180mm Cap height



S33v Taxi stand

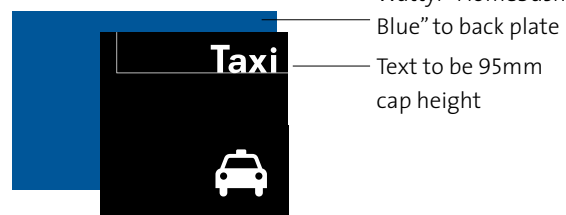

Wattyl "Homebush Blue" to back plate  
 Text to be 95mm cap height



S33v Exit

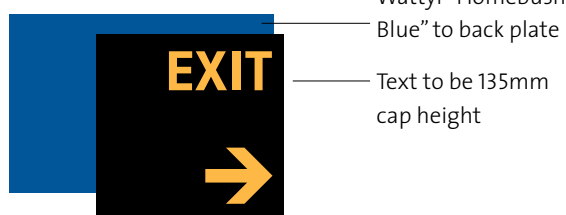

Wattyl "Homebush Blue" to back plate  
 Text to be 135mm cap height

## Circulation Vehicular Bus Stop

Page 2 of 2

### Function

To identify transit pickup and setdown points, eg bus stops, taxi ranks, etc.

### Location

At appropriate transit points fixed to posts or blade elements.

### Format

As per graphic representation shown.

### Specific Details

Arrows	S5
Pictograms	S3,S7
Colours	S2
Materials and finishes	S6

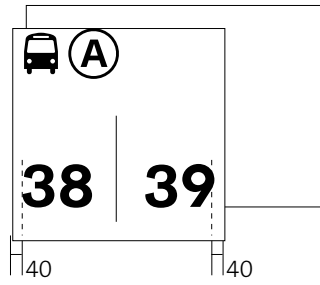

General set out

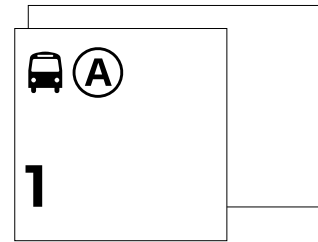

For single one or two digit numbers, vertical line is to be deleted

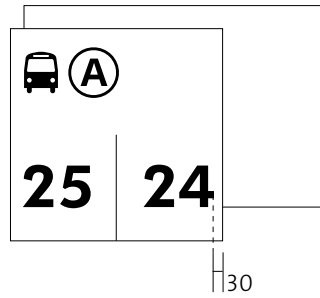

When number on the right is "4"

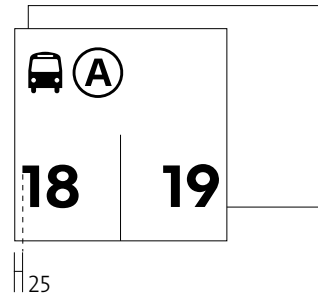

When number on the left is "1"

### Single and double digit number graphic set outs

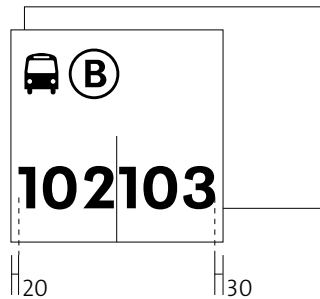

General set out

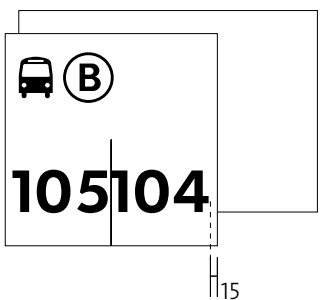

When number on the right is "4"

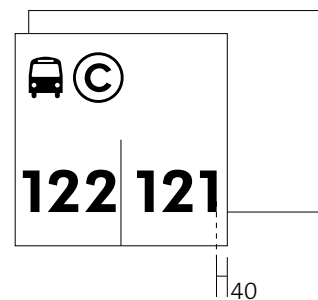

When number on the right is "1"

### Three digit number graphic set outs

**Sign Slats  
Non Illuminated  
(Reflective Vinyl)**

Occur at Sign S31 (Vehicular)

**Street Identification Sign**

Text shall be white retroreflective vinyl VIP diamond grade complying with AS 1906 part 1. Fine line shall be white retroreflective class 2 grade complying with AS 1906 part 1. Background shall be black.

**Specific Details**

Typeface	S1
Colour	S2



Rear view



Front view

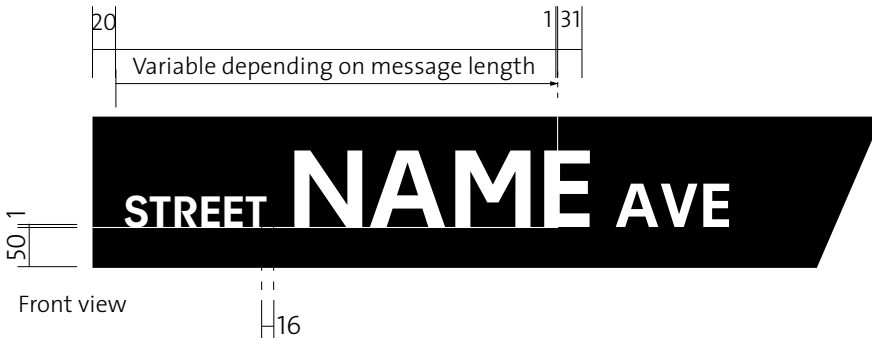

Front view



Rear view

## Sign Slats Configuration and Orientation

Signs S26, S27 and S31  
Page 1 of 9

S26 and S27 double sided blade.

Maximum no. of slats per sign face: 4.

Minimum no. of slats per sign face: 1.

Maximum no. of blades per pole: 4.

Note when S26 and S31 occur on the same pole:

Maximum no. of slats per sign face for S26: 3.

Maximum no. of blades per pole: 4.

The maximum configurations for the S26 and S27 is 4 blades with 8 slats per blade (ie 4 slats on each face of blade).

Mounting height to the bottom of sign types S26 and S27 is 2800mm.

### Specific Details

Typeface	S1
Colour	S2
Pictograms	S3,S5,S7
Graphic application	S10,S11,S15

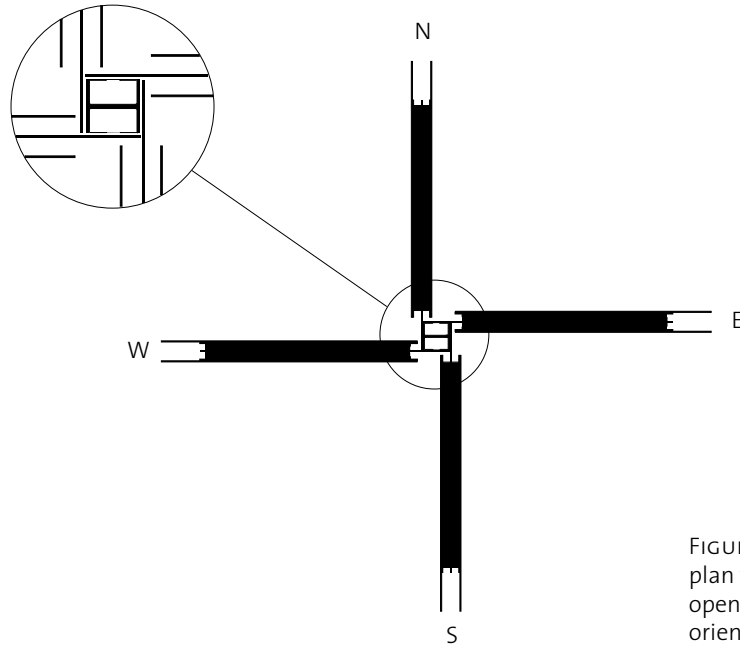

FIGURE 1  
plan view  
open flange of pole  
oriented North/South

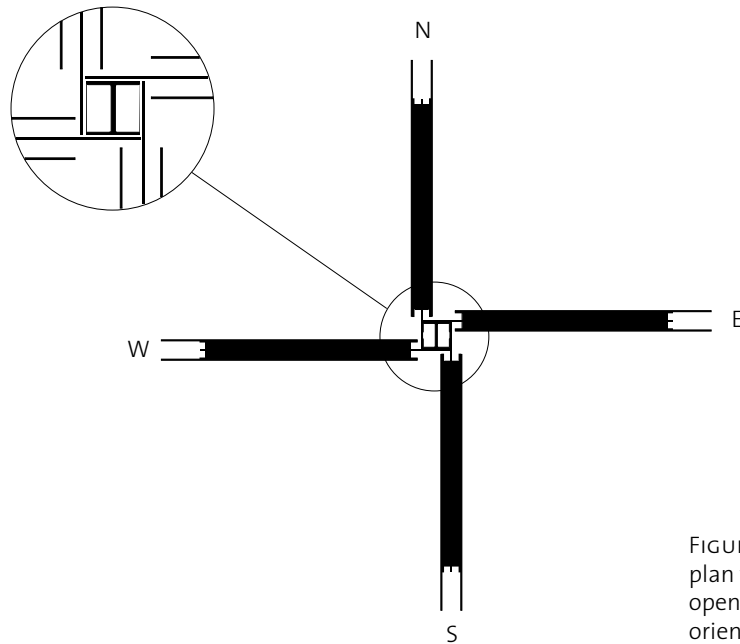
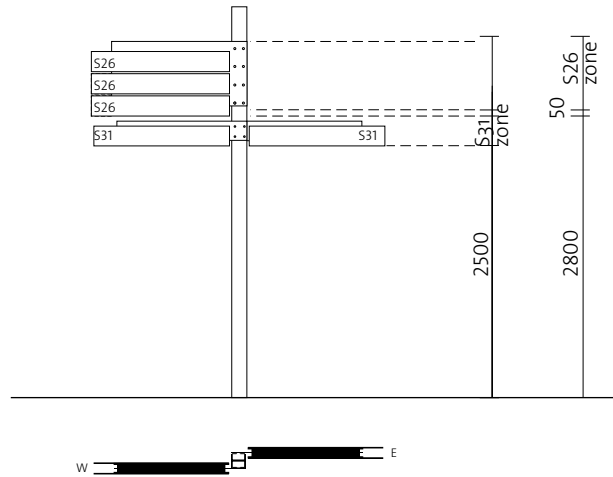

FIGURE 2  
plan view  
open flange of pole  
oriented East/West

1

Regardless of the orientation of the sign pole flange, finger signs are rotated at 90° increments around the pole, always starting from N, then to W, S and E. For example, North pointing sign is fixed to West face of pole.

Note: this diagram does not indicate any vertical hierarchy of sign placement on pole.



**FIGURE 1**  
elevation and plan view  
different zones for different sign types

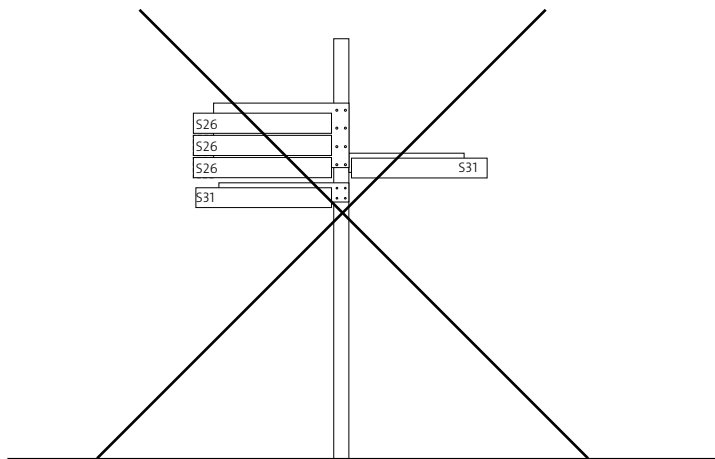

**FIGURE 2**  
elevation  
incorrect example

**2**  
Signs are grouped in zones, ie, 360 sections of the pole where only signs of one type may be placed. A zone cannot contain mixed sign types.

Street signs (S31) are always to be placed first, ie, on the lowest position on the pole. Street signs are mounted to allow 2500mm above finished ground level to the underside of the sign.

All vehicular signs (S26) are mounted to allow a minimum of 2800mm above finished ground level to the underside of the sign.

Where multiple S31 and S26 type signs are required on the pole, all S31s are to be mounted below the S26s. This maintains separate zones of S31 and S26 signs.

Two different sign types, such as S31 and S26, are never to be placed in the same zone.

S26 and S27 double sided blade.  
Maximum no. of slats per sign face: 4.  
Minimum no. of slats per sign face: 1.  
Maximum no. of blades per pole: 4.  
Note when S26 and S31 occur on the same pole:

Maximum no. of slats per sign face for S26: 3.

Maximum no. of blades per pole: 4.

The maximum configurations for the S26 and S27 is 4 blades with 8 slats per blade (ie 4 slats on each face of blade).

Mounting height to the bottom of sign types S26 and S27 is 2800mm.

**Specific Details**

Typeface	S1
Colour	S2
Pictograms	S3,S5,S7
Graphic application	S10,S11,S15

## Sign Slats Configuration and Orientation

### Signs S26, S27 and S31 Page 3 of 9

S26 and S27 double sided blade.

Maximum no. of slats per sign face: 4.

Minimum no. of slats per sign face: 1.

Maximum no. of blades per pole: 4.

Note when S26 and S31 occur on the same pole:

Maximum no. of slats per sign face for S26: 3.

Maximum no. of blades per pole: 4.

The maximum configurations for the S26 and S27 is 4 blades with 8 slats per blade (ie 4 slats on each face of blade).

Mounting height to the bottom of sign types S26 and S27 is 2800mm.

#### Specific Details

Typeface	S1
Colour	S2
Pictograms	S3,S5,S7
Graphic application	S10,S11,S15

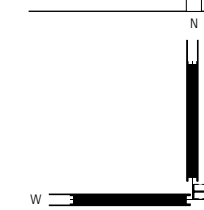
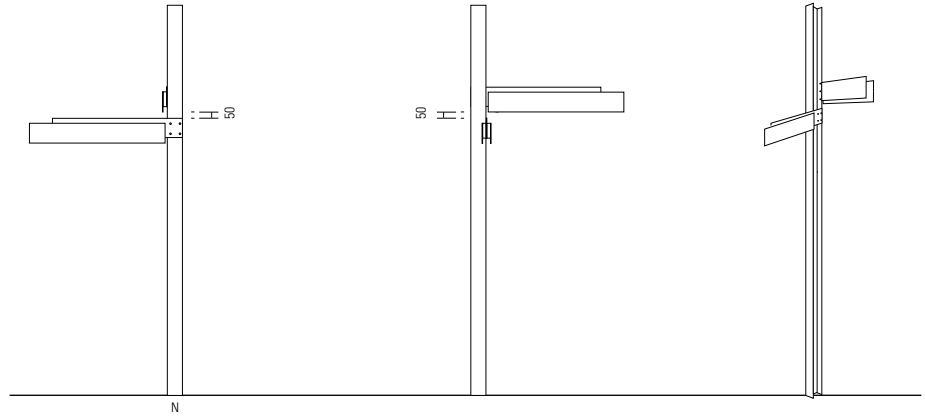

Figure 1  
plan and elevation  
90° to each other

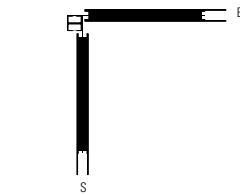

Figure 2  
plan and elevation  
90° to each other



Figure 3  
perspective view

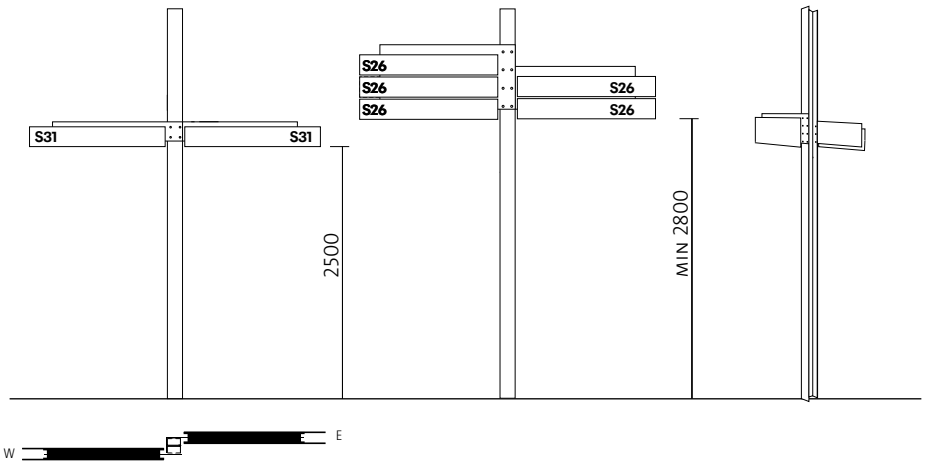

Figure 4  
plan and elevations  
180° to each other  
set out for S31 only  
(see point 4b for S31/S26 combination)

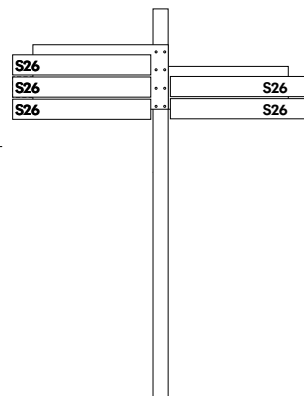

Figure 5  
plan and elevation  
180° to each other  
set out for S26 only

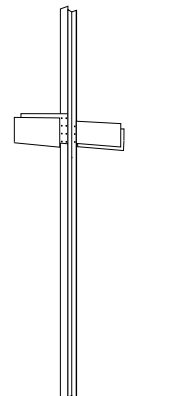

Figure 6  
perspective view

### 3

- a) Where signs are positioned at 90° to each other – for example, N/E – they are to be stacked (not mounted on the pole at the same level). Where signs are stacked, a 50mm gap is to be left between the top of the lower sign and the base of the sign above.
- b) Where signs are positioned at 180° to each other – for example, N/S – they are to be mounted to the front and rear of the pole respectively, parallel to each other. The bases of the signs are to align. See point 7 for exception to this rule.

## Sign Slats Configuration and Orientation

### Signs S26, S27 and S31 Page 4 of 9

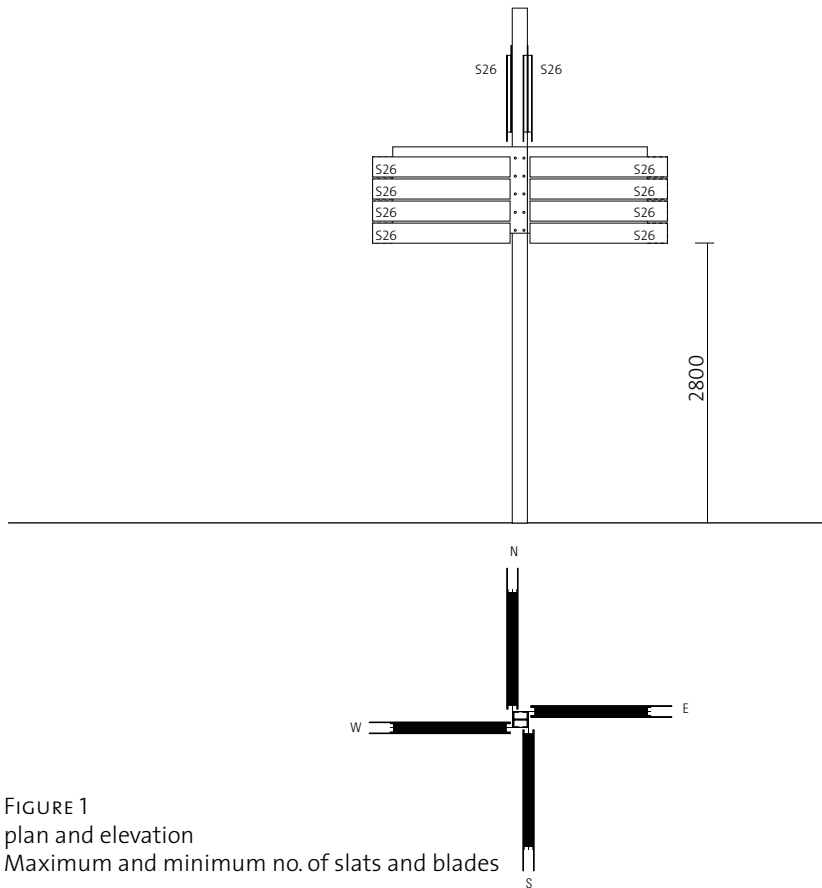

FIGURE 1  
plan and elevation  
Maximum and minimum no. of slats and blades

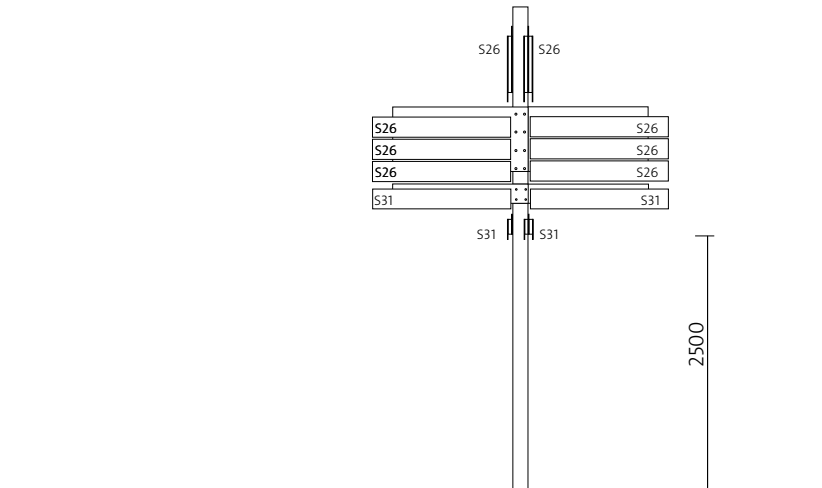

FIGURE 4  
(plan as above)  
Maximum no. of slats per sign face elevation

4

a) S26 double-sided blade

Maximum number of slats per sign face is 4

Minimum number of slats per sign face is 1

Maximum number of blades per pole is 4

b) S26 plus S31

Where these signs occur on the same pole,

the maximum number of slats per sign face for S26 is 3

S26 and S27 double sided blade.

Maximum no. of slats per sign face: 4.

Minimum no. of slats per sign face: 1.

Maximum no. of blades per pole: 4.

Note when S26 and S31 occur on the same pole:

Maximum no. of slats per sign face for S26: 3.

Maximum no. of blades per pole: 4.

The maximum configurations for the S26 and S27 is 4 blades with 8 slats per blade (ie 4 slats on each face of blade).

Mounting height to the bottom of sign types S26 and S27 is 2800mm.

#### Specific Details

Typeface S1

Colour S2

Pictograms S3,S5,S7

Graphic application S10,S11,S15

## Sign Slats Configuration and Orientation

### Signs S26, S27 and S31 Page 5 of 9

S26 and S27 double sided blade.

Maximum no. of slats per sign face: 4.

Minimum no. of slats per sign face: 1.

Maximum no. of blades per pole: 4.

Note when S26 and S31 occur on the same pole:

Maximum no. of slats per sign face for S26: 3.

Maximum no. of blades per pole: 4.

The maximum configurations for the S26 and S27 is 4 blades with 8 slats per blade (ie 4 slats on each face of blade).

Mounting height to the bottom of sign types S26 and S27 is 2800mm.

#### Specific Details

Typeface	S1
Colour	S2
Pictograms	S3,S5,S7
Graphic application	S10,S11,S15

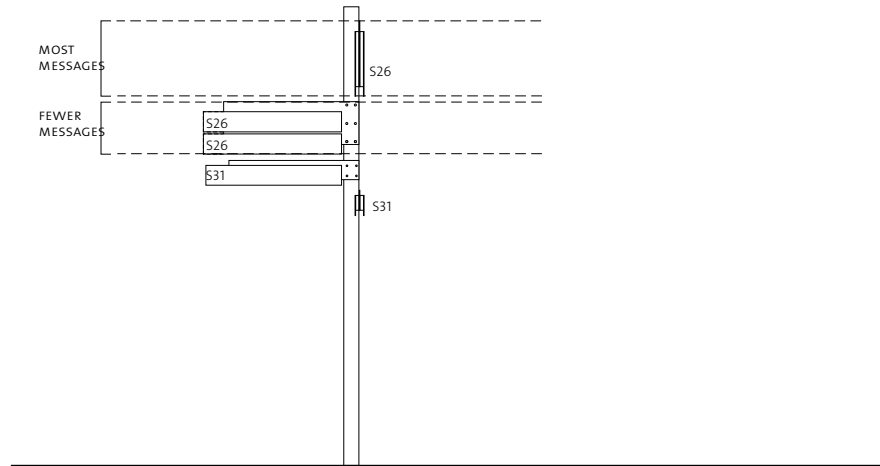

FIGURE 1  
Plan and elevation  
different sized message  
groups in different directions

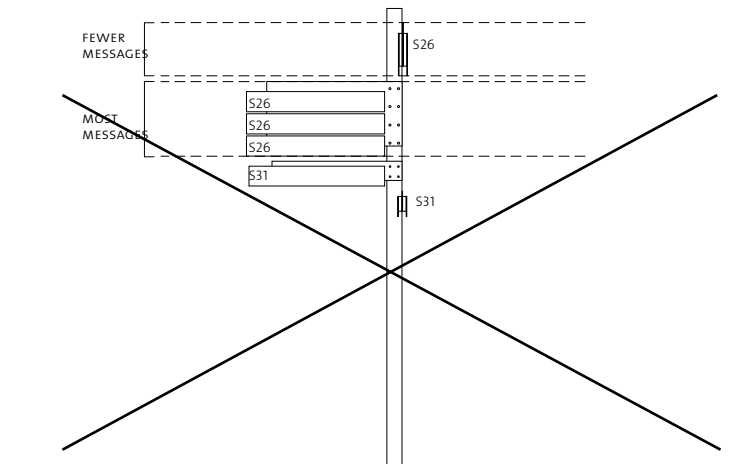

FIGURE 3  
incorrect example

#### 5a

Where there are different sized message groups pointing in different directions, the group with most message slats will be placed at the highest position on the pole, and the group with fewest message slats will be placed at the lowest position.



## Sign Slats Configuration and Orientation

### Signs S26, S27 and S31 Page 6 of 9

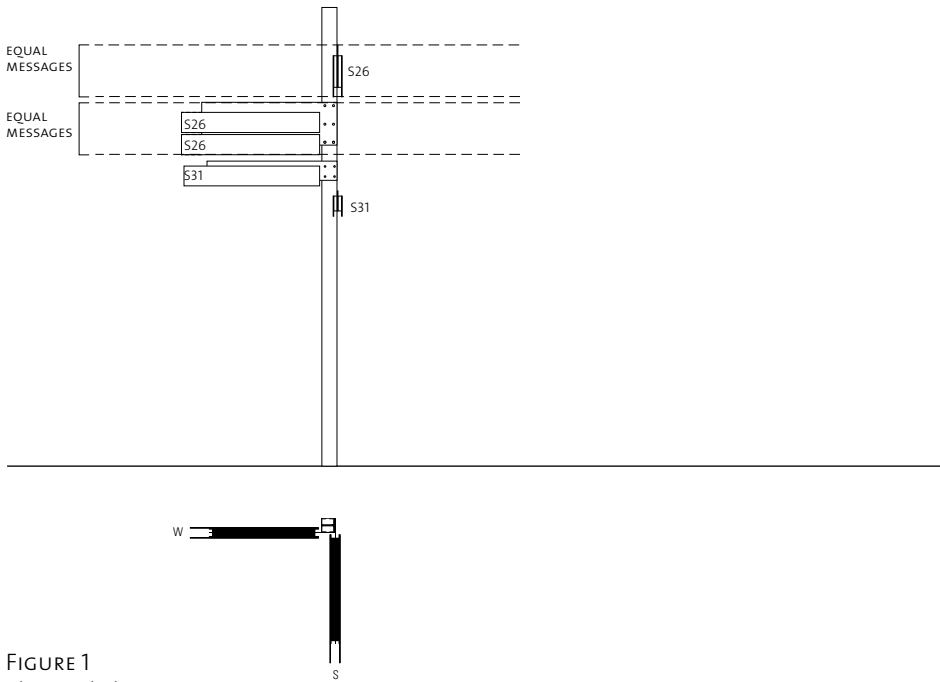

FIGURE 1  
Plan and elevation  
same sized message  
groups in different directions

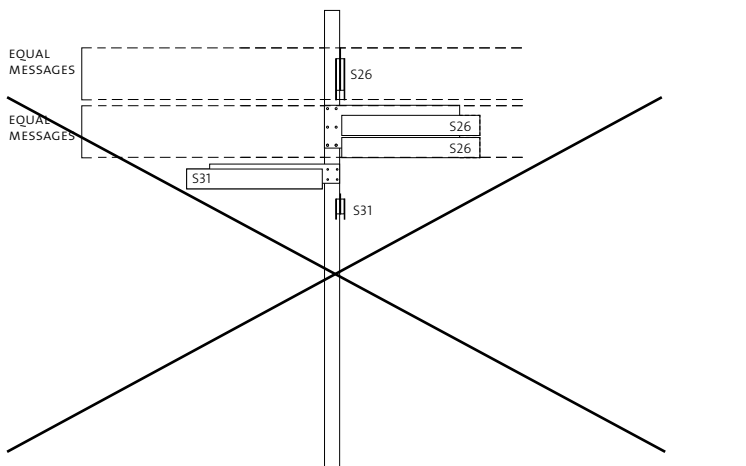

FIGURE 2  
incorrect example

#### 5b

Where equal-sized message groups, pointing in different directions, are mounted above a S31, those signs pointing in the same direction as the S31 street name sign are to be positioned directly above it. See figure 2

S26 and S27 double sided blade.

Maximum no. of slats per sign face: 4.

Minimum no. of slats per sign face: 1.

Maximum no. of blades per pole: 4.

Note when S26 and S31 occur on the same pole:

Maximum no. of slats per sign face for S26: 3.

Maximum no. of blades per pole: 4.

The maximum configurations for the S26 and S27 is 4 blades with 8 slats per blade (ie 4 slats on each face of blade).

Mounting height to the bottom of sign types S26 and S27 is 2800mm.

#### Specific Details

Typeface	S1
Colour	S2
Pictograms	S3,S5,S7
Graphic application	S10,S11,S15

# Sign Slats Configuration and Orientation

## Signs S26, S27 and S31 Page 7 of 9

- S26 and S27 double sided blade.
- Maximum no. of slats per sign face: 4.
- Minimum no. of slats per sign face: 1.
- Maximum no. of blades per pole: 4.
- Note when S26 and S31 occur on the same pole:
- Maximum no. of slats per sign face for S26: 3.
- Maximum no. of blades per pole: 4.

The maximum configurations for the S26 and S27 is 4 blades with 8 slats per blade (ie 4 slats on each face of blade).  
 Mounting height to the bottom of sign types S26 and S27 is 2800mm.

### Specific Details

Typeface	S1
Colour	S2
Pictograms	S3,S5,S7
Graphic application	S10,S11,S15

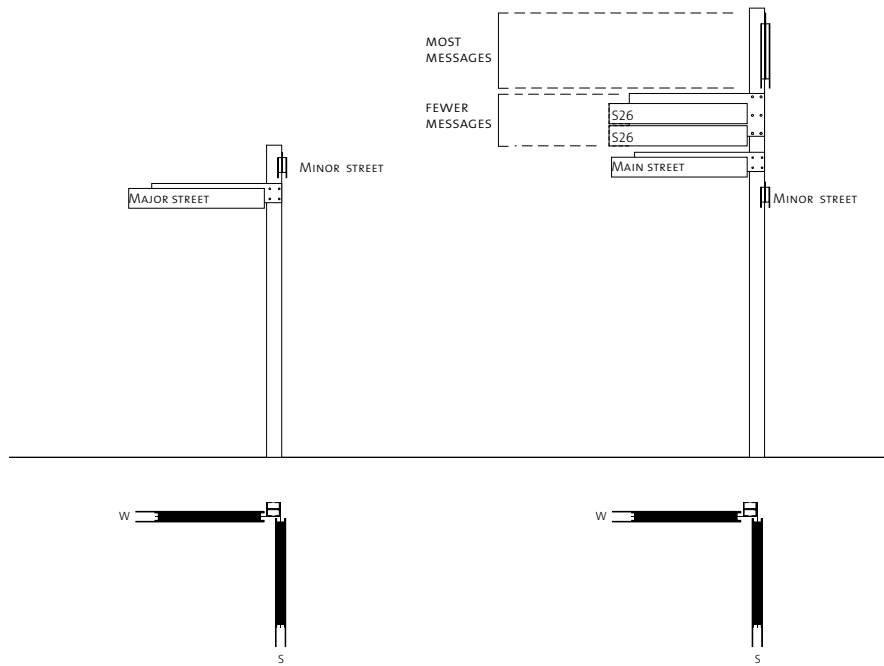

FIGURE 1  
 plan and elevation  
 major and minor road sign  
 see plan below

FIGURE 2  
 plan and elevation  
 major road sign  
 associated with grouped messages

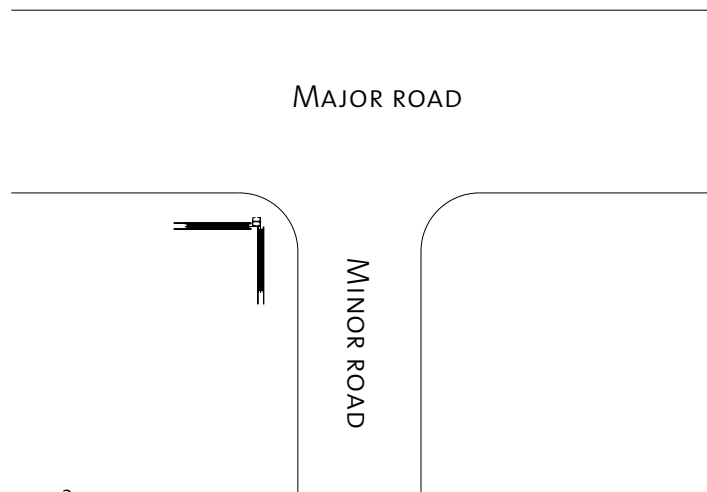

FIGURE 3  
 plan  
 roadside configuration

### 6

Major road signs take precedence and are always placed first, as the lowest sign – except where a message group pointing in the same direction as the major road sign makes it necessary for the major road sign to be included in that group of signs, in which case a minor street name sign may be placed below the major street sign

## Sign Slats Configuration and Orientation

### Signs S26, S27 and S31 Page 8 of 9

S26 and S27 double sided blade.

Maximum no. of slats per sign face: 4.

Minimum no. of slats per sign face: 1.

Maximum no. of blades per pole: 4.

Note when S26 and S31 occur on the same pole:

Maximum no. of slats per sign face for S26: 3.

Maximum no. of blades per pole: 4.

The maximum configurations for the S26 and S27 is 4 blades with 8 slats per blade (ie 4 slats on each face of blade).

Mounting height to the bottom of sign types S26 and S27 is 2800mm.

#### Specific Details

Typeface	S1
Colour	S2
Pictograms	S3,S5,S7
Graphic application	S10,S11,S15

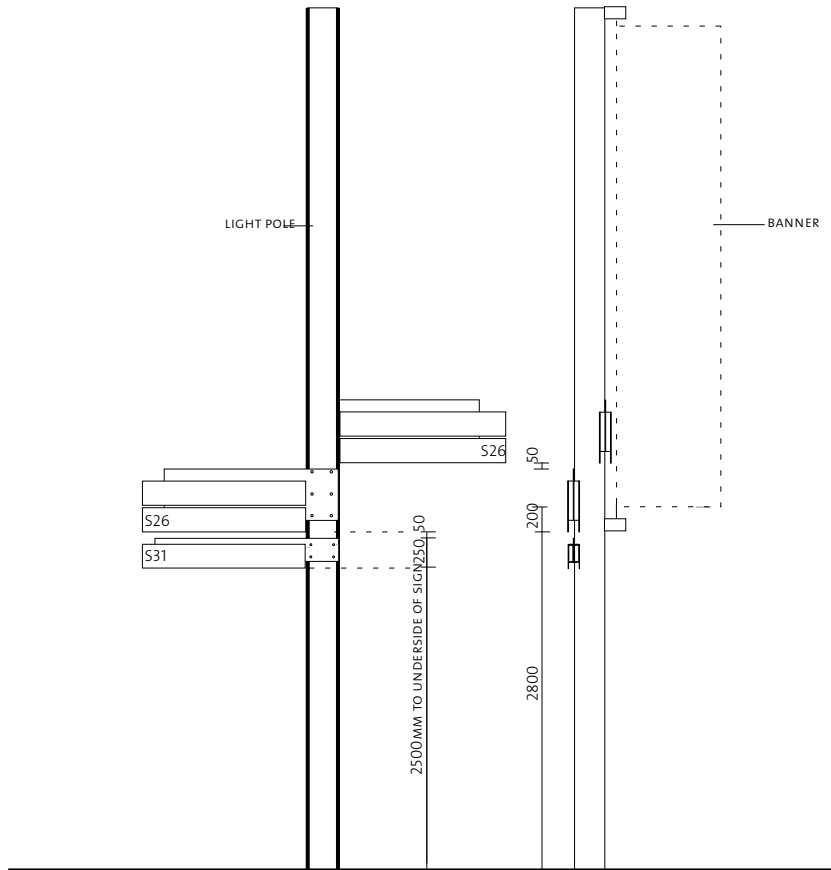

FIGURE 1(EXAMPLE 1)  
elevation  
sign mounted to light pole

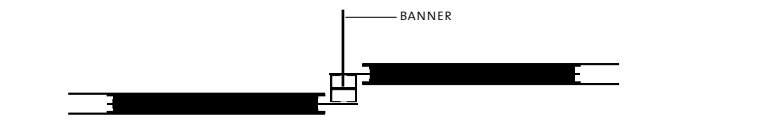

FIGURE 2(EXAMPLE 1)  
plan  
roadside configuration

#### 7 (example1)

Where signs are to be located on existing light poles with banners attached, signs at 180 degrees to each other are to be stacked due to location of bracket supports.

**Sign Slats  
Configuration and  
Orientation**

Signs S26, S27 and S31  
Page 9 of 9

7 (EXAMPLE 2)

S26 and S27 double sided blade.

Maximum no. of slats per sign face: 4.

Minimum no. of slats per sign face: 1.

Maximum no. of blades per pole: 4.

Note when S26 and S31 occur on the same pole:

Maximum no. of slats per sign face for S26: 3.

Maximum no. of blades per pole: 4.

The maximum configurations for the S26 and S27 is 4 blades with 8 slats per blade (ie 4 slats on each face of blade).

Mounting height to the bottom of sign types S26 and S27 is 2800mm.

**Specific Details**

Typeface	S1
Colour	S2
Pictograms	S3,S5,S7
Graphic application	S10,S11,S15

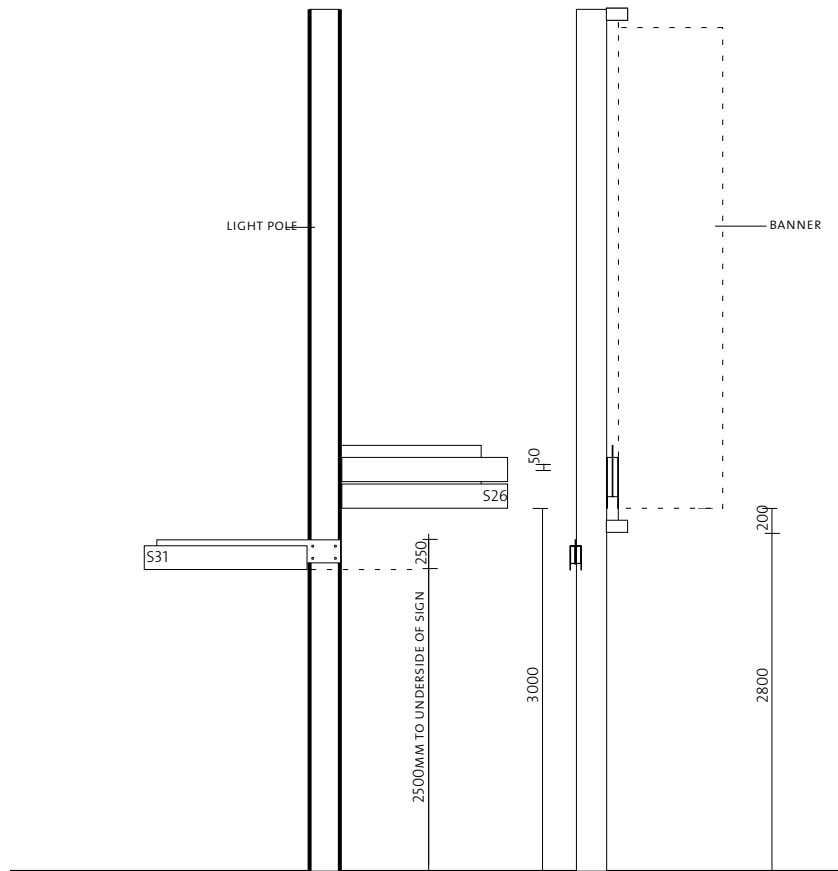

FIGURE 1(EXAMPLE 2)  
elevation  
sign mounted to light pole

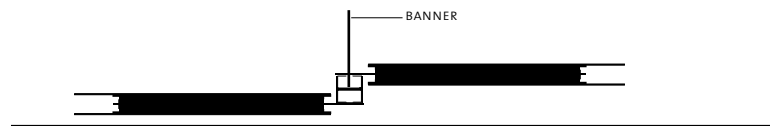

FIGURE 2(EXAMPLE 2)  
plan  
roadside configuration

**Function**

Large-format sign used where important directions require prominent signage.

May have detailed mapping, eg Showgrounds, located on steel black blade. Sign panel to be illuminated as well as number at top of the steel blade.

**Location**

At all pylons that flank the edge between the Olympic Plaza and the Olympic Boulevard only.

**Format**

As per graphic representation shown.

**Text Height**

Directional: 105mm

**Specific Details**

Arrows	S5
Pictograms	S3,S7
Colours	S2
Materials and finishes	S6
Slats	S12

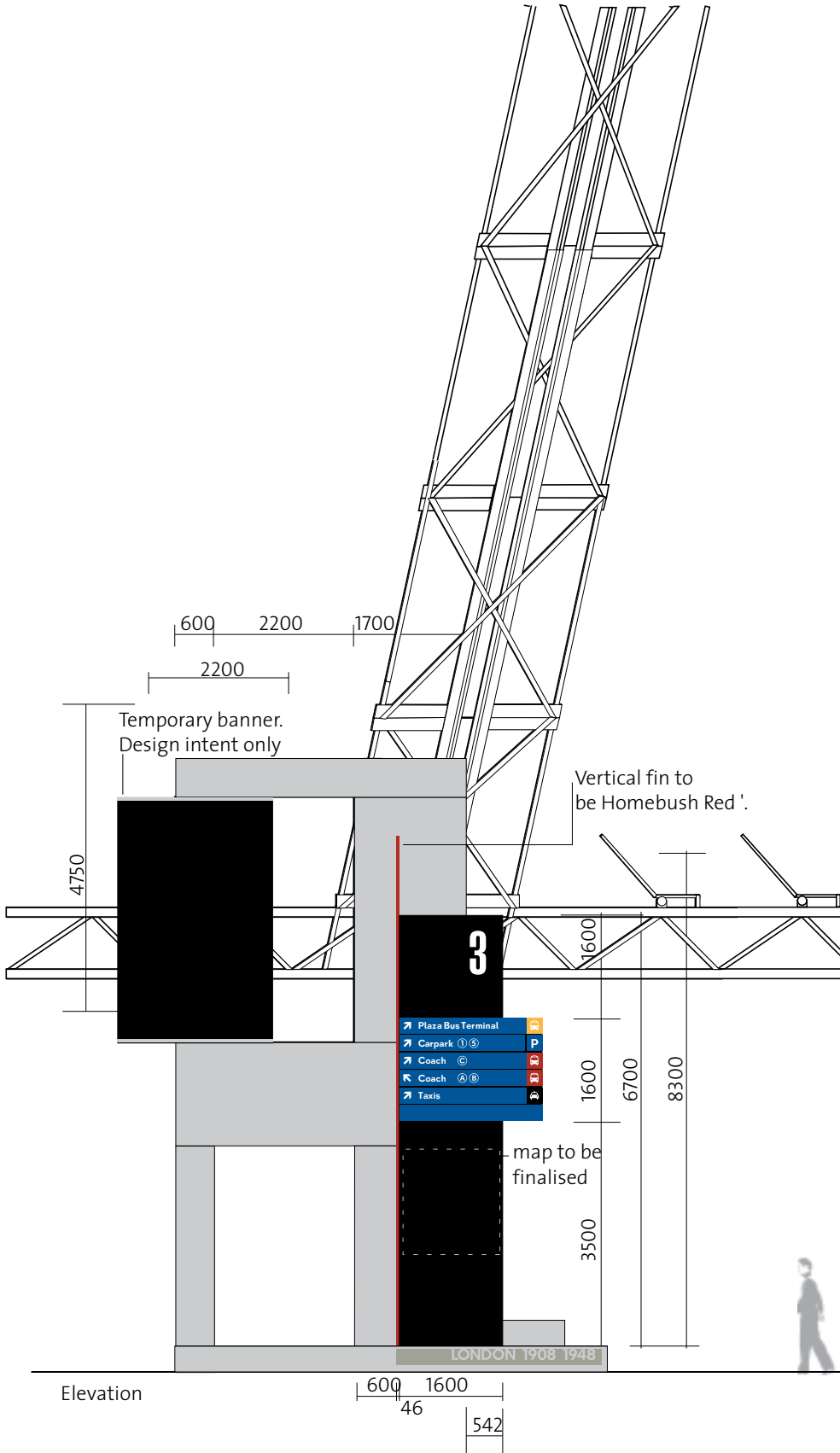

**Principle**

Large format sign used where important directions require prominent signage.

**Location**

Plaza pylons between Olympic Plaza and Olympic Boulevard.

REFER TO DETAILS APPENDICES A AND B

## Circulation Primary Pedestrian

Page 2 of 3

### Function

Large-format sign used where important directions require prominent signage.

May have detailed mapping, eg Showgrounds, located on steel black blade. Sign panel to be illuminated as well as number at top of the steel blade.

### Location

At all pylons that flank the edge between the Olympic Plaza and the Olympic Boulevard only.

### Format

As per graphic representation shown.

### Text Height

Directional: 105mm

### Specific Details

Arrows	S5
Pictograms	S3,S7
Colours	S2
Materials and finishes	S6
Slats	S12

- PYLON 1 **PARIS 1900 1924**
- PYLON 2 **ST LOUIS 1904**
- PYLON 3 **LONDON 1908 1948**
- PYLON 4 **STOCKHOLM 1912**
- PYLON 5 **ANTWERP 1920**
- PYLON 6 **AMSTERDAM 1928**
- PYLON 7 **LOS ANGELES 1932 1984**
- PYLON 8 **BERLIN 1936**
- PYLON 9 **HELSINKI 1952**
- PYLON 10 **MELBOURNE 1956**
- PYLON 11 **ROME 1960**
- PYLON 12 **TOKYO 1964**
- PYLON 13 **MEXICO CITY 1968**
- PYLON 14 **MUNICH 1972**
- PYLON 15 **MONTREAL 1976**
- PYLON 16 **MOSCOW 1980**
- PYLON 17 **SEOUL 1988**
- PYLON 18 **BARCELONA 1992**
- PYLON 19 **ATLANTA 1996**

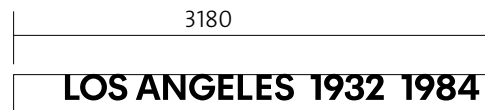

reverse elevation

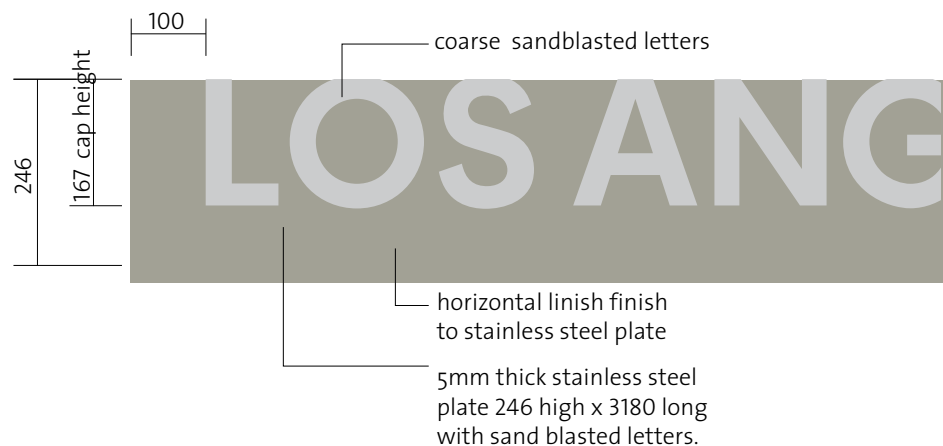
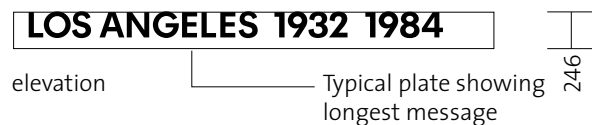

REFER TO DETAILS APPENDICES A AND B

### Location

Plaza pylons between Olympic Plaza and Olympic Boulevard.

### Principle

Large format sign used where important directions require prominent signage.

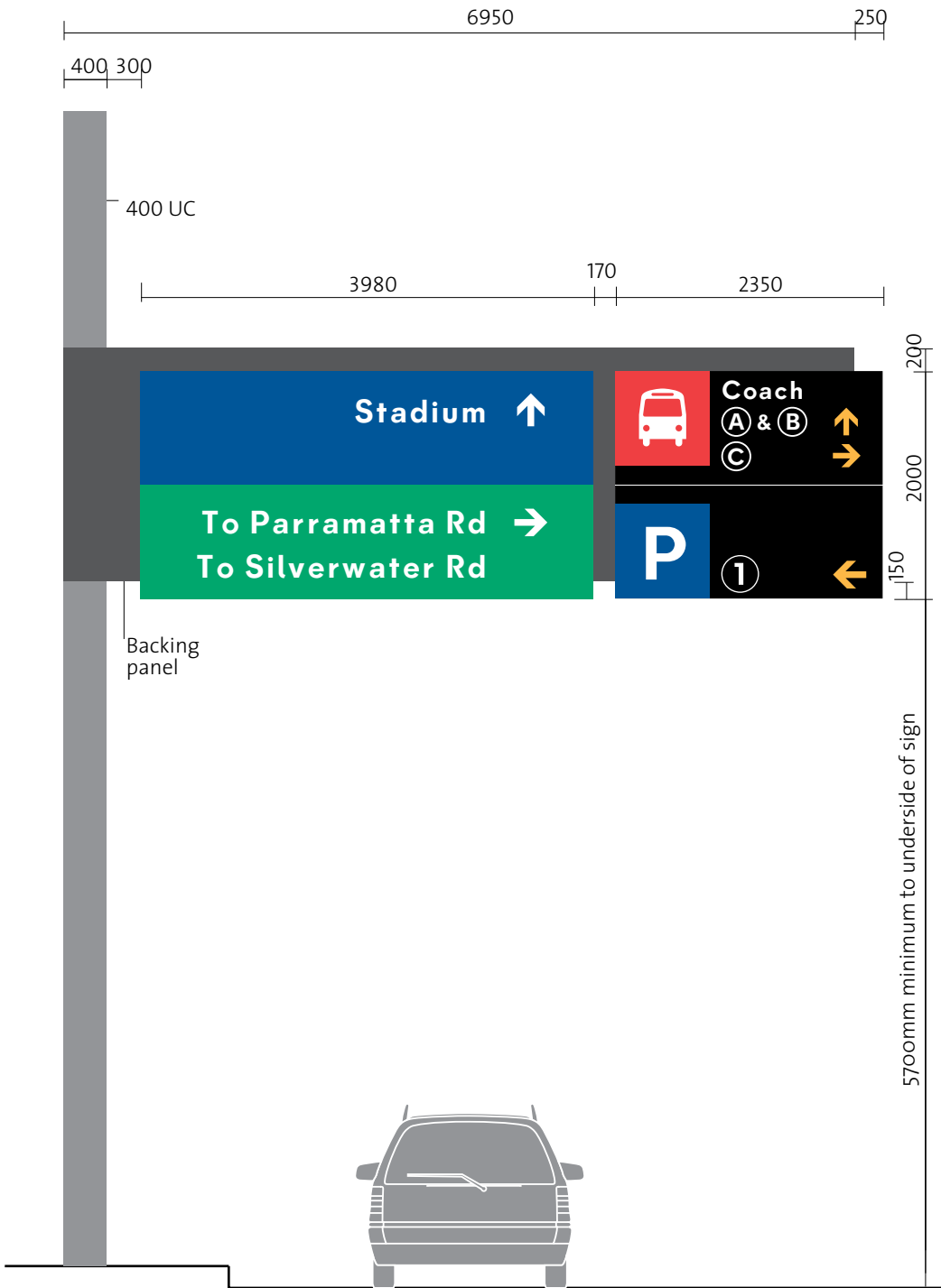

## Circulation Vehicular

### Function

Large-format sign used where important directions require prominent signage. Directs to car parks, exit points, next nearest venue and confirms straight on directions to events and venues. Is single sided only for direction of travel.

### Location

At Avenues and Link roads, not core areas. Placed 150mm approximately from a corner, directly adjacent to roads, opposite but offset 10 metres from lightpoles on the left hand side of the road with the flow of traffic. Speed of traffic to inform location. Placement is on the road edge within RTA regulations.

### Format

As per graphic representation shown.

### Text Heights

Venue text: 200mm

Parking numerals: 192mm

Coach text: 160mm

Coach letters: 140mm

### Specific Details

Arrows	S5
Pictograms	S3,S7
Colours	S2
Materials and finishes	S6
Slats	S13

### Principle

Large format sign used where important directions require prominent signage.

### Location

On approaches to major intersections.

REFER TO DETAILS APPENDICES A AND B

## Circulation Secondary Pedestrian

### Function

Large-format sign used where important directions require prominent signage. Provides major pedestrian directional information.

May also be single sided.

May have detailed map located on steel blade.

### Location

At appropriate direction points throughout all areas of the site where space permits and more specifically in central core areas. Located preferably away from the road edges, however on pedestrian routes.

### Format

As per graphic representation shown.

### Text Height

Directional: 100mm

### Specific Details

Arrows	S5
Pictograms	S3,S7
Colours	S2
Materials and finishes	S6
Slats	S9

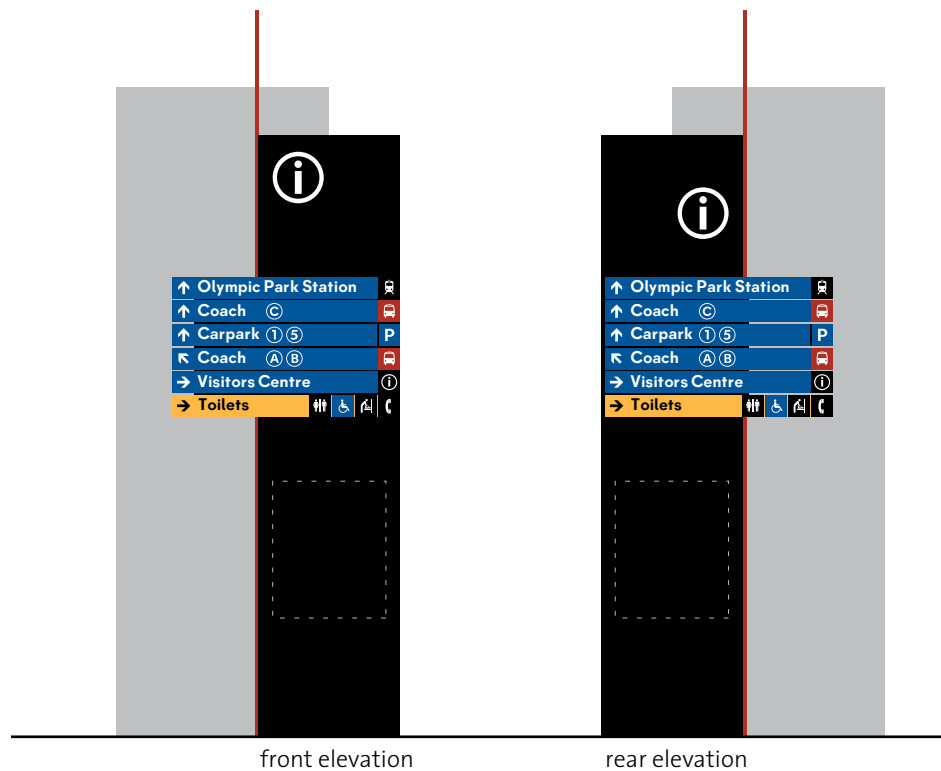
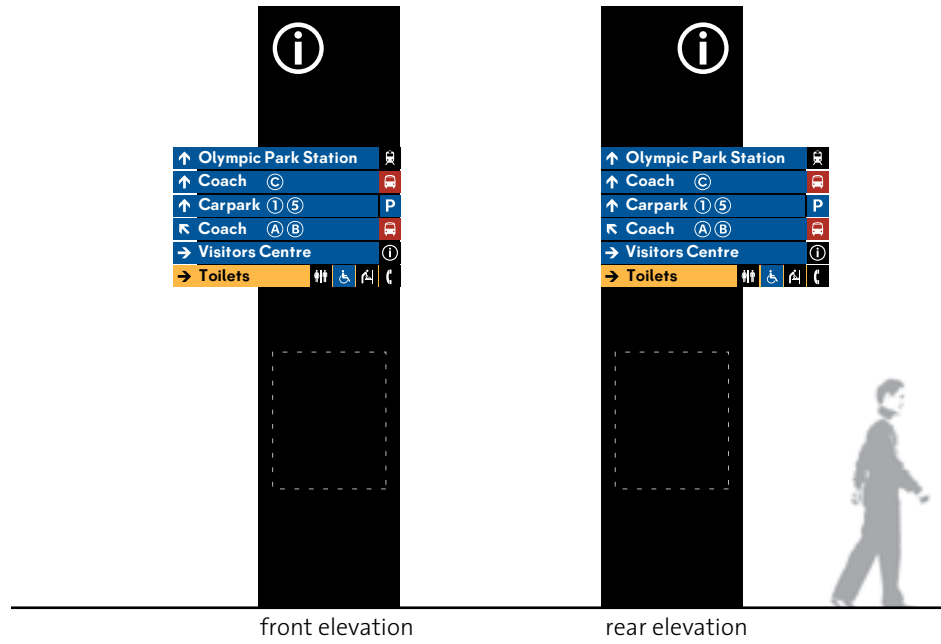

REFER TO DETAILS APPENDICES A AND B

S23

### Location

As required.

### Principle

Large format sign used where important directions require prominent signage.



## Circulation Secondary Pedestrian (Freestanding)

### Function

Small-format sign used where important directions required, however space or location does not require large format.

### Location

At appropriate direction points. Not next to road edges. Where possible mainly use in peripheral areas and tight spaces to reinforce circulation information given by larger signs.

May have detailed map located on steel blade.

### Format

As per graphic representation shown.

### Text Height

Directional: 100mm

### Specific Details

Arrows	S5
Pictograms	S3,S7
Colours	S2
Materials and finishes	S6
Slats	S9

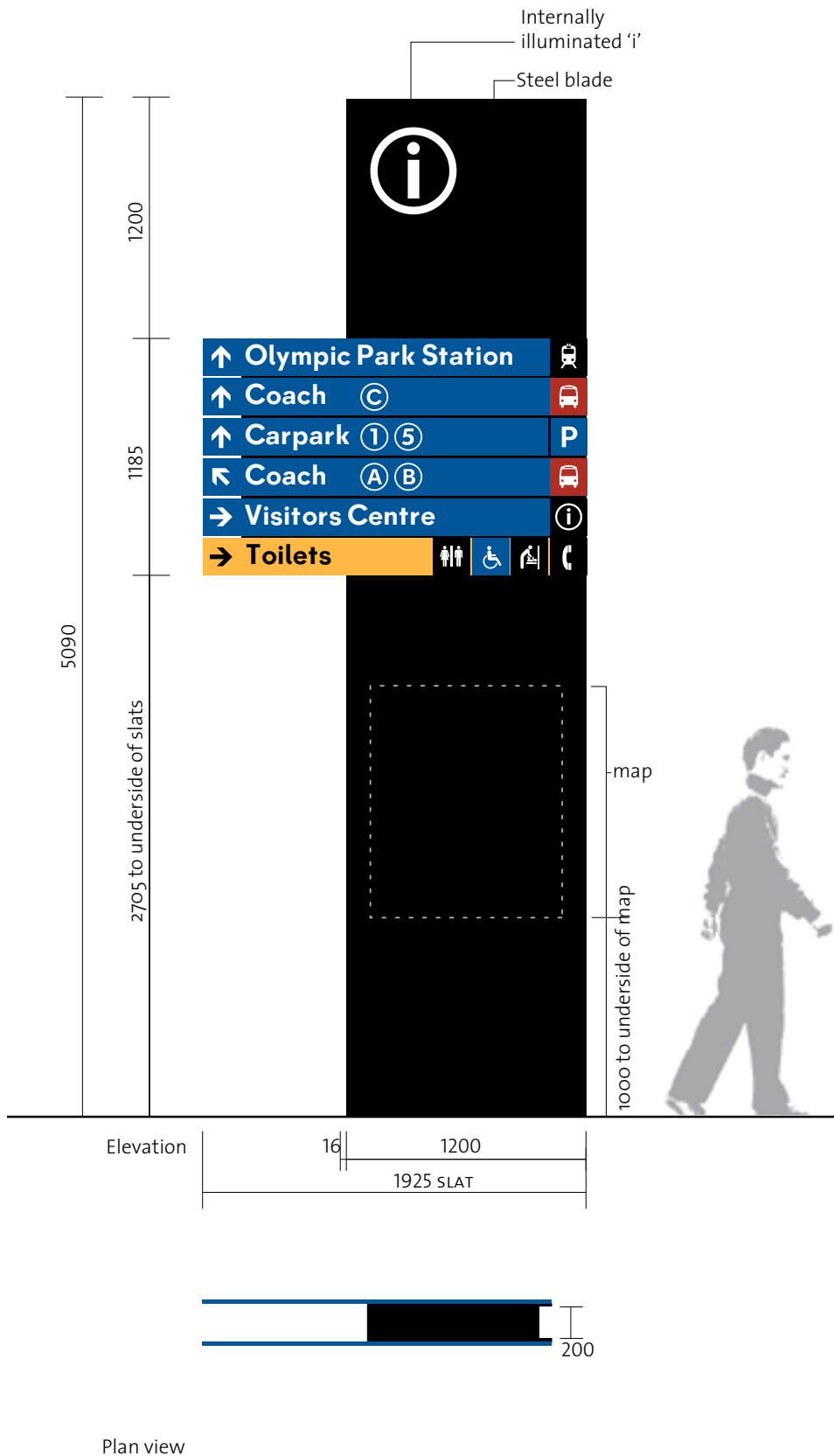

### Principle

Small format sign used where important directions are required.

### Location

As required.

REFER TO DETAILS APPENDICES A AND B

## Circulation Secondary Pedestrian

### Function

Large-format sign used where important directions require prominent signage. Provides major pedestrian directional information.

May also be single sided.

May have detailed map located on steel blade.

### Location

At appropriate direction points throughout all areas of the site where space permits and more specifically in central core areas. Located preferably away from the road edges, however on pedestrian routes.

### Format

As per graphic representation shown.

### Text Height

Directional: 100mm

### Specific Details

Arrows	S5
Pictograms	S3,S7
Colours	S2
Materials and finishes	S6
Slats	S9

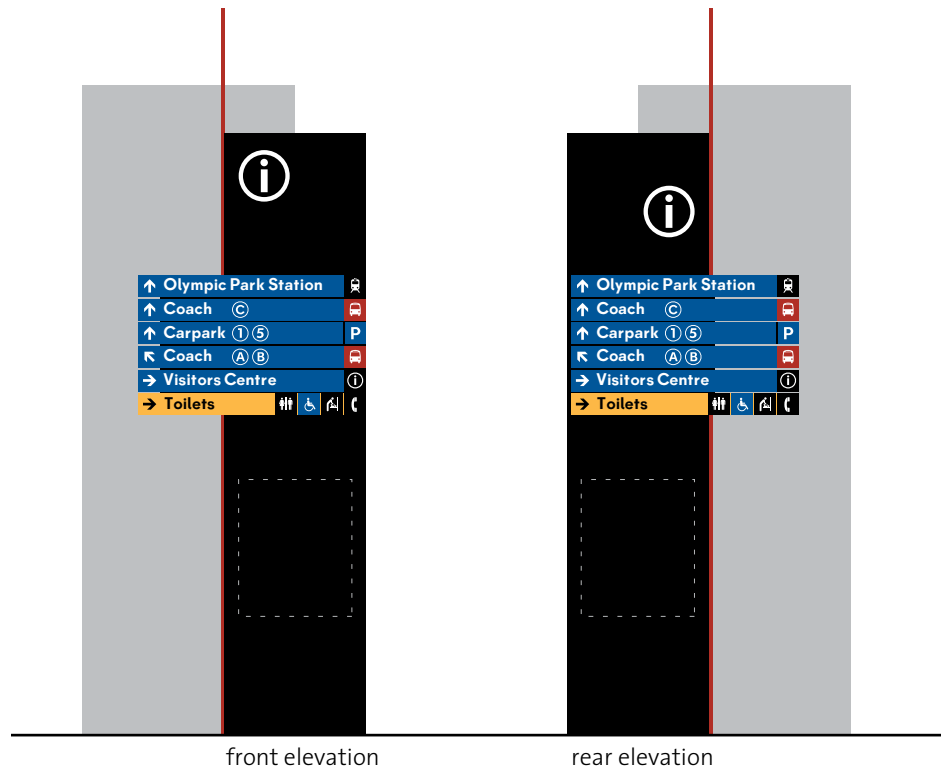
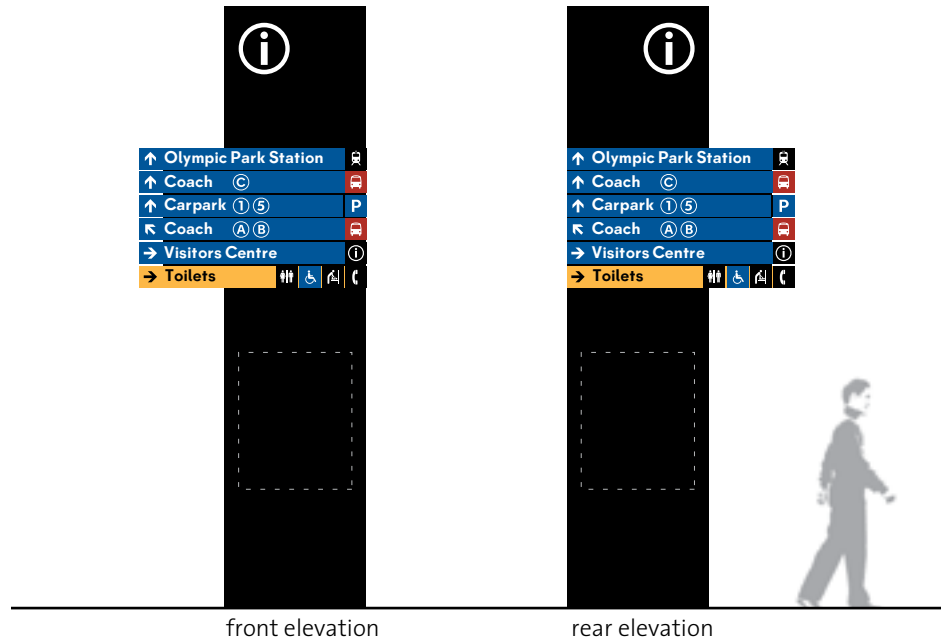

REFER TO DETAILS APPENDICES A AND B

# S23+S25

### Location

As required.

### Principle

Small format sign used where important directions are required.

## Circulation Finger Sign (Vehicular)

Page 1 of 2

### Function

Directional information in confined spaces and fringe areas.

### Location

Attached to light posts and poles especially where multi circulation decision points are required and space is limited. These sign types are to support and compliment the information on the S23 types and not replace them.

### Format

As per graphic representation shown.

### Text Height

Directional: 80mm

### Specific Details

Arrows	S5
Pictograms	S3,S7
Colours	S2
Materials and finishes	S6
Slats	S10
Slat layout and configuration	S16

Where signs occur at 180 degrees to each other they are to be positioned on the same plane.

Where signs occur at 90 degrees to each other they are to be stacked.

The upper stacked signs are to be set 50mm above the highest edge of lower sign panel blades as indicated.

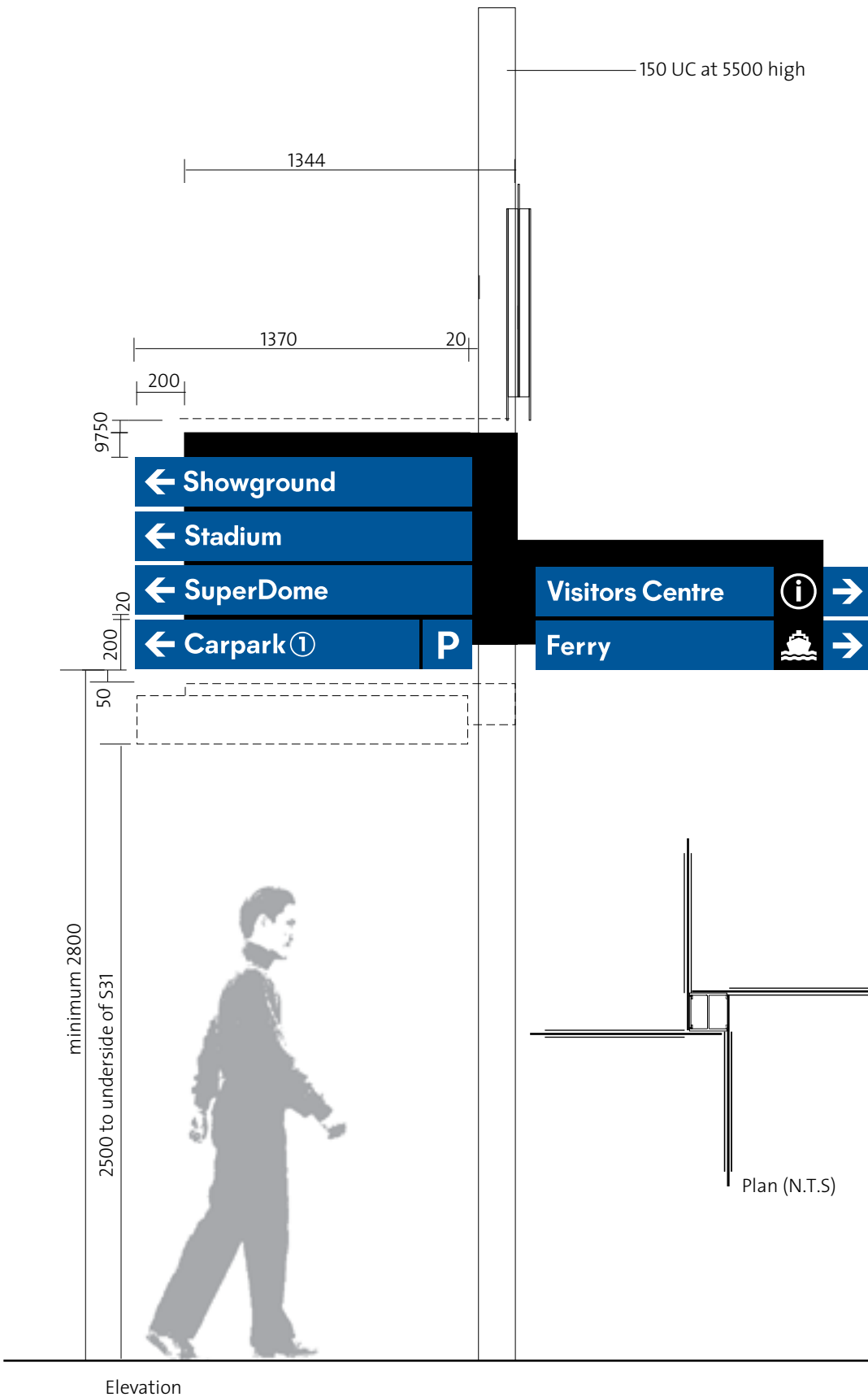

Elevation

### Principle

Street sign for all intersections.

### Location

At all intersections as per AS1742.5.

REFER TO DETAILS APPENDICES A AND B

# S26

# Circulation Finger Sign (Vehicular)

Page 2 of 2

## Function

Directional information in confined spaces and fringe areas.

## Location

Attached to light posts and poles especially where multi circulation decision points are required and space is limited. These sign types are to support and compliment the information on the S23 types and not replace them.

## Format

As per graphic representation shown.

## Text Height

Directional: 80mm

## Specific Details

Arrows	S5
Pictograms	S3,S7
Colours	S2
Materials and finishes	S6
Slats	S10
Slat layout and configuration	S16

Where signs occur at 180 degrees to each other they are to be positioned on the same plane.

Where signs occur at 90 degrees to each other they are to be stacked.

The upper stacked signs are to be set 50mm above the highest edge of lower sign panel blades as indicated.

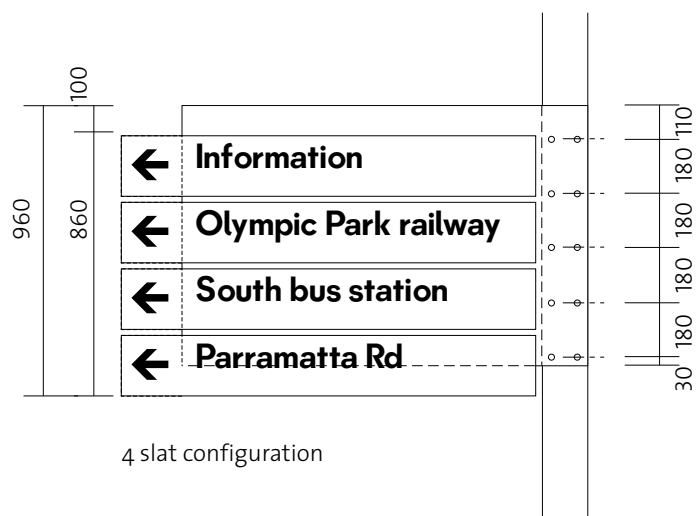
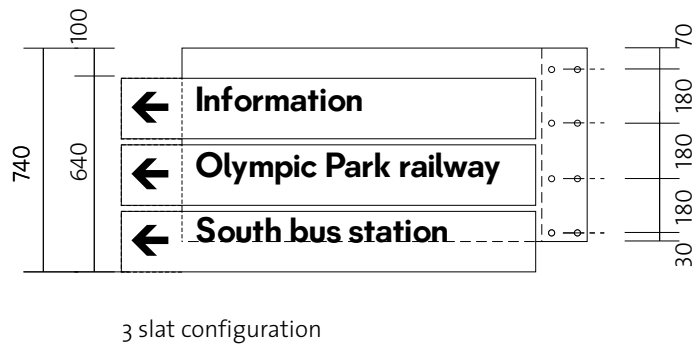
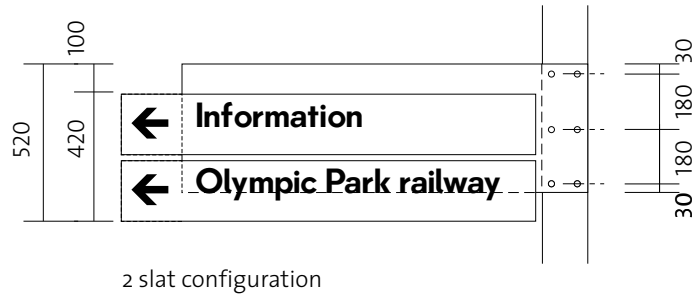
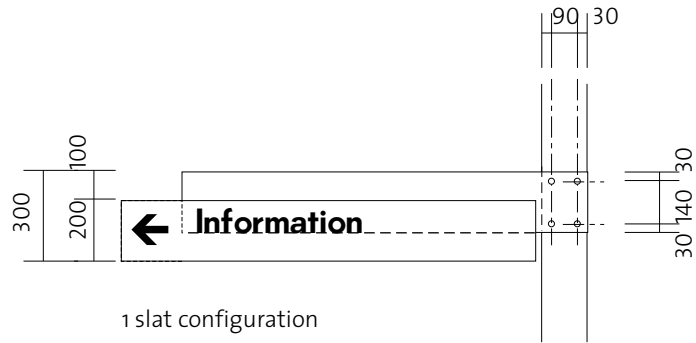

S26 Vehicular finger signs: slat layout options

REFER TO DETAILS APPENDICES A AND B

### Location

At all intersections as per AS1742.5.

### Principle

Street sign for all intersections.

# S26

## Circulation Finger Sign (Pedestrian)

Page 1 of 2

### Function

Directional information in confined spaces and fringe areas.

### Location

Attached to light posts and poles especially where multi circulation decision points are required and space is limited, for example, the showgrounds. These sign types are to support and compliment the information on the S23 types and not replace them.

### Format

As per graphic representation shown.

### Text Height

Directional: 60mm

### Specific Details

Arrows	S5
Pictograms	S3,S7
Colours	S2
Materials and finishes	S6
Slats	S11
Slat layout and configuration	S16

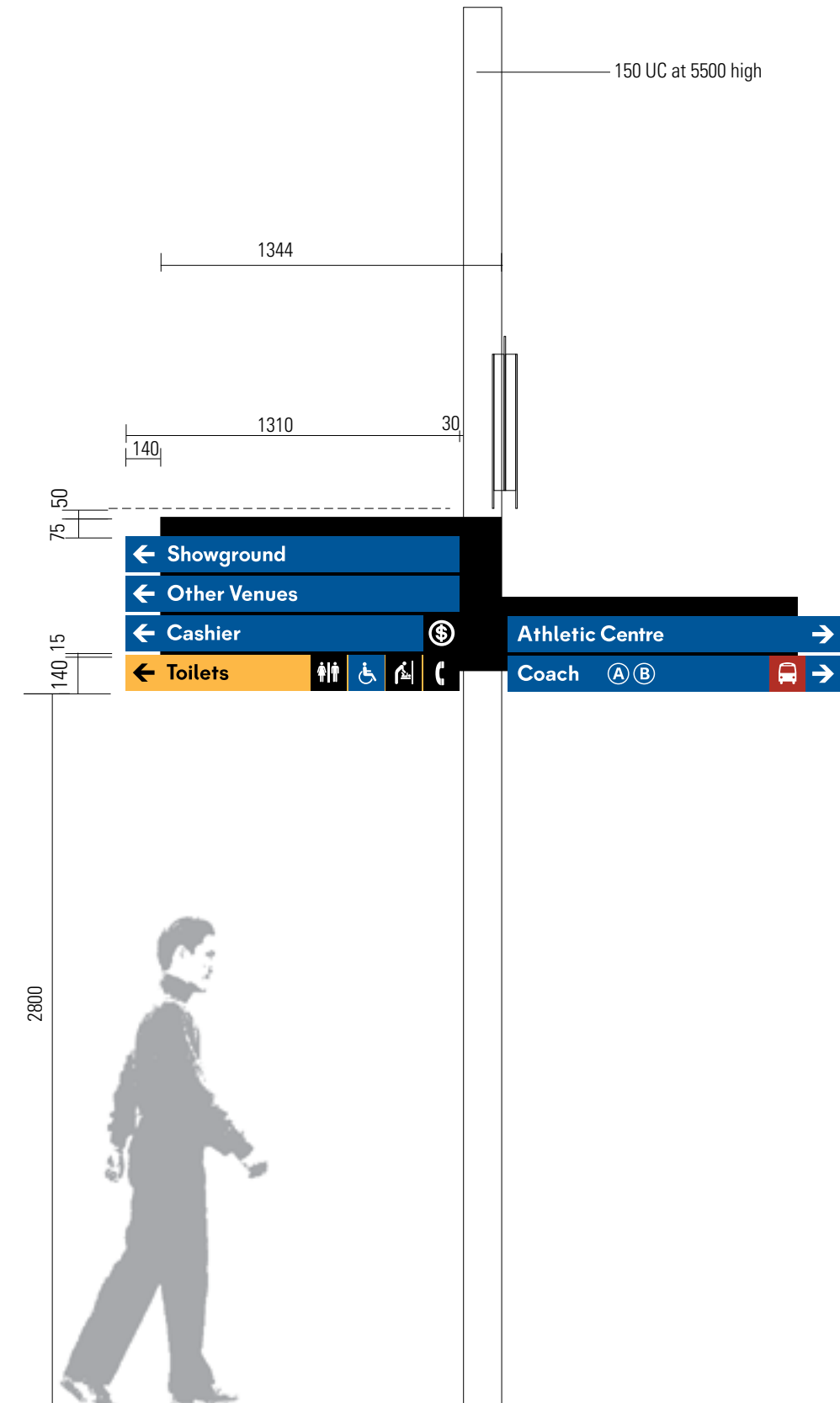

Elevation

### Principle

Directional information where larger signs are inappropriate in peripheral areas.

### Location

Attached to light poles as required.

REFER TO DETAILS APPENDICES A AND B

**S27**

## Circulation Finger Sign (Pedestrian)

Page 2 of 2

### Function

Directional information in confined spaces and fringe areas.

### Location

Attached to light posts and poles especially where multi circulation decision points are required and space is limited, for example, the showgrounds. These sign types are to support and compliment the information on the S23 types and not replace them.

### Format

As per graphic representation shown.

### Text Height

Directional: 60mm

### Specific Details

Arrows	S5
Pictograms	S3,S7
Colours	S2
Materials and finishes	S6
Slats	S11
Slat layout and configuration	S16

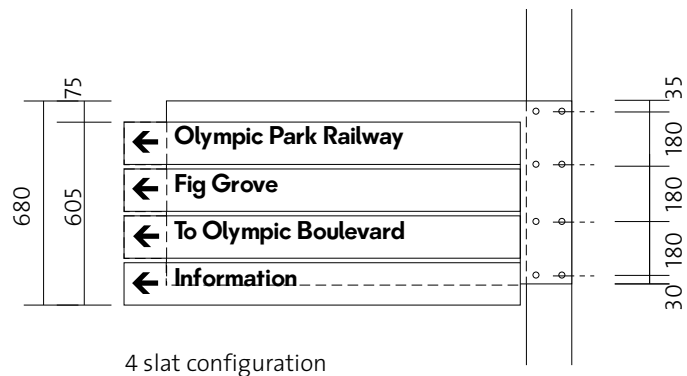
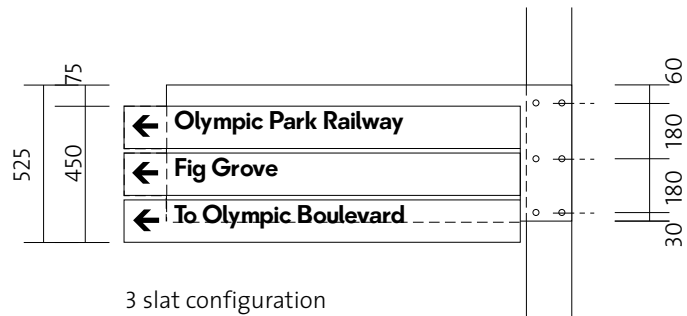
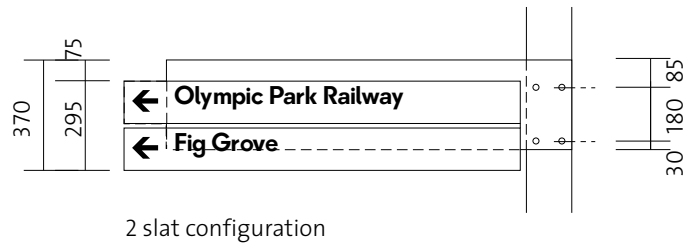
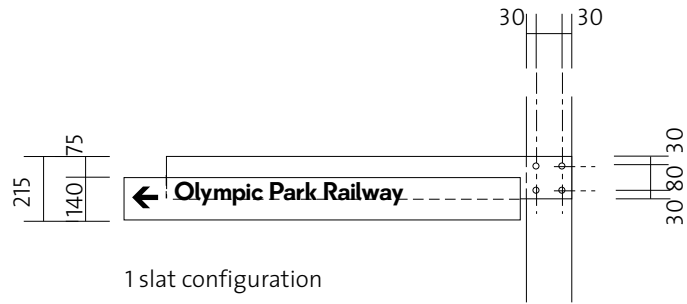

S27 Vehicular finger signs: slat layout options

REFER TO DETAILS APPENDICES A AND B

# S27

### Location

Attached to light poles as required.

### Principle

Directional information where larger signs are inappropriate in peripheral areas.

## Circulation Vehicular Bus Stop (Double Sided Blade)

Page 1 of 2

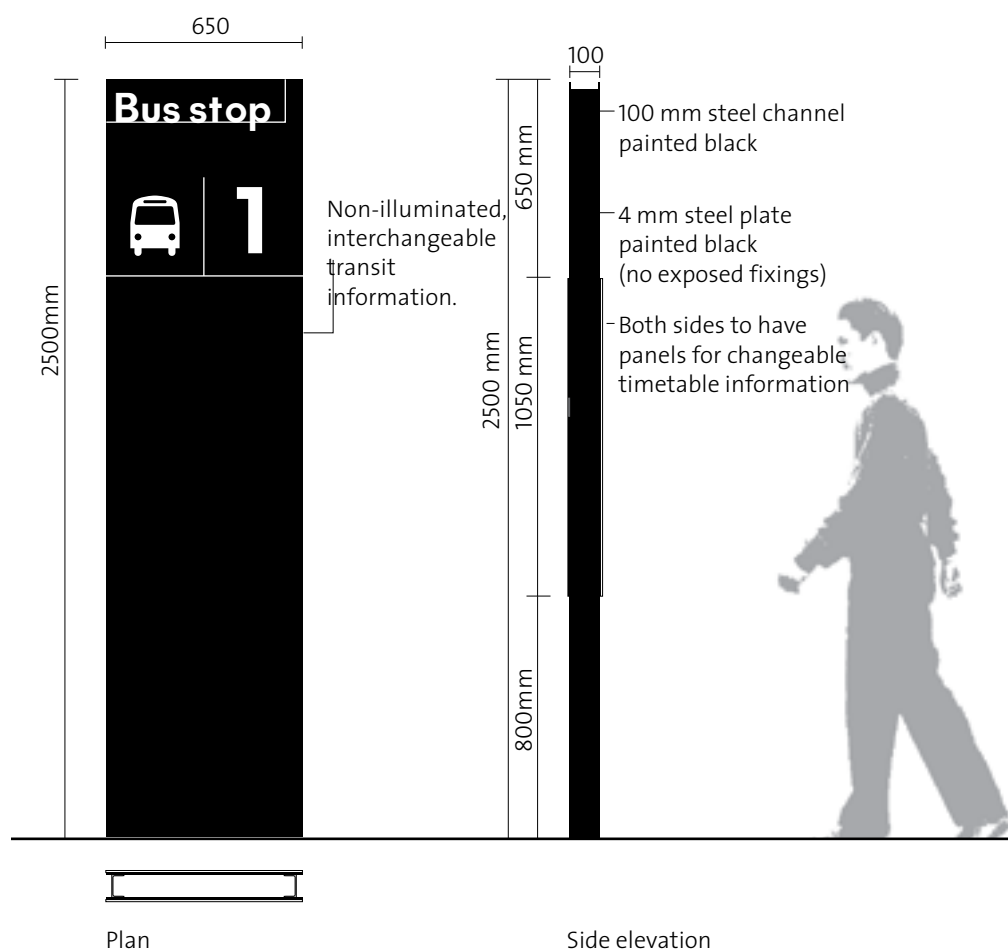

### Function

To identify transit pickup and setdown points, eg bus stops, taxi ranks, and to identify loading docks.

### Location

At appropriate transit points near poles or blade elements.

### Format

As per graphic representation shown.

### Text Height

Horizontal text: 95mm

### Specific Details

Arrows	S5
Pictograms	S3,S7
Colours	S2
Materials and finishes	S6

### Principle

Identification of bus stops.

### Location

Bus stops.

REFER TO DETAILS APPENDICES A AND B

# S30

## Circulation Vehicular Bus Stop (Double Sided Blade)

Page 2 of 2

### Function

To identify transit pickup and setdown points, eg bus stops, taxi ranks, and to identify loading docks.

### Location

At appropriate transit points near poles or blade elements.

### Format

As per graphic representation shown.

### Text Height

Vertical text: 125mm

Horizontal text: 80mm

### Specific Details

Arrows	S5
Pictograms	S3,S7
Colours	S2
Materials and finishes	S6

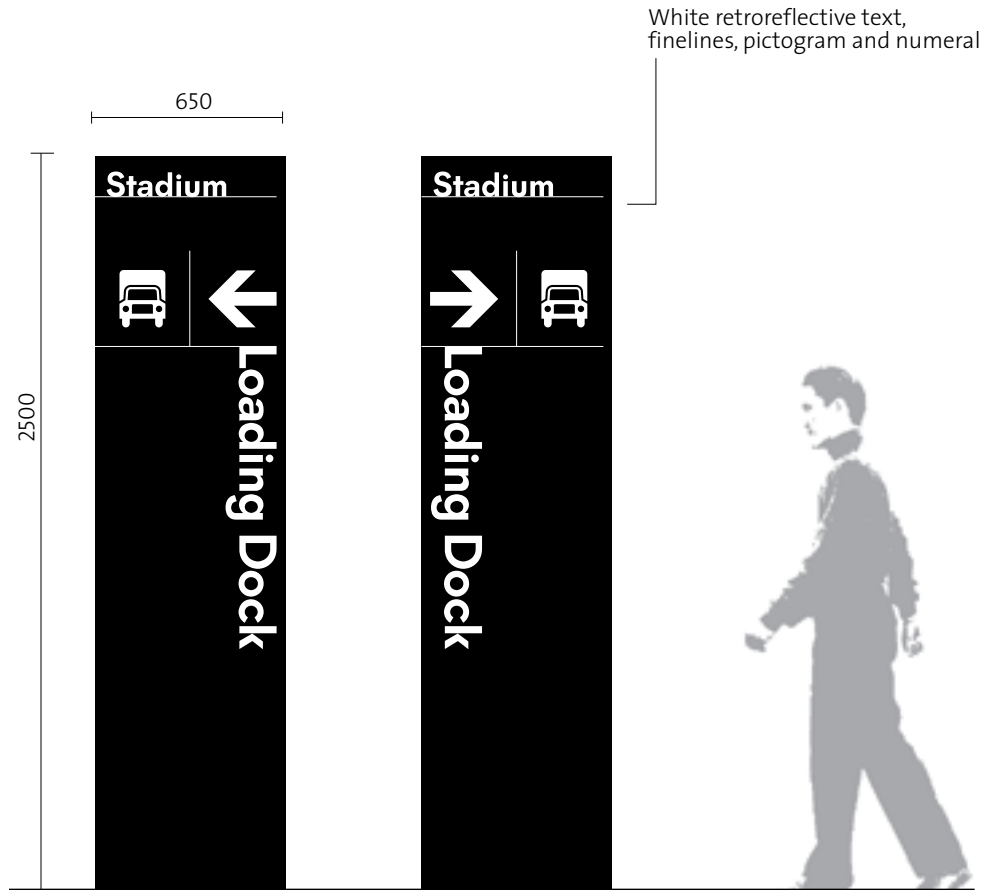

Other graphic options

REFER TO DETAILS APPENDICES A AND B

# S30

Location

Bus stops.

Principle

Identification of bus stops.



## Circulation Vehicular Street Name Sign

### Function

Street sign used at all intersections. May be used on minor avenue and street poles.

### Location

At all intersections as per AS 1742.5.

### Format

As per graphic representation shown.

### Text Height

First name: 40mm

Surname: 100mm

Abbreviation of street: 57mm

### Specific Details

Arrows S5

Pictograms S3,S7

Colours S2

Materials and finishes S6

For layout with S26 signs S13

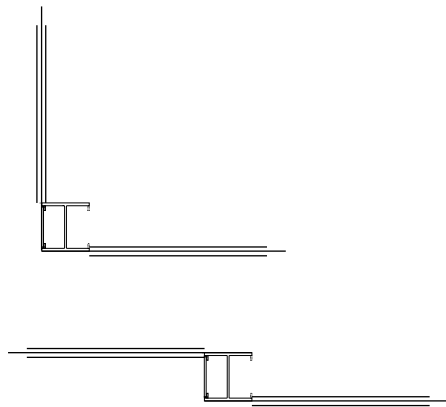

Examples of different configurations

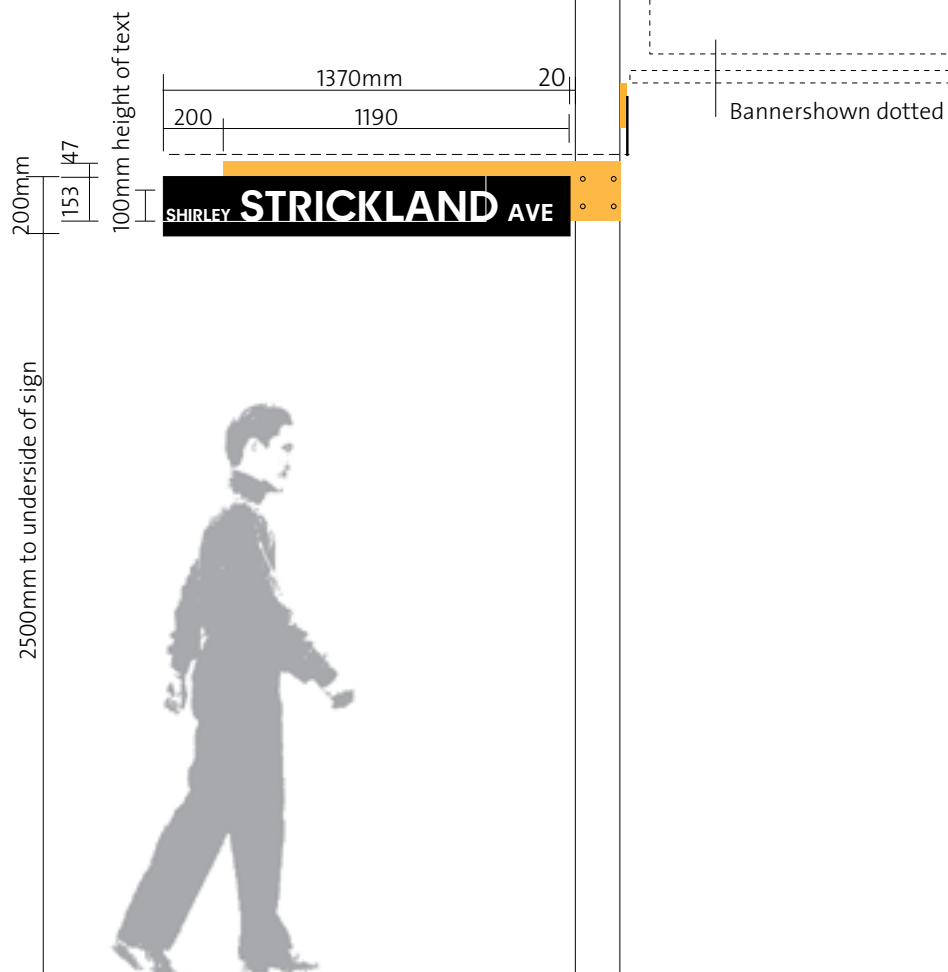

Elevation

### Principle

Identification of street names.

### Location

Urban core road intersections.

REFER TO DETAILS APPENDICES A AND B

## Circulation Vehicular Bus Stop

### Function

To identify transit pickup and setdown points, eg bus stops, taxi ranks, etc.

### Location

At appropriate transit points fixed to posts or blade elements.

### Format

As per graphic representation shown.

### Text Height

see page S14

### Specific Details

Arrows	S5
Pictograms	S3,S7
Colours	S2
Materials and finishes	S6
Slats	S14
For different bus operation graphic layout refer to page 2 of 2	S33

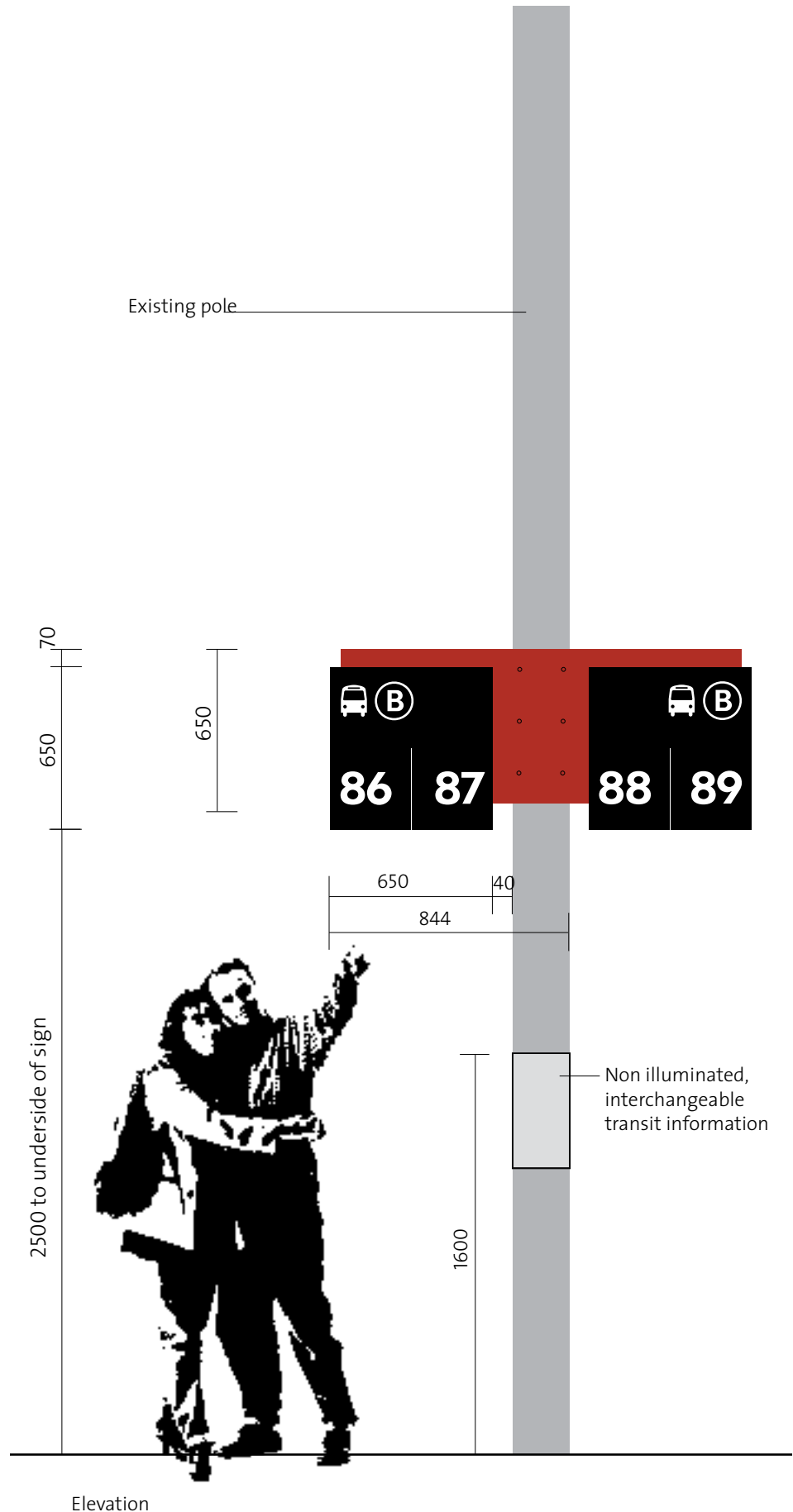

REFER TO DETAILS APPENDICES A AND B

S33

### Location

Minor bus stops.

### Principle

Identification of minor bus stops.

**Identification  
Regional Bus Stopstation  
(Temporary)**

Page 1 of 6

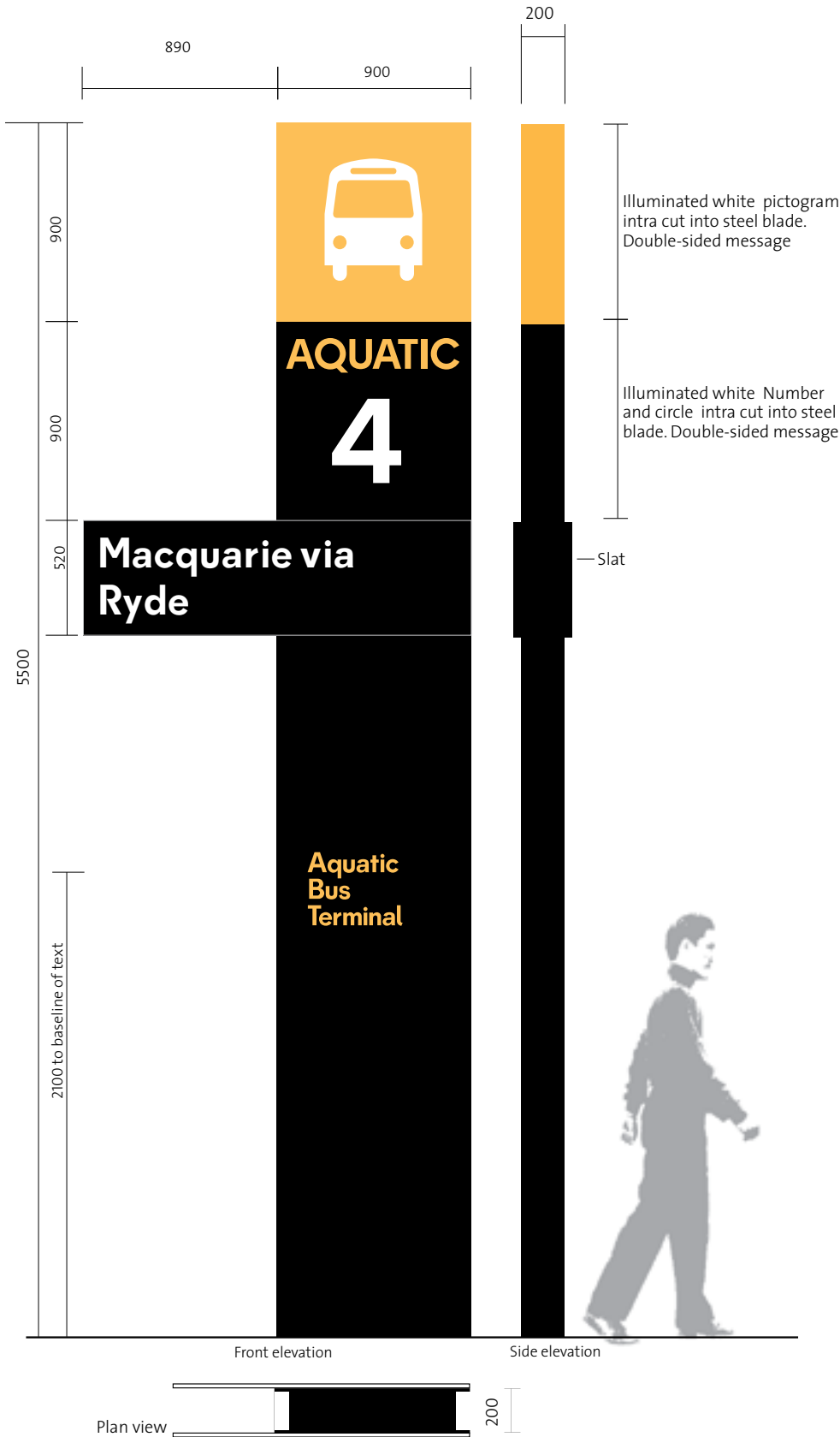

**Function**

To identify bus terminals along the Olympic Boulevard.

**Location**

At appropriate points to identify bus terminal entrances.

**Format**

As per graphic representation shown.

**Text Height**

'plaza': 135mm

Number: 400mm

Slat: 135mm

Lower text on blade: 90mm

**Specific Details**

Pictograms	S3,S7
Colours	S2
Materials and finishes	S6

**Principle**

To identify regional bus stops and locate entrance points.

**Location**

Regional bus stops.

REFER TO DETAILS APPENDICES A AND B

**S36BD**

# Identification Regional Bus Stopstation (Permanent)

Page 2 of 6

### Function

To identify bus terminals along the Olympic Boulevard.

### Location

At appropriate points to identify bus terminal entrances.

### Format

As per graphic representation shown.

### Text Height

'aquatic': 135mm

Letter: 400mm

Slat: 135mm

Lower text on blade: 90mm

### Specific Details

Pictograms S3,S7

Colours S2

Materials and finishes S6

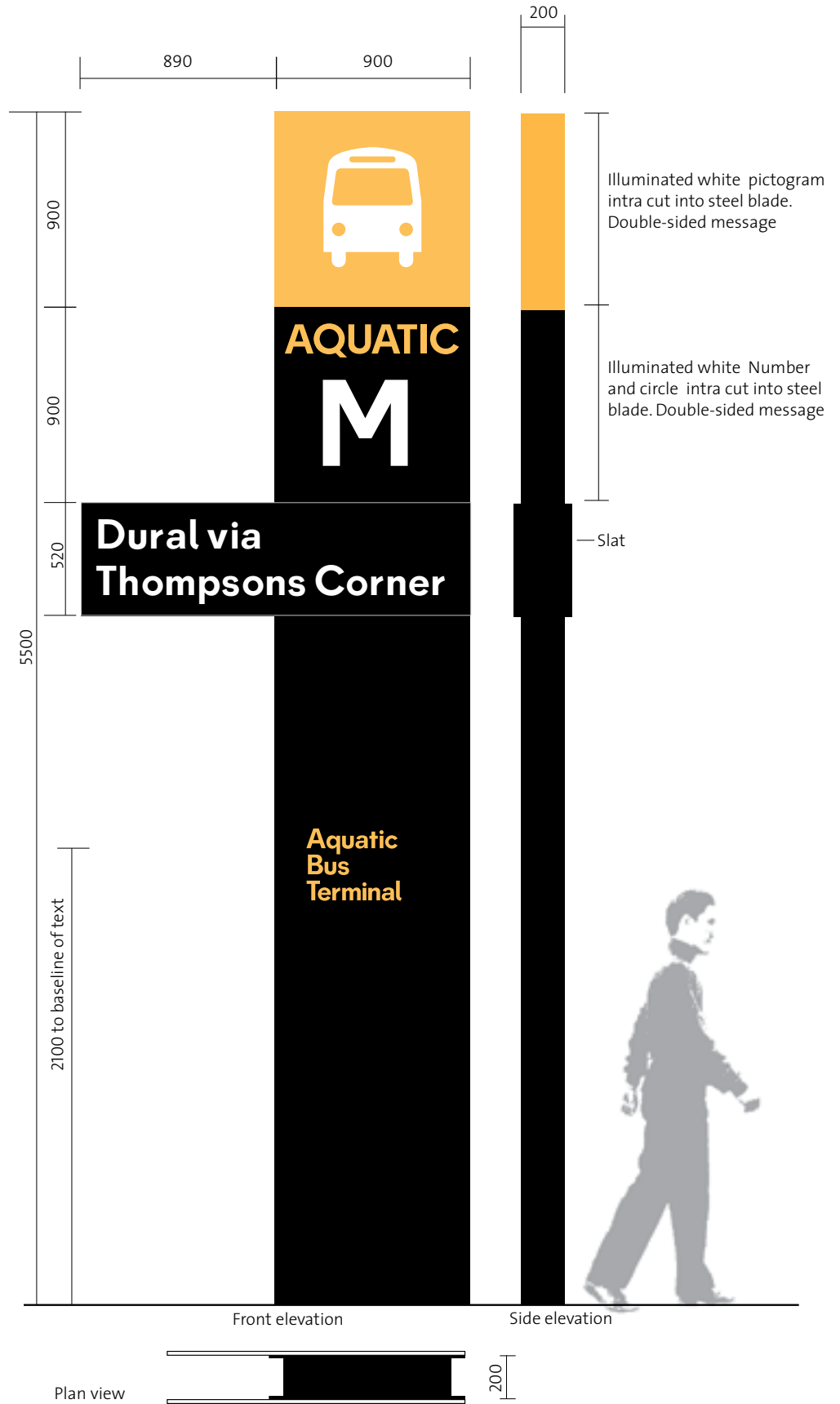

REFER TO DETAILS APPENDICES A AND B

# S36BD

### Location

Regional bus stops.

### Principle

To identify regional bus stops and locate entrance points.

**Luminaire Type a**

**Identification  
Regional Bus Stopstation**

Page 3 of 6

**Function**

To identify bus terminals along the Olympic Boulevard.

**Location**

At appropriate points to identify bus terminal entrances.

**Format**

As per graphic representation shown.

**Text Height**

'aquatic': 135mm

Letter: 400mm

Slat: 135mm

Lower text on blade: 90mm

**Specific Details**

Pictograms S3,S7

Colours S2

Materials and finishes S6

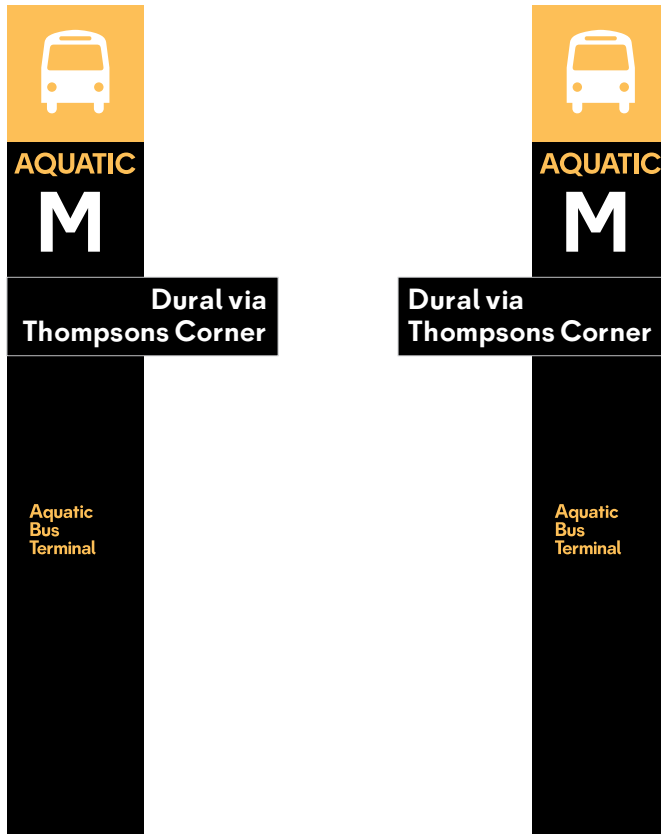

S36bd Regional Bus Stop: permanent

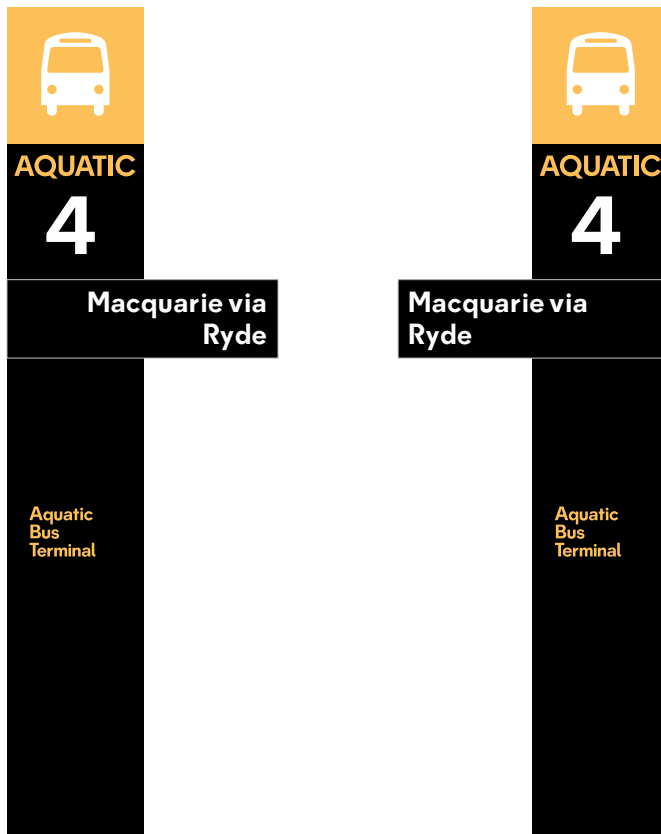

S36bd Regional Bus Stop: temporary overlay

**Principle**

To identify regional bus stops and locate entrance points.

**Location**

Regional bus stops.

REFER TO DETAILS APPENDICES A AND B

**S36BD**

## Identification Coach Station

Page 4 of 6

### Function

To identify coach stations approach roads and to locate entrance points.

### Location

At appropriate points to identify coach station entrances.

### Format

As per graphic representation shown.

### Specific Details

Pictograms	S3,S7
Colours	S2
Materials and finishes	S6

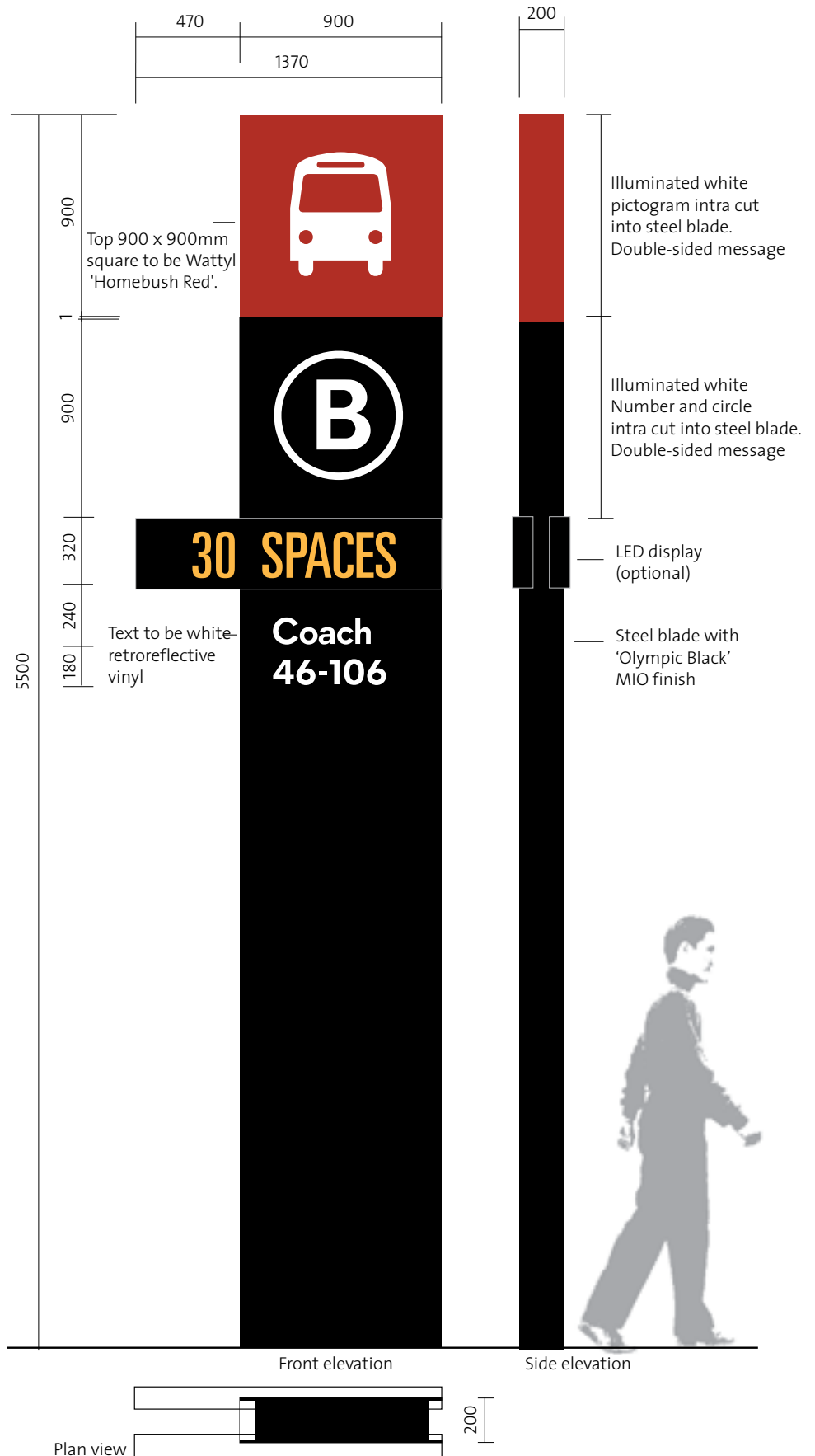

REFER TO DETAILS APPENDICES A AND B

# S36CD

### Location

Coach stations.

### Principle

To identify coach station.

**Identification  
Primary Car Park**

Page 6 of 6

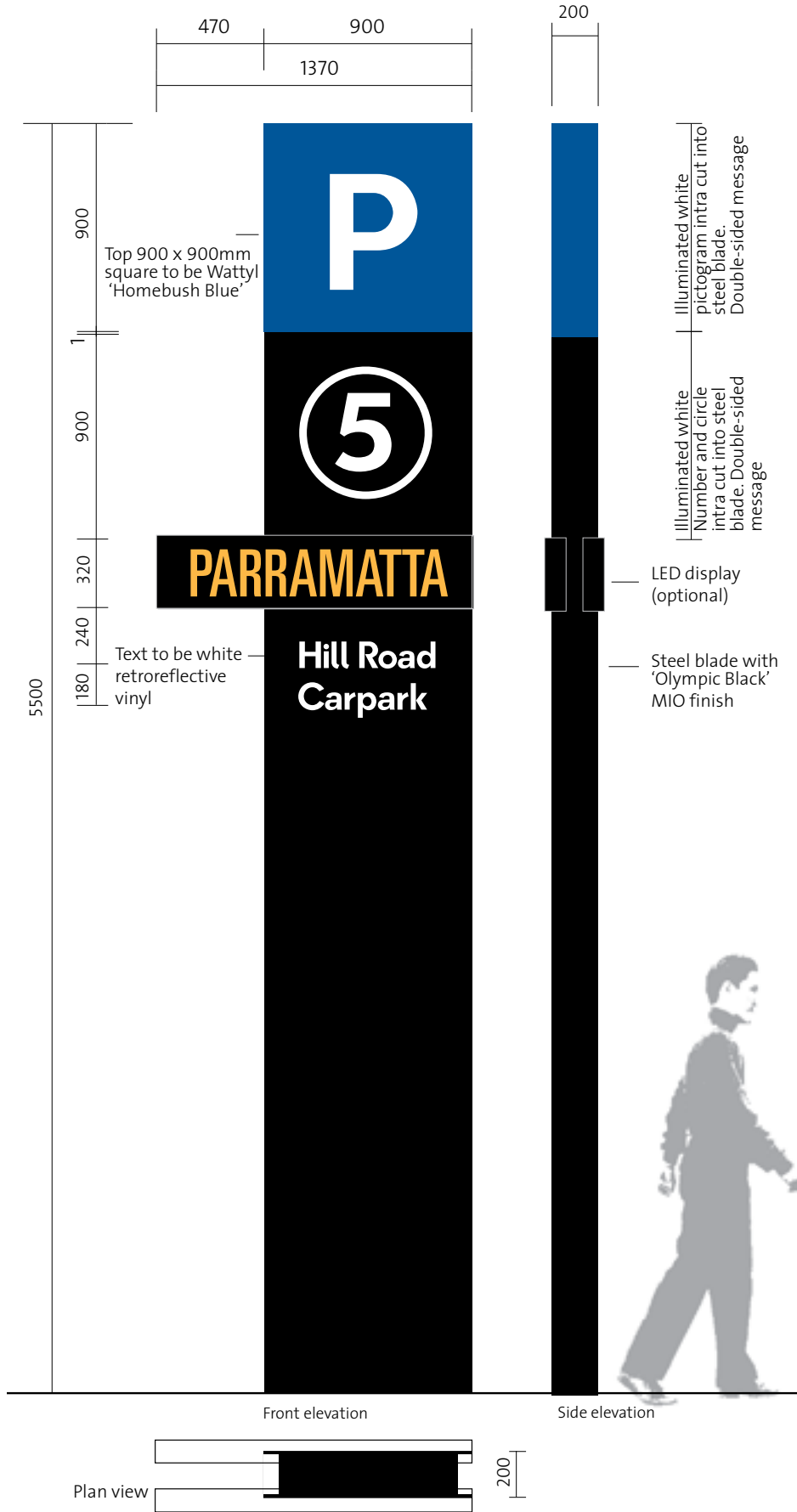

**Function**

To identify car parks on approach roads and to locate entrance points.

**Location**

At appropriate points to car park entrances.

**Format**

As per graphic representation shown.

**Specific Details**

Pictograms	S3,S7
Colours	S2
Materials and finishes	S6

**Principle**

To identify carparks.

**Location**

On approach roads and entry points to carparks.

REFER TO DETAILS APPENDICES A AND B

**S36VD**

## Identification Primary Venue Marker

Page 1 of 3

### Function

To identify large scale venues on approach roads and to locate entrance points.

### Location

At appropriate points to venue entrances.

### Format

As per graphic representation shown.

### Text Height

Vertical text: 305mm

Horizontal text: 170mm

### Specific Details

Pictograms S3,S7

Colours S2

Materials and finishes S6

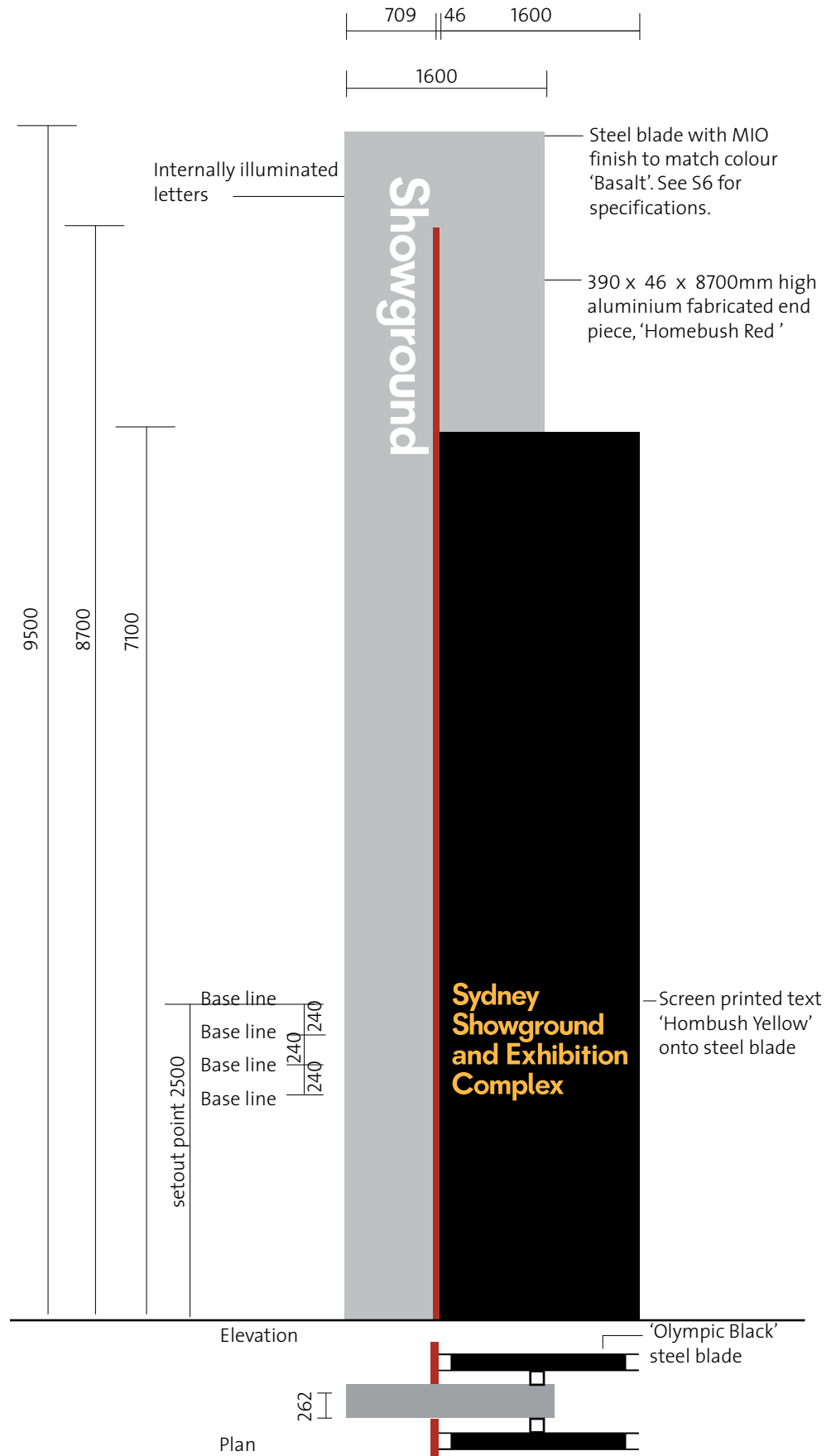

REFER TO DETAILS APPENDICES A AND B

# S37

### Location

At major venues.

### Principle

Identify major venues.



**Function**

To identify small scale venues on approach roads and to locate entrance points.

**Location**

At appropriate points to venue entrances.

**Format**

As per graphic representation shown.

**Text Height**

Vertical text: 305mm

Horizontal text: 170mm

**Specific Details**

Pictograms	S3,S7
Colours	S2
Materials and finishes	S6



S37A Secondary venue marker: vertical text to be closest to adjacent laneway which approaches the sign

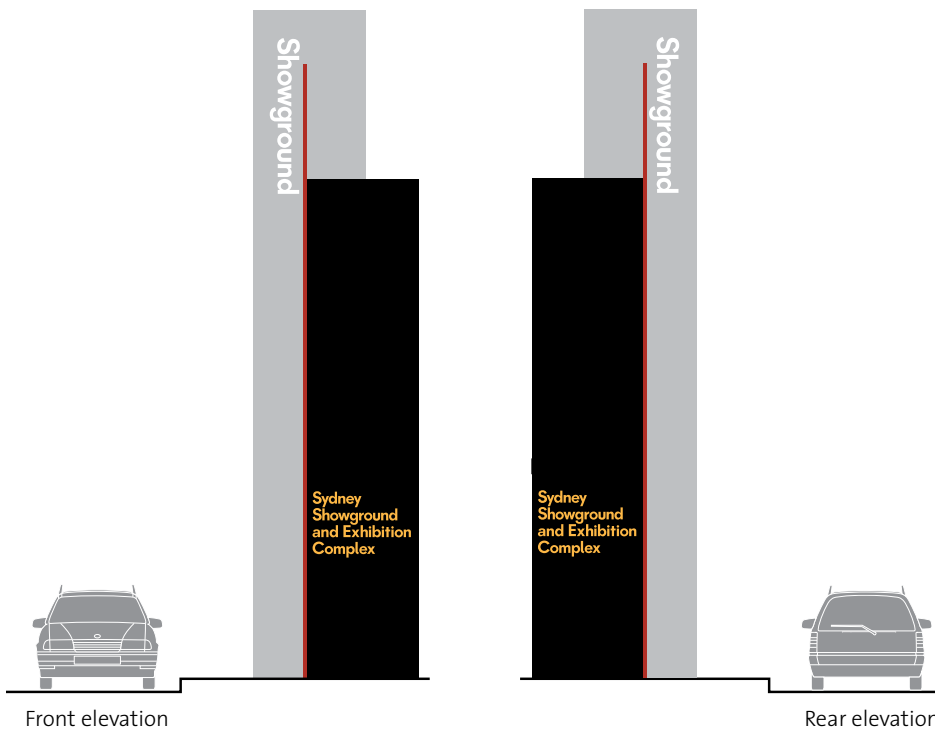

S37 Primary venue marker: vertical text to be closest to the road

**Principle**

Identify major venues.

**Location**

At major venues.

REFER TO DETAILS APPENDICES A AND B

**Identification  
Primary Venue Marker**

Page 3 of 3

**Function**

To identify venues on approach roads and to locate entrance points.

**Location**

At appropriate points to identify venue entrances.

**Format**

As per graphic representation shown.

**Text Height**

Vertical text: 320mm

Horizontal text: 110mm

**Specific Details**

Pictograms S3,S7

Colours S2

Materials and finishes S6

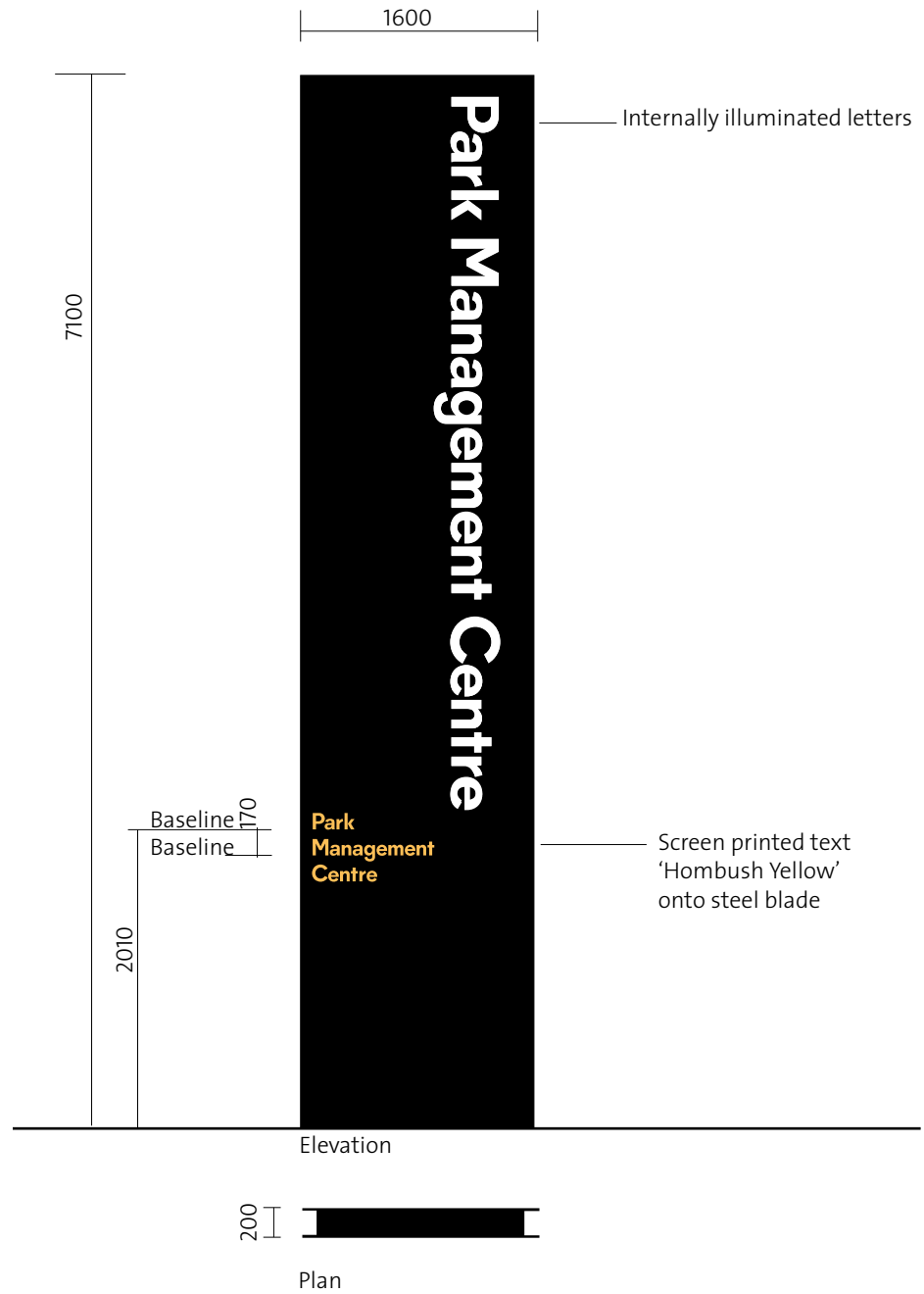

REFER TO DETAILS APPENDICES A AND B

**S37A**

Location	Principle
At major venues.	Identify major venues.

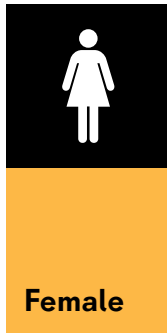
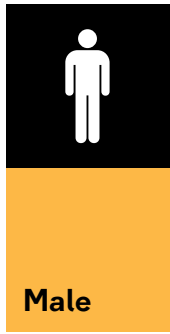

Black panel with white pictograms  
 'Homebush Yellow' panel with black text



'Homebush Blue' panel with white pictograms  
 'Homebush Yellow' panel



Pictograms and lettering to be screen printed  
 Text to be olympic 2000 38mm uppercase cap height

Typical setout next to door for single and double plate. Note: Single plate to be located 50mm from door frame.

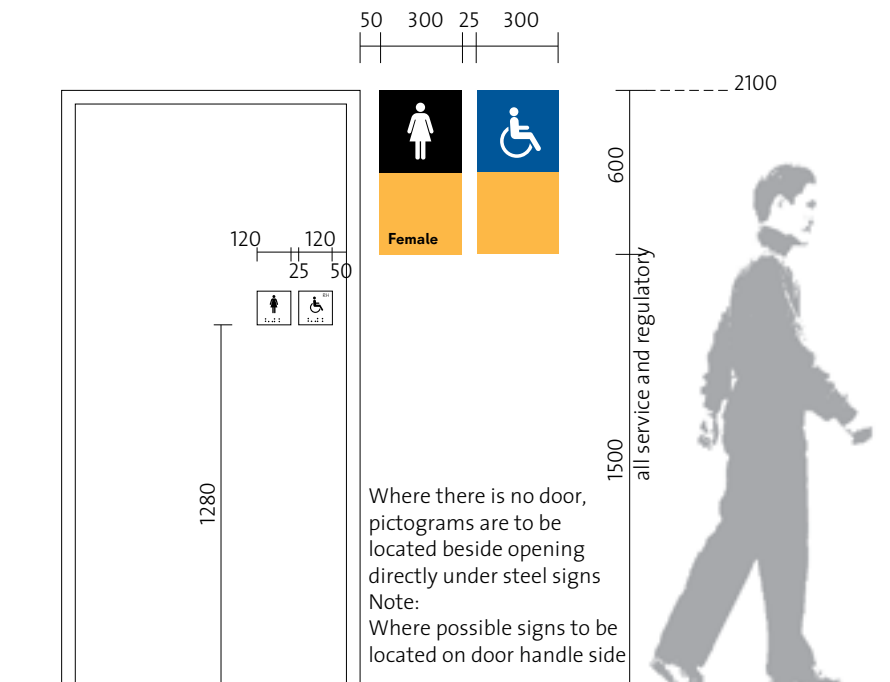

**Function**

Pictograms with sign panels are used as a marker to indicate entry points to toilet facilities.

**Location**

Located on walls, facilities, etc, where close reading of information is required.

**Format**

As per graphic representation shown.

**Specific Details**

Pictograms	S3,S7
Colours	S2
Materials and finishes	S6

**Principle**

Indicate entry points to service facilities.

**Location**

On walls, facilities, etc as required.

REFER TO DETAILS APPENDICES A AND B

**Services**

Page 2 of 2

**Function**

Pictograms with sign panels are used as a marker to indicate entry points to toilet facilities.

**Location**

Adjacent to toilet facilities.

**Format**

As per graphic representation shown.

**Specific Details**

Pictograms	S3,S7
Colours	S2
Materials and finishes	S6

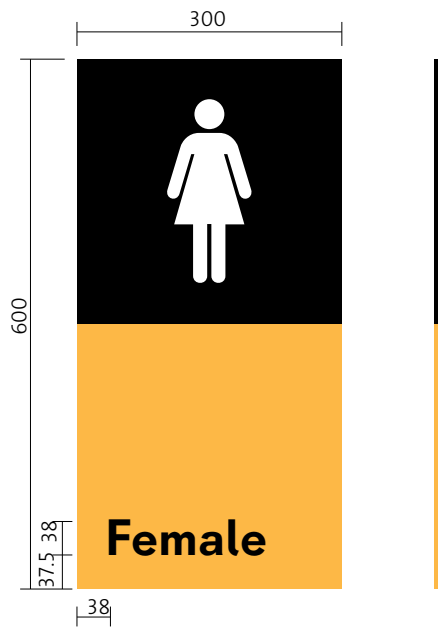

General note:

4mm steel plate  
spaced 6mm from  
wall surface

Pictograms and lettering  
to be screen printed  
Text to be olympic 2000  
38mm uppercase cap height

Metal wall signs

Side elevation

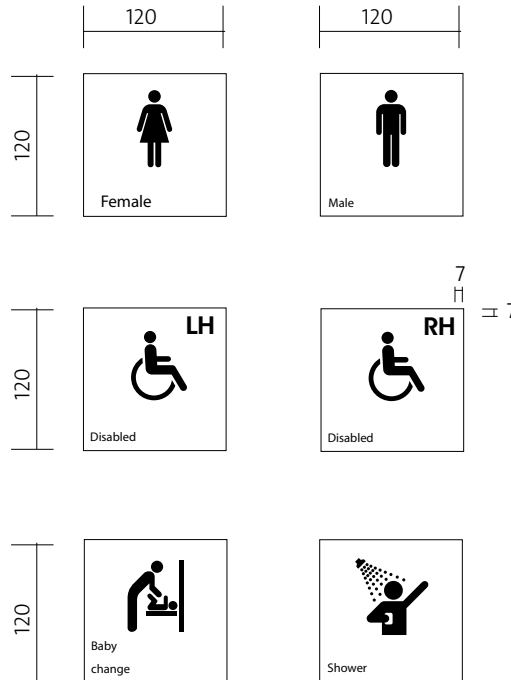

Text, pictograms, fine rules  
and braille to be 2mm raised  
acrylic tactile. Lettering to be  
Olympic 2000 15mm uppercase  
cap height

Base plate to be black  
Pictogram to be white  
Disabled baseplate  
to match 'Homebush Blue'

Tactile door signs

REFER TO DETAILS APPENDICES A AND B

**S40**

**Location**

On walls, facilities, etc as  
required.

**Principle**

Indicate entry points to service facilities.

## Regulatory

### Function

Strong visual pictograms and sign panels used to provide prohibitive warnings.

### Location

Located on walls, facilities, etc, where distance reading of information is required.

### Format

As per graphic representation shown.

### Specific Details

Pictograms	S3,S7
Colours	S2
Materials and finishes	S6



27,5  
Front elevation

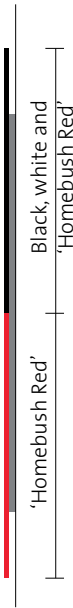

Side elevation

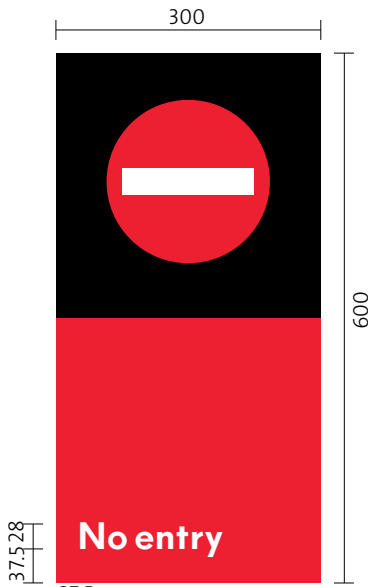

27,5  
Front elevation

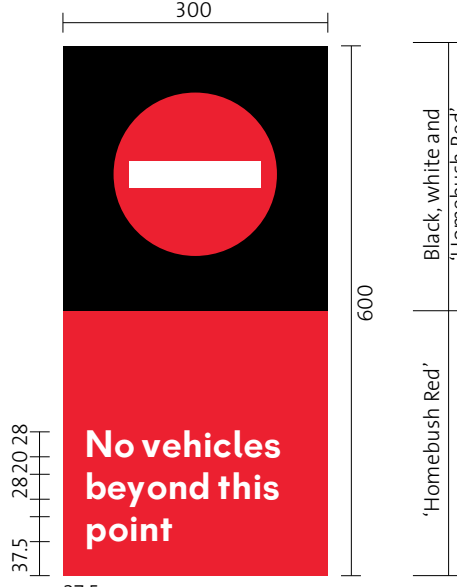

27,5  
Front elevation

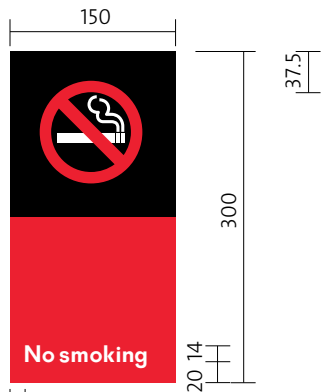

14  
Small regulatory/Front elevation

### General note:

4mm steel plate spaced 6mm from wall surface  
Pictograms and white text shall be screenprinted.

### Principle

To provide prohibitive warnings.

### Location

On walls, facilities, etc as required.

REFER TO DETAILS APPENDICES A AND B

## Regulatory Vehicular Stop Sign

### Function

To identify road traffic regulation.

### Location

At appropriate intersections.

### Format

As per graphic representation shown.

### Specific Details

Arrows	S5
Pictograms	S3,S7
Colours	S2
Materials and finishes	S6



REFER TO DETAILS APPENDICES A AND B

S43

### Location

As required.

### Principle

Regulatory sign for vehicle control.

**Opening Plaque  
Function**

Plaque to acknowledge the opening of a building.

**Location**

Fixed to existing building face where appropriate.

**Format**

As per graphic representation shown.

**Specific Details**

Typeface	S1
Materials and finishes	S6

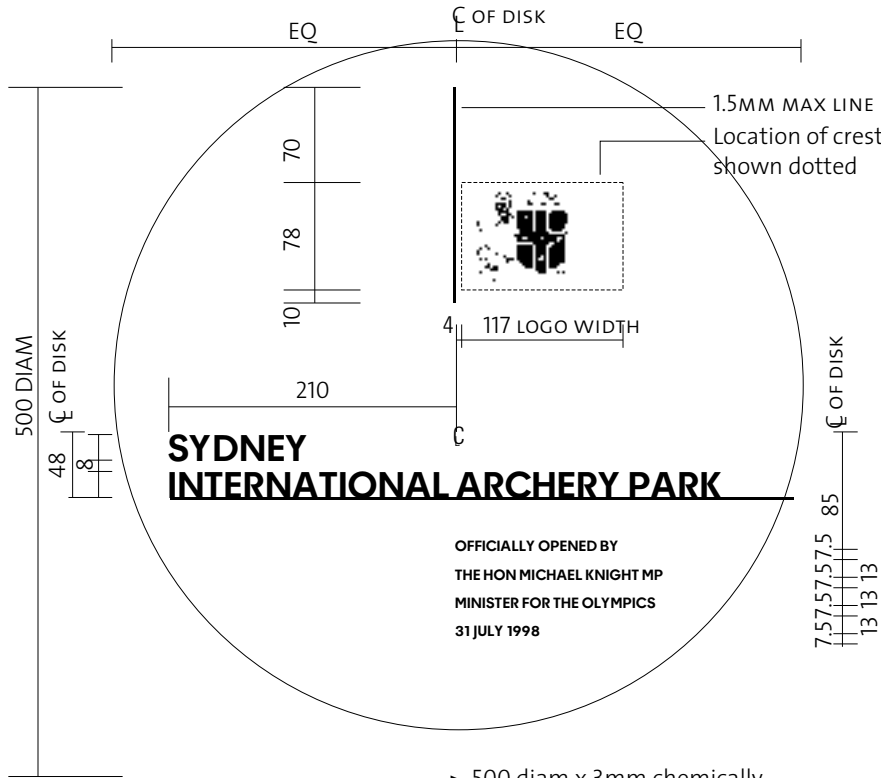

PLAN

- ▶ 500 diam x 3mm chemically bronzed brass plaque
- ▶ text, lines and crest to be engraved 1mm max in to brass
- ▶ horizontal and vertical line to be 1.5mm thick
- ▶ 2 pack laquer finish
- ▶ studs to rear of plaque (not visible on face) to be drilled and chemically glue fixed to masonry
- ▶ font is 19mm high and 11mm 'olympic 2000' available from SOPA in MAC and PC format

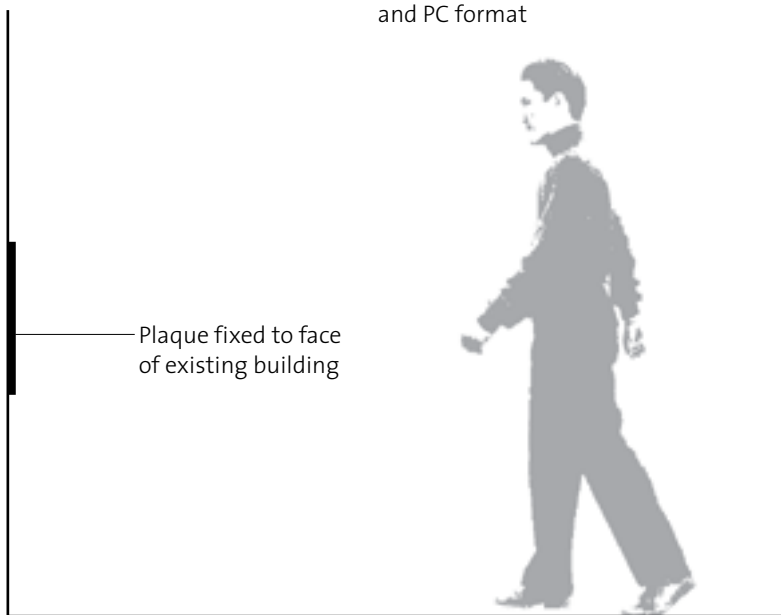

SIDE ELEVATION

**Principle**

Written information signage.

**Location**

As required.

REFER TO DETAILS APPENDICES A AND B

## Avenue Plinth with Commemorative Plaque

### Function

Plaque to commemorate streets and avenues attributed to sporting legends.

### Location

Fixed to concrete plinths appropriate location near street or avenue the plaque is dedicated to.

### Format

As per graphic representation shown.

### Specific Details

Typeface	S1
Materials and finishes	S6

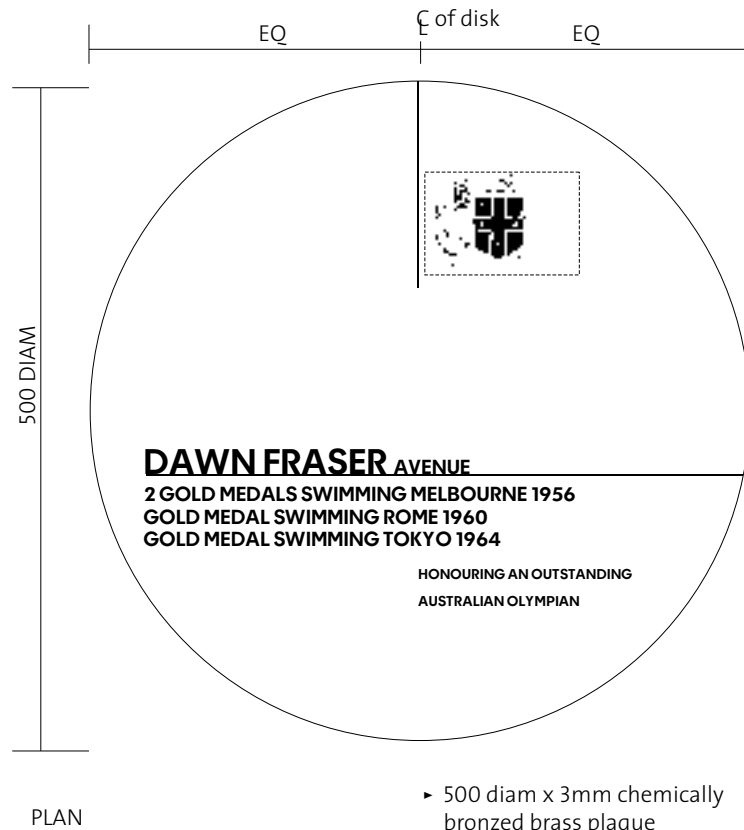

- ▶ 500 diam x 3mm chemically bronzed brass plaque
- ▶ text, lines and crest to be engraved 1mm max in to brass
- ▶ horizontal and vertical line to be 1.5mm thick
- ▶ 2 pack laquer finish
- ▶ studs to rear of plaque (not visible on face) to be drilled and chemically glue fixed to masonry
- ▶ font is 19mm and 11mm high 'olympic 2000' available from SOPA in MAC and PC format

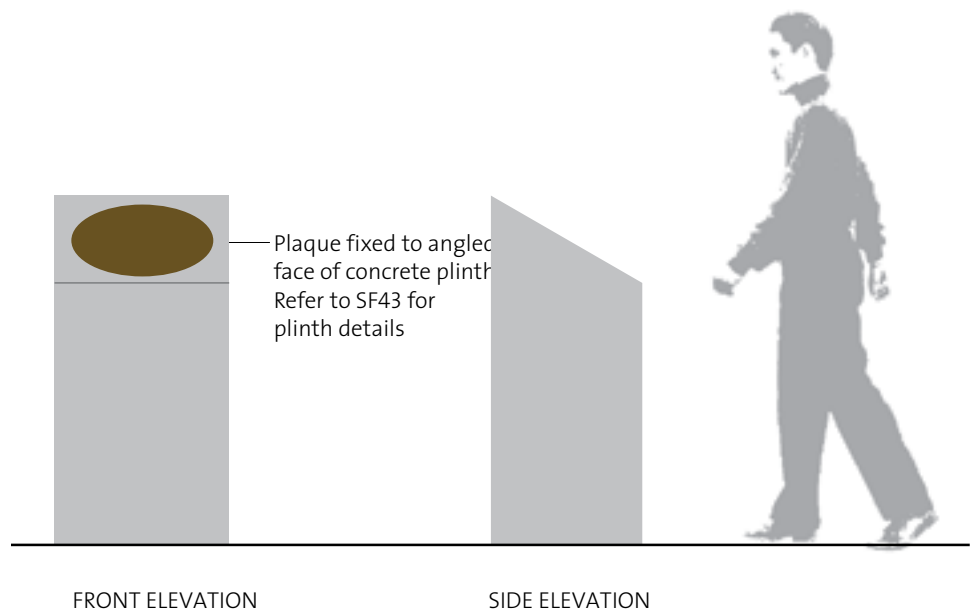

REFER TO DETAILS APPENDICES A AND B

# S47B

### Location

As required.

### Principle

Written information signage.